



COMMUNITY DEVELOPMENT BLOCK GRANT – DISASTER RECOVERY (CDBG-DR)

**AGREEMENT FOR
PV SYSTEMS AND WATER STORAGE SYSTEMS ACQUISITION AND INSTALLATION SERVICES
BETWEEN THE
PUERTO RICO DEPARTMENT OF HOUSING
AND
SYNERLUTION ENERGY, LLC**



THIS AGREEMENT FOR PV SYSTEMS AND WATER STORAGE SYSTEMS ACQUISITION AND INSTALLATION SERVICES, (hereinafter referred to as the "Agreement") is entered into in San Juan, Puerto Rico, this 15 of December, 2021, by and between the **PUERTO RICO DEPARTMENT OF HOUSING** (hereinafter, "PRDOH"), a public agency created under Law No. 97 of June 10, 1972, as amended, 3 L.P.R.A. § 441 *et seq.*, known as the Department of Housing Governing Act with principal offices at 606 Barbosa Avenue, San Juan, Puerto Rico, herein represented by William O. Rodríguez Rodríguez, attorney, of legal age, single, and resident of San Juan, Puerto Rico, in his capacity as Secretary; and **SYNERLUTION ENERGY, LLC**. (hereinafter, the "CONTRACTOR"), with principal offices in Rd #2 Km. 114.5 Marginal Bo. Guerrero, Isabela, Puerto Rico, 00662, herein represented by Irving Cruz Vadi, in his capacity as Managing Director, of legal age, married, and resident of Aguadilla, Puerto Rico duly authorized by Resolution by the CONTRACTOR.

WHEREAS, on September 2017, Hurricanes Irma and María made landfall in Puerto Rico causing catastrophic island wide damage, knocking out power, water, and telecommunications for the entire island and its island municipalities. Hurricane María caused major structure and infrastructure damage to family homes, businesses and government facilities triggering the displacement of thousands of residents of the Island from their homes and jobs.

W
WHEREAS, under the Continuing Appropriations Act, 2018 and Supplemental Appropriations for Disaster Relief Requirements Act, 2017, signed into law September 8, 2017 (Pub. L. 115-56), \$1.5 billion were allocated by the U.S. Department of Housing and Urban Development (HUD) for disaster recovery assistance to the Government of Puerto Rico under the CDBG-DR. These funds are intended to provide financial assistance to address unmet needs that arise and that are not covered by other sources of financial aid.

W
WHEREAS, on February 9, 2018, a Notice was published in the Federal Register, Vol. 83, No. 28 (83 FR 5844), that allocated \$1.5 billion for disaster recovery assistance to the Government of Puerto Rico.

WHEREAS, under the Bipartisan Budget Act of 2018, signed into law February 9, 2018 (Pub. L. 115-123), an additional \$8.22 billion were allocated by HUD for disaster recovery assistance to the Government of Puerto Rico under CDBG-DR.

WHEREAS, pursuant to a letter dated February 23, 2018 sent by the former Governor of Puerto Rico to the Secretary of HUD, the PRDOH is the governmental agency designated as grantee of the CDBG-DR funds allocated to the Government of Puerto Rico.

WHEREAS, on August 14, 2018, a Notice was published in the Federal Register Vol. 83, No. 157, (83 FR 40314) that made an additional allocation to Puerto Rico of \$8.22 billion for recovery. With these allocations of funding, the PRDOH aims to lead a transparent, comprehensive recovery to benefit the residents of Puerto Rico. PRDOH holds accountability and is committed to the responsible, efficient, and transparent administration of CDBG-DR grant funding.

WHEREAS, On September 20, 2018, the Governor of Puerto Rico and the Secretary of HUD signed the Grant Agreement.

WHEREAS, the PRDOH is interested in contracting a qualified vendor to assist PRDOH with Photovoltaic Systems (PV systems) and Water Storage System acquisition and installation Services for the Community Energy and Water Resilience Installation Program (CEWRI) under the CDBG-DR Program. These services are specifically intended for the equipment and installation of PV Systems and Water Storage Systems for homes that have been repaired or reconstructed under the Home Repair, Reconstruction, or Relocation Program (R3) and Social Interest Housing Program (SIH). The qualified vendor will support PRDOH's objectives of ensuring compliance with all CDBG-DR, HUD and applicable federal and local requirements, rules and regulations, as well as in PRDOH's objectives of the Action Plan, as amended, and adequately coordinating and monitoring all CDBG-DR related activities.

WHEREAS, on February 12, 2021, the PRDOH issued an invitation for Bids Number CDBG-DR IFB-2021-01 (IFB)" with CDBG-DR funds. The IFB was published in the *Registro Único de Subastas del Gobierno* (RUS by its Spanish acronym) and the CDBG-DR website. Through this procurement process, PRDOH was able to reach seventeen (17) qualified entities listed for their capacity and experience with federal grants to deliver qualified services.

WHEREAS, on April 9, 2021, the CONTRACTOR submitted a proposal (hereinafter referred to as the "Proposal"), which fully complied with the requirements set forth by the PRDOH.

7W
WHEREAS, Synerlution Energy, LLC Inc. was chosen to perform the required services at a reasonable proposed cost to assist PRDOH in the Puerto Rico's recovery efforts according to the award criteria established in the IFB.

WHEREAS, the PRDOH desires to enter into an agreement with **Synerlution Energy, LLC** to secure its services and accepts the CONTRACTOR's Proposal and costs, and the CONTRACTOR by its acceptance of the terms and conditions of this Agreement is ready, willing and able to provide the requested services contemplated under this Agreement.

Um
NOW THEREFORE, in consideration of the mutual promises and the terms and conditions set forth herein, the PRDOH and the CONTRACTOR agree as follows:

I. TYPE OF CONTRACT

Contract Type: This is a unit and system price contract. Under this Agreement, CONTRACTOR shall submit the official payment request to CEWRI Program Manager (PM) based on the Cost Form (**Attachment D**). Any and all changes and/or modifications to this Agreement shall be in writing and must be signed by both parties.

Attachments Incorporated: The following attachments are incorporated into this Agreement by reference and are hereby made part of this Agreement:

Attachment A	Notice of Award
Attachment B	Proposal
Attachment C	Scope of Work
Attachment D	Cost Form
Attachment E	Performance Requirements
Attachment F	Insurance Requirements (DV-OSPA-78-5)
Attachment G	HUD General Provisions

Attachment H	Contractor Certification Requirement
Attachment I	Labor Project Agreement
Attachment J	HUD Form 4010 (English and Spanish version)
Attachment K	SAM Wage Determination

All Attachments hereto are fully incorporated herewith such that the terms and conditions of the Attachments shall be as binding as any terms and conditions of this executed written Agreement. Should any inconsistency appear between the Attachments and this Agreement, the Agreement shall prevail.

II. TERM OF AGREEMENT

- 7W
- A. This Agreement shall be in effect and enforceable between the parties from the date of its execution. The Term of this Agreement will be for a performance period of **twenty-four (24) months**, ending on December 14, 2023
 - B. **Contract Extensions:** PRDOH may, at its sole discretion, extend the Agreement's term for an additional term of **twelve (12) months** or expressed in days, three hundred and sixty-five (365) days upon mutual written agreement of the parties.
 - C. The term of this Agreement shall not exceed the lifetime of the initial Grant Agreement between PRDOH and HUD, unless the term of the initial Grant Agreement is extended by HUD, in which case the Agreement shall not exceed said extended period.

III. SCOPE OF SERVICES

The CONTRACTOR will provide the services described in **Attachment C** of the Agreement. The parties agree that the CONTRACTOR shall furnish all permits, consents, licenses, equipment, software and supplies necessary to perform the Services, at CONTRACTOR's sole cost.

IV. COMPENSATION AND PAYMENT

- 8W
- A. The PRDOH agrees to pay the CONTRACTOR for allowable Services rendered under this Agreement in accordance with the rates and amounts described in **Attachment D** of this Agreement.

Upon completion of the installation, CONTRACTOR shall submit the official payment request to CEWRI PM with all applicable documentation, including warranty. Warranty documentation shall be submitted in duplicate (one for PM/PRDOH and one for homeowner/applicant) CONTRACTOR is responsible for delivering warranty information to the homeowner/applicant. If PRDOH determines that the submitted invoice and supporting documents are acceptable, then the invoice will be approved for payment.

- B. The PRDOH will pay the CONTRACTOR, for allowable services performed during the term of this Agreement, a maximum amount not to exceed **TWENTY SEVEN MILLION EIGHT HUNDRED TWENTY SEVEN THOUSAND AND THREE HUNDRED DOLLARS AND ZERO CENTS (\$27,827,300.00)**; Account Number R02H14HER-DOH-LM / R02H14HER-DOH-UN 6090-01-000.

- C. Such payment shall be compensation for all allowable services required, performed and accepted under this Agreement included in **Attachment D** and **Attachment E**.
- D. The PRDOH will pay the CONTRACTOR for all allowable services in four (4) stages divided as follows:
- o Stage 1 : \$8,000,000.00
 - o Stage 2 : \$8,000,000.00
 - o Stage 3 : \$8,000,000.00
 - o Stage 4 : \$3,827,300.00

Once a stage is finalized, for the CONTRACTOR to proceed with the following stage, the program must issue a Notice to Proceed when the requirements stated in the Agreement are fulfilled. If the CONTRACTOR does not comply with the performance expectations stated in the Agreement during the first (1st) stage, the PRDOH may terminate the Agreement.

- E. Any additional funds to complete the services requested by the PRDOH to the CONTRACTOR will be subject to evaluation before acceptance as well as funds availability and will require an amendment to this Agreement.
- F. The services rendered under the Agreement, shall be payable within thirty (30) business days from the date the invoice is received and approved by a PRDOH representative for payment. If PRDOH raises any objections, PRDOH will return the invoice for corrections and the CONTRACTOR shall modify the invoice and return it within five (5) business days. Once the CONTRACTOR returns the modified invoice, the PRDOH shall resume and conclude the payment process within the next thirty (30) business days.
- G. An authorized representative of the PRDOH will review each invoice and, if adequate, will approve and process its payment. Payments to the CONTRACTOR shall be made by electronic funds transfer (EFT). PRDOH reserves the right to conduct any audits it deems necessary. The CONTRACTOR agrees to cooperate fully with any such audit or audits.
- H. While providing the services under this Agreement, the CONTRACTOR must adhere to applicable requirements of the CDBG-DR grant. If the CONTRACTOR performs ineligible activities under the CDBG-DR grant or program, the CONTRACTOR cannot include them in the invoice for payment to the CONTRACTOR.
- I. CONTRACTOR shall be liable to the PRDOH for any costs disallowed pursuant to financial and/or compliance audit(s) of funds received under this Agreement. CONTRACTOR shall reimburse such disallowed costs from funds other than those CONTRACTOR received under this Agreement.
- J. The CONTRACTOR acknowledges and agrees to repay any CDBG-DR funds used for ineligible costs.
- K. Extended overhead costs is an Ineligible cost under this Agreement and shall not be reimbursable.

- L. In order for the CONTRACTOR to receive payment for any work performed hereunder, the following certification must be included in each application for payment or invoice submitted to the PRDOH for payment:

“Under penalty of absolute nullity, I hereby certify that no public servant of the government entity is a party to or has an interest of any kind in the profits or benefits to be obtained under the contract which is the basis of this invoice, and should he be a party to, or have an interest in, the profits or benefits to be obtained under the contract, a waiver has been previously issued. The only consideration to provide the contracted goods or services under the contract is the payment agreed upon with the authorized representative of the government entity. The amount that appears in the invoice is fair and correct. The work has been performed, the goods have been delivered, and the services have been rendered, and no payment has been received therefor.”

V. REIMBURSABLE EXPENSES

The PRDOH will not reimburse any costs incurred by the CONTRACTOR not included in the approved Proposal or in an executed written amendment.

VI. ADDITIONAL SERVICES

Should additional services be needed by the PRDOH, such additional services shall be agreed upon by the parties in a written document signed by both parties, prior to the issuance of a notice to proceed with the performance of such additional services.

VII. OWNERSHIP AND USE OF DOCUMENTS

- A. With the exception of the CONTRACTOR's working papers, the CONTRACTOR acknowledges the PRDOH's ownership of all information, drafts, documents, reports, papers, and other materials developed and prepared by the CONTRACTOR, its agents or representatives, for purposes of performing key obligations hereunder. In the event of any termination, the CONTRACTOR shall deliver such information, drafts, reports, papers and other materials to the PRDOH, in document form or as computer program data, and the CONTRACTOR recognizes the PRDOH's right to request such documentation or computer program data. If the CONTRACTOR fails to deliver said information, the PRDOH may seek a judicial order to enforce its rights.
- B. Proof of expenditures incurred by the CONTRACTOR on behalf of PRDOH shall be made available to PRDOH. The CONTRACTOR agrees to maintain accurate records and files of all contract documents, correspondence, book estimates, bills, and other information related to the CONTRACTOR account. These documents shall be open for the PRDOH examination at all reasonable times during the term of this Agreement, and up to **five (5) years** from closeout of the grant to the state, or the period required by other local applicable laws and regulations.

VIII. DOCUMENTATION AND RECORDERKEEPING

- A. **Records to be Maintained:** The CONTRACTOR shall maintain records of the state and units of general local government, including supporting documentation, which shall be retained for the greater of **five (5) years** from closeout of the grant to the state, or the period required by other local applicable laws and regulations. Such records

include but are not limited to: Records providing a full description of each activity undertaken; Records demonstrating that each activity undertaken meets one of the National Objectives of the CDBG-DR program; Records required to determine the eligibility of activities; Records required to document the acquisition, improvement, use or disposition of real property acquired or improved with CDBG-DR assistance; Records documenting compliance with the fair housing and equal opportunity requirements of the CDBG-DR program regulations; Financial records as required by 24 C.F.R. § 570.502, and 2 C.F.R. part 200, including records necessary to demonstrate compliance with all applicable procurement requirements; and other records necessary to document compliance with this agreement, any other applicable Federal statutes and regulations, and the terms and conditions of PRDOH's Federal award.

- rw*
- B. Access to Records:** The CONTRACTOR shall permit the PRDOH and auditors to have access to the CONTRACTOR's records and financial statements as necessary for the PRDOH to meet its audit requirements under the Federal award.
 - C. Record Retention and Transmission of Records to the PRDOH:** Prior to close out of this Agreement, the CONTRACTOR must transmit to the PRDOH records sufficient for the PRDOH to demonstrate that all costs under this Agreement met the requirements of the Federal award.
 - D. CONTRACTOR's Data and Privileged Information:** The CONTRACTOR is required to maintain confidential data demonstrating client eligibility for activities provided under this Agreement. Such data may include, but not be limited to, client name, address, income level or other basis for determining eligibility, and description of activities provided.
 - E. PII Policy:** The CONTRACTOR must comply with the PRDOH CDBG-DR Personal Identifiable Information Policy, as found in the CDBG-DR Website (www.cdbg-dr.pr.gov), which is herein included and made integral part of this Agreement, as it may be updated from time to time.

IX. ACCESS TO RECORDS

- rw*
- A.** The CONTRACTOR agrees to provide the Government of Puerto Rico, PRDOH, HUD's Secretary, the Comptroller General of the United States, or any of their authorized representative's access to any books, documents, papers, and records of the CONTRACTOR which are directly pertinent to this Agreement for the purposes of making audits, examinations, excerpts, and transcriptions.
 - B.** The CONTRACTOR agrees to permit any of the foregoing parties to reproduce by any means whatsoever or to copy excerpts and transcriptions as reasonably needed.

X. NON-DISCLOSURE AND CONFIDENTIALITY

- A. Confidential Information; Definition:** The term Confidential Information as used throughout this Section, means any information concerning PRDOH operations and that of its CONTRACTOR (e.g., the projects, computer processing systems, object and source codes and other PRDOH business and financial affairs). The term Confidential Information shall also deem to include all notes, analysis, compilation, studies and interpretation or other documents prepared by CONTRACTOR, its agents or representatives, in connection with PRDOH operations.

- B. Non-Disclosure:** CONTRACTOR agrees to take all reasonable steps or measures to keep confidential all Confidential Information and will not, at any time, present or future, without PRDOH express written authorization, signed by the Secretary of the PRDOH, use or sell, market or disclose any Confidential Information to any third party, contractor, corporation, or association for any purpose whatsoever. CONTRACTOR further agrees that, except as they relate to the normal course of the service, the CONTRACTOR will not make copies of the Confidential Information except upon PRDOH express written authorization, signed by an authorized representative of PRDOH, and will not remove any copy or sample of Confidential Information without prior written authorization from PRDOH. CONTRACTOR retains the right to control its work papers subject to these confidentiality provisions.
- C. Return Documents:** Upon receipt of written request from the PRDOH, CONTRACTOR will return to PRDOH all copies or samples of Confidential Information which, at the time of the notice are in CONTRACTOR's or its agent's possession. CONTRACTOR reserves the right to retain a set of its work papers.
- D. Equitable Relief:** The CONTRACTOR acknowledges and agrees that a breach of the provision of subparagraph B and C of this Section will cause PRDOH to suffer irreparable damage that could not be remedied or compensated adequately only by mere monetary retribution. The CONTRACTOR further agrees that money damages may not be a sufficient remedy for any breach of this Section. Accordingly, the CONTRACTOR agrees that PRDOH shall have the right to seek injunctive relief and the specific performance of the provisions of this Section to enjoin a breach or attempted breach of the provision hereof, such right being in addition to any and all other rights and remedies that are available to PRDOH by law, equity, or otherwise.

XI. PERFORMANCE WARRANTY

- (a) CONTRACTOR warrants that it will perform all work and provide all Deliverables under this Contract in a manner consistent with the degree of care and skill ordinarily exercised by members of the same profession currently practicing under similar circumstances.
- (b) CONTRACTOR warrants that all Deliverables it completes under this Contract shall: meet or exceed the standards of CONTRACTOR's trade, profession, or industry; meet or exceed the specifications set forth in the Attachments to this Agreement; and be fit for ordinary use, of good quality, and with no material defects.
- (c) If CONTRACTOR submits Deliverables that do not meet specifications, fails to complete Deliverables timely, or fails to perform its obligation under this Contract, PRDOH may require CONTRACTOR, at its sole expense, to:
1. repair or replace Deliverables that do not meet specifications;
 2. refund payment for Deliverables that do not meet specifications and accept the return of such Deliverables;
 3. pay liquidated damages for any past due Deliverable; and
 4. take necessary action to ensure that future performance and Deliverables meet specifications and conform to the Contract.

XII. TERMINATION

- A. Termination for Cause or Default:** The PRDOH may terminate this Agreement, in whole or in part, because of CONTRACTOR's failure to fulfill any of its obligations. The PRDOH shall terminate this Agreement by delivering to the CONTRACTOR a **thirty (30) calendar day** notice of termination specifying the extent to which the performance of the service under this Agreement is terminated, the reason therefor and the

effective date of termination. CONTRACTOR shall, upon written notice, be provided a **ten (10) calendar day** opportunity to cure the alleged defect that resulted in the perceived default. If the defect is not cured within that period of time, CONTRACTOR shall immediately discontinue all such services being terminated and deliver to the PRDOH all information, notes, drafts, documents, analysis, reports, compilations, studies and other materials accumulated or generated in performing the services contemplated in this Agreement, whether completed or in process. Notwithstanding the above, the CONTRACTOR shall not be relieved of liability to the PRDOH for damage sustained to PRDOH CDBG-DR Program by virtue of any breach of the Agreement by the CONTRACTOR. The PRDOH may withhold any payments to the CONTRACTOR, for the purpose of off-set or partial payment, as the case may be, of amounts owed to the PRDOH by the CONTRACTOR. PRDOH shall make payment, in accordance with the terms of this Agreement, of any amounts due to CONTRACTOR for allowable services rendered prior to the termination notice.

7/10

B. Termination for Convenience: The PRDOH may terminate this Agreement, in whole or in part, whenever the PRDOH determines that such termination is necessary or convenient to the Agency. The PRDOH will terminate this Agreement by delivering to the CONTRACTOR a **thirty (30) calendar day** notice of termination specifying the extent to which the performance of the work under this Agreement is terminated, and the effective date of termination. Upon receipt of such notice, the CONTRACTOR shall immediately discontinue all services affected and deliver to the PRDOH all information, studies and other materials property of the PRDOH. In the event of a termination by Notice, the PRDOH shall be liable only for payment of services rendered up to and including the effective date of termination. PRDOH shall make payment, in accordance with the terms of this Agreement, of any amounts due to CONTRACTOR for allowable services rendered prior to the termination notice.

MM

C. Termination by Unilateral Abandonment: The PRDOH will consider this Agreement immediately terminated, in the event that the CONTRACTOR unilaterally and without prior notice, chooses to abandon (in any shape, form or fashion) cease and desist in the specific performance of its general and particular duties and responsibilities as agreed in this Agreement. Upon the knowledge of such event, the PRDOH will not be held liable and will immediately, automatically and retroactively deduct from any future reimbursement, all funds from the day such unilateral abandonment took place. The PRDOH will not be compelled to continue the performance of the Agreement, should the CONTRACTOR breach the Agreement by unilateral abandonment. For the purposes of this Section, Abandonment shall mean that CONTRACTOR voluntarily and intentionally disavows its contractual duties in a manner that is overt and without question a relinquishment of said contractual duties.

D. Unilateral Termination: The PRDOH may terminate this Agreement, in whole or in part, at PRDOH's sole discretion, with or without cause, at any time. The PRDOH will terminate this Agreement by delivering to the CONTRACTOR a **thirty (30) calendar day** notice of termination specifying the extent to which the performance of the work under this Agreement is terminated, and the effective date of termination. Upon receipt of such notice, the CONTRACTOR shall immediately discontinue all services affected and deliver to the PRDOH all information, studies and other materials property of the PRDOH. In the event of a termination by Notice, the PRDOH shall be liable only for payment of services rendered up to and including the effective date of termination.

E. Suspension: The PRDOH may suspend this Agreement in whole or in part at any time for the PRDOH's convenience. The PRDOH shall give the CONTRACTOR **five (5)**

business days' written notice of such suspension. Upon receipt of said notice the CONTRACTOR shall immediately discontinue all Services affected.

F. Immediate Termination: In the event the CONTRACTOR is subjected to a criminal or civil action, suit, proceeding, inquiry or court of applicable jurisdiction, or any governmental agency, or the CONTRACTOR shall be subject to an order, judgment, or opinion, issued by any federal or local authority, a court of applicable jurisdiction, or any governmental agency, in connection with the execution, delivery, and performance by the CONTRACTOR of this Agreement or the CONTRACTOR of this Agreement has been noncompliant, breach, inaccuracy of any representation, warranties, covenants, or the certifications provided herein, whether the noncompliance, breach or inaccuracy takes place before or after the execution of this Agreement, the PRDOH shall have the right to the immediate termination of this Agreement notwithstanding, any provisions to the contrary herein. This Section will apply in the event of any judgment that may obligate the PRDOH to terminate the Agreement pursuant to Act Number 2 of January 2, 2018, as amended, known as the Anti-Corruption Code for the New Puerto Rico.

G. Period of Transition: Upon termination of this Agreement, and for **ninety (90) consecutive calendar days** thereafter (the Transition Period), CONTRACTOR agrees to make himself available to assist the PRDOH with the transition of services assigned to CONTRACTOR by the PRDOH. CONTRACTOR shall provide to the PRDOH the assistance reasonably requested to facilitate the orderly transfer of responsibility for performance of the Services to the PRDOH or a third party designated by the PRDOH. PRDOH reserves the right to provide for the execution of a Transition Services Agreement for the Transition Period. In such instance, the CONTRACTOR will be paid at a reasonable, agreed upon, hourly rate for any work performed for the PRDOH during the Transition Period. Moreover, during that Transition Period, all finished or unfinished records (files, data, work product) connected with this Agreement will be turned over to PRDOH.

XIII. PENALTIES AND LIQUIDATED DAMAGES

A. Penalties

1. In the event the CONTRACTOR is determined to have engaged in any proscribed conduct or otherwise is in default as to any applicable term, condition, or requirement of this Agreement, at any time following the Effective Date of the Agreement, the CONTRACTOR agrees that, PRDOH may impose sanctions against the CONTRACTOR for any default in accordance with **Attachment C** and **Attachment E** and this Section. Refer to all required provisions set forth at 2 C.F.R. § 200.326 and 24 C.F.R. § 570.489(g), and the CDBG-DR Procurement Manual and Contract Requirements, Art. XII, Section 2(a.), as found in the CDBG-DR Website (www.cdbg-dr.pr.gov) which is herein included and made integral part of this Agreement, as it may be updated from time to time.
2. If the CONTRACTOR fails to comply with federal statutes, regulations or the terms and conditions of the Agreement, PRDOH may take one or more of the following actions:
 - i. Temporarily withhold cash payments pending correction of the deficiency by the CONTRACTOR.
 - ii. Disallow all or part of the cost of the activity or action not in compliance.

- iii. Initiate suspension or debarment proceedings as authorized under 2 C.F.R. part 180.
- iv. Withhold further Federal awards for the project or program.
- v. Take other remedies that may be legally available.

B. Liquidated damages

The CONTRACTOR shall pay to PRDOH, as liquidated damages, as related to their timeframes of performance. The PRDOH and the CONTRACTOR will agree on the timetable for the deliverable of each task. The CONTRACTOR shall pay to PRDOH, as liquidated damages, the amount established below for each calendar day that a deliverable required is late until deemed in compliance subject to a maximum of amount as established below.

Type of Work	Liquidated Damages for each calendar day	Maximum Amount of Liquidated Damages per occurrence, deliverable and task.
PV System Equipment, Installation, and related services	\$500.00	\$5,000.00
WSS Equipment, Installation, and related services	\$100.00	\$1,000.00

Said sum, in view of the difficulty of accurately ascertaining the loss which PRDOH will suffer by reason of delay in the completion of the Work hereunder, is hereby fixed and agreed as the liquidated damages that PRDOH will suffer by reason of such delay. Liquidated damages received hereunder are not intended to be nor shall they be treated as either a partial or full waiver or discharge of the PRDOH's right to indemnification, or the CONTRACTOR's obligation to indemnify the PRDOH pursuant to this Contract, or to any other remedy provided for in this Contract or by Law. Liquidated damages may be assessed at the sole discretion of PRDOH. For the purpose of applying and calculating such liquidated damages, a grace period of **ten (10) business days** shall be observed. The PRDOH may deduct and retain out of the monies which may become due hereunder, the amount of any such liquidated damages; and in case the amount which may become due hereunder shall be less than the amount of liquidated damages due to the PRDOH per the formula above, the CONTRACTOR shall be liable to pay the difference.

XIV. LIABILITY

In no event, the PRDOH shall be liable for any indirect, incidental, special or consequential damages, or damages for loss of profits, revenue, data or use, incurred by either party or any third party, whether in an action in contract or tort, even if the other party or any person has been advised of the possibility of such damages. Third parties operating under this program, with their agency, will have their own general civil and criminal liability imposed by law towards the PRDOH, the CONTRACTOR and any citizen.

The CONTRACTOR shall carry the insurances as are required by law (if applicable), as set forth below. The CONTRACTOR shall furnish PRDOH certificates of insurance.

XV. INSURANCE

A. Required Coverage

The CONTRACTOR shall keep in force and effect for the period beginning from the execution of the Agreement and ending at the completion of all services to be provided hereunder, insurance policies in compliance with the PRDOH's requirements as set forth

in OSPA-78-5, attached hereto and made an integral part hereof as **Attachment F**. The CONTRACTOR shall meet all other insurance requirements as may be imposed by PRDOH from time to time.

Upon the execution of this Agreement, the CONTRACTOR shall furnish PRDOH with original and two (2) certified copies of the insurance policies described in **Attachment F** and any other evidence PRDOH may request as to the policies' full force and effect.

Any deductible amount, under any of the policies, will be assumed in whole by the CONTRACTOR for any and all losses, claims, expenses, suits, damages, costs, demands or liabilities, joint and several of whatever kind and nature arising from the Agreement resulting from this solicitation by and between the CONTRACTOR and PRDOH.

The PRDOH shall not be held responsible under any circumstances for payments of any nature regarding deductibles of any Commercial Liability Policies for the aforementioned Agreement.

B. Endorsements

Each insurance policy maintained by the CONTRACTOR must be endorsed as follows:

1. PRDOH, Government of Puerto Rico, HUD and its officers, agents and employees are named as additional insured (except Worker's Compensation) but only with respect to liability arising out of tasks performed for such insured by or on behalf of the named insured.
2. To provide waiver of subrogation coverage for all insurance policies provided or herein in favor of PRDOH and its respective officers, agents and employees.
3. The insurer shall be required to give PRDOH written notice at least **thirty (30) days** in advance of any cancellation in any such policies.

The CONTRACTOR shall furnish to PRDOH, prior to commencement of the work, certificates of insurance from insurers with a rating by the A.M. Best Co. of B+ and five (5) or over on all policies, reflecting policies in force, and shall also provide certificates evidencing all renewals of such policies. Insurers shall retain an A.M. Best Co. rating of B+ and five (5) or over on all policies throughout the term of this Agreement and all policy periods required herein. The insurance company must be authorized to do business in Puerto Rico and be in good standing.

C. Related Requirements

The CONTRACTOR shall furnish original Certificates of Insurance evidencing the required coverage to be in force on the Effective Date of Agreement. In the case of Payment and Performance Bond, Certificate of Authority, Power of Attorney and Power of Attorney License issued by the Commissioner of Insurance shall be furnished. THE REQUIRED DOCUMENTATION MUST BE RECEIVED PRIOR TO THE CONTRATOR COMMENCING WORK. NO CONTRACTOR OR ITS AUTHORIZED REPRESENTATIVES ARE TO BEGIN THEIR RESPONSIBILITIES UNDER THE AGREEMENT PRIOR TO FULL COMPLIANCE WITH THIS REQUIREMENT AND NOTIFICATION FROM PRDOH TO PROCEED.

Renewal Certificates of Insurance or such similar evidence is to be received by the Contract Administration of the Legal Division and/or the Finance area of the CDBG-DR program prior to expiration of insurance coverage. At PRDOH's option, non-compliance

will result in one or more of the following actions: (1) The PRDOH will purchase insurance on behalf of the CONTRACTOR and will charge back all cost to the CONTRACTOR; (2) all payments due the CONTRACTOR will be held until the CONTRACTOR has complied with the Agreement; and/or (3) The CONTRACTOR will be assessed **Five Thousand Dollars (\$5,000.00) for every day of non-compliance.**

The receipt of any certificate does not constitute agreement by PRDOH that the insurance requirements in the Agreement have been fully met or that the insurance policies indicated on the certificate are in compliance with the requirements of the Agreement. The insurance policies shall provide for **thirty (30) days** written notice to be given to PRDOH in the event coverage is substantially changed, cancelled or non-renewed.

The CONTRACTOR shall require all subcontractors or consultants to carry the insurance required herein or the CONTRACTOR, may provide the coverage for any or all of its subcontractors and if so, the evidence of insurance submitted shall so stipulate and adhere to the same requirements and conditions as outlined above.

The CONTRACTOR expressly understands and agrees that whenever the CONTRACTOR is covered by other primary, excess, or excess contingent insurance that, any insurance or self-insurance program maintained by PRDOH shall apply in excess of and will not contribute with insurance provided by the CONTRACTOR under this Agreement.

rw

D. Payment and Performance Bonds

The CONTRACTOR will obtain, and at all times during the course of the installation and operation until the work is completed under the contract, or subcontract as the case may be, cause to maintain a payment and performance bond in such amounts required by the PRDOH and/or as established in the contract. The work shall be considered completed when the warranty period expires or after one year has elapsed from the final inspection and PRDOH acceptance, and the CONTRACTOR has delivered a final, unconditional lien waiver with respect thereto.

rw

In the instance the amount of the payment and performance bond, as required by the PRDOH, is less than the full amount of the award (contract), the CONTRACTOR shall only provide services (Task Orders) up to the bond amount. If the bonding capacity of the CONTRACTOR increases during the existence of the contract, the CONTRACTOR shall provide such evidence (bond) to the PRDOH, and the PRDOH will increase the work capacity (Task Orders) accordingly but never exceeding the bond amount.

The PRDOH shall provide the Contractors with new Task Orders, when the previous ones are considered completed. If by any reason the CONTRACTOR has Task Orders in excess of the Payment and Performance Bond, the CONTRACTOR shall notify the PRDOH in **less than ten (10) calendar days** or prior to the commencement of any work. Failure to notify the PRDOH may result in the payment of damages and liabilities arising under such Task Orders, and the Contractor will be at risk of not receiving payments for the works done in excess of the Payment and Performance Bond.

In any case that the CONTRACTOR works in excess of the Payment and Performance Bond, the CONTRACTOR agrees to hold the Government of Puerto Rico, the PRDOH, and/or HUD, harmless from any and all claims, loss, liabilities and costs, including attorney's fees, as a result of the work done in excess of the Payment and Performance Bond, including any events incidental to said work. If the Government of Puerto Rico, the

PRDOH, and/or HUD incur any of these types of expenses, the CONTRACTOR agrees to reimburse the Government of Puerto Rico, the PRDOH, and/or HUD.

XVI. HOLD HARMLESS

The CONTRACTOR and its affiliates, its successors and assignees will indemnify the PRDOH from any damages and/or losses arising out of any breach of this Agreement by the CONTRACTOR or against personal injuries or property damage resulting from any act of negligence or omission by the CONTRACTOR and its affiliates in connection with this Agreement.

XVII. FORCE MAJEURE

In the event of a fire, flood, earthquake, natural disaster, hurricane, riot, act of governmental authority in its sovereign capacity, pandemic officially declared by the Government of Puerto Rico, strike, labor dispute or unrest, embargo, war, insurrection or civil unrest, any *Force Majeure* including inclement weather, herein collectively referred to as *Force Majeure* during the term of this Agreement, neither the PRDOH nor the CONTRACTOR shall be liable to the other party for nonperformance during the conditions created by such event.

rw
The CONTRACTOR shall notify, as soon as possible, the PRDOH of the occurrence of the *Force Majeure* event and describe in reasonable detail, the nature of the *Force Majeure* event.

XVIII. CONFLICTS OF INTEREST

The CONTRACTOR shall comply with the ethics requirements set forth herein and warrant that to the best of its knowledge and belief and except as otherwise disclosed, it does not have any organizational conflict of interest which is defined as a situation in which the nature of the work under a PRDOH contract and CONTRACTOR'S organizational, financial, contractual or other interest are such that:

- a) Award of the Agreement may result in an unfair competitive advantage; or
- b) The CONTRACTOR's objectivity in performing the contract work may be impaired.

rw
The CONTRACTOR agrees that if after award he or she discovers an organizational conflict of interest with respect to this Agreement, it shall make an immediate (within the next **seventy-two (72) hours**) and full disclosure in writing to the Contracting Officer, which shall include a description of the action, which the CONTRACTOR has taken or intends to take to eliminate or neutralize the conflict. The CONTRACTOR will disclose the details of any existing or future contract to provide services to third parties participating or for the purpose to participate in disaster recovery programs or projects in Puerto Rico. The PRDOH may, however, terminate the Agreement for the convenience of PRDOH if it would be in its best interest.

In the event the CONTRACTOR was aware of an organizational conflict of interest before the award of this Agreement and did not disclose the conflict to the Contracting Officer, the PRDOH may terminate the Agreement for default.

The provisions of this clause shall be included in all subcontracts and/or consulting agreements wherein the work to be performed is similar to the services provided by the

CONTRACTOR. The CONTRACTOR shall include in such subcontracts and consulting agreements any necessary provision to eliminate or neutralize conflicts of interest.

XIX. INDEPENDENT CONTRACTOR

The relationship of the CONTRACTOR to PRDOH shall be that of an independent CONTRACTOR rendering professional services. Neither the CONTRACTOR nor any personnel of the CONTRACTOR shall have any authority to execute contracts or make commitments on behalf of PRDOH. Nothing contained herein shall be deemed to create the relationship of employer/employee, principal/agent, joint venture or partner between the CONTRACTOR and PRDOH. Further, the CONTRACTOR recognizes that in view of its status as an independent CONTRACTOR, neither it nor its employees or subcontractors will be entitled to participate in or receive any fringe benefits normally granted to PRDOH employees under such programs, including, but not limited to, worker's compensation, voluntary disability, travel accident insurance, medical/dental insurance, life insurance, long-term disability, holiday pay, sick pay, salary continuation pay, leaves of absence (paid or unpaid), pension plan and savings plan.

7W
The CONTRACTOR shall have exclusive control over its employees and subcontractors (and the CONTRACTOR's employees and subcontractors are herein, collectively, referred to as the "CONTRACTOR Personnel"), its labor and employee relations and its policies relating to wages, hours, working conditions and other employment conditions. The CONTRACTOR has the exclusive right to hire, transfer, suspend, lay off, recall, promote, discipline, discharge and adjust grievances with its CONTRACTOR Personnel. The CONTRACTOR is solely responsible for all salaries and other compensation of its CONTRACTOR Personnel who provide Services.

UN
The CONTRACTOR is solely responsible for making all deductions and withholdings from its employees' salaries and other compensation and paying all contributions, taxes and assessments, including union payments. The CONTRACTOR shall be responsible for and shall defend, indemnify and hold harmless PRDOH, and its agents, officers, directors, employees, representatives, CONTRACTOR's, successors and assigns against all costs, expenses and liabilities, including without limitation reasonably prudent attorneys' fees relative to the situation, in connection with the CONTRACTOR's employment and/or hiring of any CONTRACTOR Personnel providing any of the Services, including without limitation: (i) payment when due of wages and benefits, (ii) withholding of all payroll taxes, including but not limited to, unemployment insurance, workers' compensation, FICA and FUTA, (iii) compliance with the Immigration Reform Control Act, and (iv) compliance with any other applicable laws relating to employment of any CONTRACTOR Personnel of, and/or hiring by, CONTRACTOR in connection with the Services.

XX. NOTICES

All notices required or permitted to be given under the Agreement shall be in writing, and shall be deemed given when delivered by hand or sent by registered or certified mail, return receipt requested, to the address as follows:

To: PRDOH

William O. Rodríguez Rodríguez, Esq.
Secretary
Puerto Rico Department of Housing
606 Barbosa Ave.
Juan C. Cordero Dávila Bldg.
San Juan, PR 00918

To: CONTRACTOR

Irving Cruz Vadi
Managing Director
Synerlution Energy, LLC
2221 Militar Ave. Suite 103
Isabela, Puerto Rico, 00662

XXI. THIRD PARTIES

Nothing contained in this Agreement shall create a contractual relationship with, or a cause of action of a third party against either the PRDOH or the CONTRACTOR.

XXII. SUBCONTRACTS

A. General: All subcontracts shall contain the applicable provisions described in **Attachment G** (HUD General Provisions), as well as applicable provisions set forth in 2 C.F.R. § 200.101. The PRDOH shall review subcontracts as part of the compliance, monitoring, and oversight process performed by PRDOH or upon request.

B. Specific Requirements: All subcontracts shall contain provisions specifying:

- i. That the work performed by the subcontractor be in accordance with the applicable terms of this Agreement between the PRDOH and CONTRACTOR;
- ii. That nothing contained in such subcontract agreement shall impair the rights of the PRDOH;
- iii. That nothing contained herein, or under this Agreement will create any contractual relation between the subcontractor and the PRDOH;
- iv. That the subcontractor specifically agrees to be bound by the confidentiality provision regarding Personal Identifiable Information set forth in this Agreement;
- v. That CONTRACTOR will be responsible for ensuring all subcontract work is performed consistent with federal and state regulations and/or policies to be eligible for reimbursement of the approved work; and
- vi. All Federal flow down provisions are included in the subcontract agreement per Federal guidelines.

C. Monitoring: CONTRACTOR shall diligently monitor all subcontracted services. If CONTRACTOR discovers any areas of noncompliance, CONTRACTOR shall provide the PRDOH summarized written reports supported with documented evidence of corrective action.

D. Content: CONTRACTOR shall cause all the applicable provisions of this Agreement to be included in, and made a part of, any subcontract executed in the performance of this Agreement.

E. Notification: CONTRACTOR shall notify and provide a copy of any and all subcontracts related to this Agreement and CDBG-DR funds to the Contract Administration Area of the PRDOH CDBG-DR Legal Division within **three (3) business days** of its execution.

XXIII. CERTIFICATION OF COMPLIANCE WITH LEGAL REQUIREMENTS

Given that the Agreement involves funds for which HUD is the oversight agency, the CONTRACTOR agrees to carry out its obligations under this Agreement in compliance

with all the requirements described in **Attachment G** (HUD General Provisions), **Attachment H** (Contractor Certification Requirement) and the following provisions:

A. Compliance with Executive Order No. OE-2021-023: The CONTRACTOR agrees to faithfully comply with the provisions of the Executive Order No. OE-2021-023 of March 18, 2021 (OE-2021-023), the Labor Project Agreement signed by the PRDOH and the Contractor (**Attachment I**).

The CONTRACTOR will provide a minimum salary of ten dollars and ninety five cents (\$10.95) per hour to all construction worker, for the work performed within the "Construction Project", as defined in the OE-2021-023.

The CONTRACTOR commits to acquire and use cement produced in Puerto Rico in compliance with Act No. 109 of July 12, 1985 for the completion of the "Construction Project". The CONTRACTOR acknowledges that this is an essential condition of this Agreement whose breach by itself, or by any subcontractor, will release PRDOH from disburse funds for any part or section of the "Construction Project" completed in non-compliance with OE-2021-023. In addition, the CONTRACTOR recognizes that non-compliance with this clause could lead to cancellation, without more, of this Agreement.

7w
The CONTRACTOR shall include in any awarded contract to perform the work on behalf of the PRDOH, a clause in which obligate the subcontractor to comply with all provisions of OE-2021-023 (including the provisions concerning the acquisition of cement produced in Puerto Rico and the minimum compensation for workers who work within the "Construction Project"), the Labor Project Agreement signed between the PRDOH and the Contractor, as well as any other document issued pursuant to OE-2021-023.

Similarly, the clause to be included by the CONTRACTOR must provide for any subcontractor to include a similar compliance clause in any subcontract that provides for the release of its obligation before the CONTRACTOR.

W
B. Compliance with Act No. 173. The CONTRACTOR hereby certifies that in signing this Agreement it is in compliance with Act No. 173 of August 12, 1988, as amended, known as the "Board of Examiners of Engineers, Architects, Surveyors, and Landscape Architects of Puerto Rico Act", 20 L.P.R.A. §§ 711-711z to exercise the profession of engineering, architecture, surveying or landscaping architecture in Puerto Rico, is registered in the official Register of the Board, and is an active member of the College of Engineers and Surveyors of Puerto Rico or the College of Architects and Landscape Architects of Puerto Rico, as applicable.

C. Compliance with Executive Order 24: Pursuant to Executive Order 24 of June 18, 1991, the CONTRACTOR certifies and guarantees that at the signing of this Agreement it has filed all the necessary and required income tax returns to the Government of Puerto Rico for the last **five (5) years**. The CONTRACTOR further certifies that it has complied and is current with the payment of any and all income taxes that are, or were due, to the Government of Puerto Rico. The CONTRACTOR shall hand out, to the satisfaction of the PRDOH and whenever requested by the PRDOH during the term of this Agreement, the necessary documentation to support its compliance of this clause. The CONTRACTOR will be given a specific amount of time by the PRDOH to produce said documents. During the term of this Agreement, the CONTRACTOR agrees to pay and/or to remain current with any repayment plan agreed to by the CONTRACTOR with the Government of Puerto Rico.

D. Compliance with Executive Order 52: Pursuant to Executive Order 52 of August 28, 1992, amending EO-1991-24, the CONTRACTOR certifies and warrants that it has made all payments required for unemployment benefits, workmen's compensation and social security for chauffeurs, whichever is applicable, or that in lieu thereof, has subscribed a payment plan in connection with any such unpaid items and is in full compliance with the terms thereof. The CONTRACTOR accepts and acknowledges its responsibility for requiring and obtaining a similar warranty and certification from each and every CONTRACTOR and subcontractor whose service the CONTRACTOR has secured in connection with the services to be rendered under this Agreement and shall forward evidence to PRDOH as to its compliance with this requirement.

E. Social Security and Income Tax Retentions: The CONTRACTOR will be responsible for rendering and paying the Federal Social Security and Income Tax Contributions for any amount owed as a result of the income from this Agreement.

rw
F. Government of Puerto Rico Municipal Tax Collection Center (CRIM, for its Spanish acronym): The CONTRACTOR certifies and guarantees that at the signing of this Agreement it has no current debt with regards to property taxes that may be registered with the Government of Puerto Rico's Municipal Tax Collection Center. The CONTRACTOR further certifies to be current with the payment of any and all property taxes that are or were due to the Government of Puerto Rico. The CONTRACTOR shall hand out, to the satisfaction of the PRDOH and whenever requested by the PRDOH during the term of this Agreement, the necessary documentation to support its compliance of this clause. The CONTRACTOR will deliver upon request any documentation requested under this clause as per request of PRDOH. During the Term of this Agreement, the CONTRACTOR agrees to pay and/or to remain current with any repayment plan agreed to by the CONTRACTOR with the Government of Puerto Rico with regards to its property taxes.

G. Income Tax Withholding: The PRDOH shall retain the corresponding amount from all payments made to the CONTRACTOR, as required by the Puerto Rico Internal Revenue Code. The PRDOH will advance such withholdings to the Government of Puerto Rico's Treasury Department (known in Spanish as *Departamento de Hacienda del Gobierno de Puerto Rico*). The PRDOH will adjust such withholdings provided the CONTRACTOR produces satisfactory evidence of partial or total exemption from withholding.

W
H. Compliance with Act No. 45 of April 18, 1935, as amended, 11 L.P.R.A. § 1, et seq.: The CONTRACTOR certifies and guarantees that at the signing of this Agreement has valid insurance issued by the State Insurance Fund Corporation (CFSE, for its Spanish Acronym), as established by Act No. 45, *supra*, known as the "Puerto Rico Workers' Accident Compensation Act".

I. Government of Puerto Rico's Agency for the Collection of Child Support (ASUME, for its Spanish acronym): The CONTRACTOR certifies and guarantees that at the signing of this Agreement that the CONTRACTOR nor any of its Partners, if applicable, have any debt or outstanding debt collection legal procedures with regards to child support payments that may be registered with the Government of Puerto Rico's Child Support Administration. The CONTRACTOR hereby certifies that it is a limited liability company organized and existing in good standing under the laws of the Government of Puerto Rico. The CONTRACTOR shall present, to the satisfaction of PRDOH, the necessary documentation to substantiate the same. The CONTRACTOR will be given a specific amount of time by PRDOH to deliver said documents.

J. **Compliance with Act No. 168-2000, as amended, 8 L.P.R.A. § 711 , et seq.:** The CONTRACTOR is in full compliance with Act No. 168-2000, as amended, known as "Act for the Improvement of Elderly Support of Puerto Rico."

K. **Compliance with Act No. 1-2012, as amended, 3 L.P.R.A. § 1854, et seq.:** The PRDOH and the CONTRACTOR hereby certify that in signing this Agreement they are in compliance with Act No. 1-2012, as amended, known as "Puerto Rico Government Ethics Act of 2011", in connection with the possibility of a conflict of interest.

L. **Clause of Governmental Ethics Certification of Absence of Conflict of Interests** - The CONTRACTOR certifies that: (1) No public servant of this executive agency has a pecuniary interest in this contract, purchase or commercial transaction. (2) No public servant of this executive agency has requested me or accepted from me, directly or indirectly, for him (her), for any member of his family unit or for any person, gifts, bonuses, favors, services, donations, loans or anything else of monetary value. (3) No public servant (s) requested or accepted any good of economic value, linked to this transaction, from any person of my entity as payment for performing the duties and responsibilities of their employment. (4) No public servant has requested from me, directly or indirectly, for him (her), for any member of her family unit, or for any other person, business or entity, some of economic value, including gifts, loans, promises, favors or services in exchange for the performance of said public servant is influenced in my favor or of my entity. (5) I have no kinship relationship, within the fourth degree of consanguinity and second by affinity, with any public servant who has the power to influence and participate in the institutional decisions of this executive agency.

M. **Ethics.** CONTRACTOR also acknowledges receipt and agrees to obey with the Anticorruption Code for the New Puerto Rico known in Spanish as "Código Anticorrupción para el Nuevo Puerto Rico".

N. **Non-Conviction.** The CONTRACTOR certifies that it has not been convicted nor accused of a felony or misdemeanor against the government, public faith and function, or that involves public property or funds, either federal or local in origin. Furthermore, CONTRACTOR also certifies that:

1. It has not been convicted, nor has pleaded guilty at a state or federal bar, in any jurisdiction of the United States of America, of crimes consisting of fraud, embezzlement or misappropriation of public funds, as stated in Act Number 2 of January 2, 2018, as amended, known as the Anti-Corruption Code for the New Puerto Rico, which prohibits the award of Offers or government contracts to those convicted of fraud, misappropriation of public fund.

2. It understands and accepts that any guilty plea or conviction for any of the crimes specified in Article 3 of said Act, will also result in the immediate cancellation of any contracts in force at the time of conviction, between the undersigned and whichever Government Agencies, Instrumentalities, Public Corporations, Municipalities and the Legislative or Judicial Branches.

3. It declares under oath the above mentioned in conformity with what is established as in Act Number 2 of January 2, 2018, as amended, known as the Anti-Corruption Code for the New Puerto Rico, which prohibits awarding Offers for government contracts, to those convicted of fraud, embezzlement or misappropriation of public funds.

4. The CONTRACTOR represents and guarantees that none of its employees, officials or agents have been convicted of a felony or misdemeanor as described in this sub-section. Moreover, the CONTRACTOR agrees to notify PRDOH should any employee, official, or agent is convicted of a felony or misdemeanor as described in this sub-section after the date of this Agreement. Said notice shall be made within **ten (10) business days** from the time of the conviction.

O. Other payments or compensation: The CONTRACTOR certifies that it does not receive payment or compensation for regular services rendered as an official or public employee to another government entity, agency, public corporation or municipality, and knows the ethical standards of his profession and assumes responsibility for his actions.

P. Consequences of Non-Compliance: The CONTRACTOR expressly agrees that the conditions outlined throughout this Section are essential requirements of this Agreement; thus, should any one of these representations, warrants, and certifications be incorrect, inaccurate or misleading, in whole or in part, there shall be sufficient cause for PRDOH to render this Agreement null and void and the CONTRACTOR reimburse to PRDOH all moneys received under this Agreement.

rw
XXIV. ACT NO. 18 OF OCTOBER 30, 1975, as amended, 2 L.P.R.A. secs. 97-98

The parties to this Agreement agree that its effective date will be subject to the due registration and remittance to the Office of the Comptroller of Puerto Rico. No rendering or consideration subject matter of this Agreement will be required before its registration at the Office of the Comptroller of Puerto Rico pursuant to Act No. 18 of October 30, 1975, as amended. The CONTRACTOR will be responsible for ensuring that this Agreement has been registered before the rendering of services by requesting a copy of the registered Agreement with its proper number and date of registry. No services under this Agreement will continue to be delivered after its effective date unless at the expiration date, an amendment signed by both parties and duly registered exists. No services performed in violation of this provision will be paid. The party violating this clause will be doing so without any legal authority, this action will be deemed as *ultra vires*.

XXV. MEMORANDUM NO. 2021-003; CIRCULAR LETTER 001-2021 OF THE OFFICE OF THE CHIEF OF STAFF OF THE GOVERNOR (SECRETARÍA DE LA GOBERNACIÓN) & THE OFFICE OF MANAGEMENT AND BUDGET (OFICINA DE GERENCIA Y PRESUPUESTO)

um
A. Interagency Services Clause: Both contracting parties acknowledge and agree that services retained may be provided to any entity of the Executive Branch with which the contracting entity makes an interagency agreement or by direct provision of the Office of the Chief of Staff of the Governor (*Secretaría de la Gobernación*). These services will be performed under the same terms and conditions in terms of hours of work and compensation set forth in this Agreement. For purposes of this clause, the term "Executive Branch entity" includes all agencies of the Government of Puerto Rico, as well as public instrumentalities and corporations and the Office of the Governor.

B. Termination Clause: The Chief of Staff (*Secretario de la Gobernación*) of the Governor shall have the power to terminate this Agreement at any time.

C. Contract Review Policy of the Financial Supervision and Administration Board for Puerto Rico: The parties acknowledge that the contractor has submitted the certification entitled "Contractor Certification Requirement" required in accordance

with the Contract Review Policy of the Financial Oversight and Management Board (FOMB) for Puerto Rico, effective as of November 6, 2017 as amended on October 30, 2020, signed by the Contractor's Executive Director (or another official with an equivalent position or authority to issue such certifications). A signed copy of the "Contractor's Certification Requirement" is included as **Attachment H** to this contract.

XXVI. MEMORANDUM NO. 2021-029; CIRCULAR LETTER NO. 013-2021 OF THE OFFICE OF THE CHIEF OF STAFF OF THE GOVERNOR (SECRETARÍA DE LA GOBERNACIÓN) & THE OFFICE OF MANAGEMENT AND BUDGET (OFICINA DE GERENCIA Y PRESUPUESTO):

- rw*
- A. The PRDOH certifies that the CONTRACTOR was selected as the provider of the services described in this agreement, pursuant to OE 2021-029.
 - B. The Parties certify that they acknowledge the provisions stated in OE 2021-029 and CC 013-2021. Any failure to comply with the requirements set forth in OE 2021-029 and CC 013-2021 will result in the termination of this agreement.
 - C. The CONTRACTOR certifies that it has informed PRDOH of any current contractual relationship with any government entities of the Government of Puerto Rico. The CONTRACTOR certifies that said entities are all the entities of the Government of Puerto Rico with which they maintain a contractual relationship. In addition, the CONTRACTOR recognizes and accepts that omitting any information regarding any current contractual relationship with any governmental entity could result in the termination of this agreement if so required by PRDOH.
 - D. The CONTRACTOR certifies that it has informed the PRDOH whether or not the entity is a public corporation whose shares are exchanged in a stock exchange properly regulated. In the event that the CONTRACTOR certifies that it is not a public corporation that exchanges shares in a stock change, the CONTRACTOR certifies it has completed the applicable certification as stated in CC-013-2021.

XXVII. FINANCIAL OVERSIGHT AND MANAGEMENT BOARD FOR PUERTO RICO (FOMB) POLICY: REVIEW OF CONTRACTS, AS MODIFIED ON APRIL 30, 2021, REGARDING PROFESSIONAL SERVICES

UN

The FOMB Policy requires that all agreements that contemplate recurring professional services that may be performed by appropriately trained government staff include a provision of compliance with the adequate transfer of skills and technical knowledge to the pertinent public sector personnel. This requirement shall not apply to contracts which contemplate non-recurring professional services or specialized professional services that may not be performed by existing staff at the applicable governmental entity, including as a result of independence requirements.

Accordingly, given that the agreements under CDBG-DR are non-recurring professional services or specialized professional services, the PRDOH certifies that the transfer of skills and technical knowledge required by the Certified Fiscal Plan is inapplicable given the non-recurring or specialized nature of the contracted services.

As mentioned before, HUD allocated funds for disaster recovery assistance to the Government of Puerto Rico under the CDBG-DR Program. These funds are intended to provide financial assistance to address unmet needs that arise and that are not covered by other sources of financial aid. In addition, with these allocations of funding under the Grant Agreement, the PRDOH will conduct a comprehensive recovery to benefit the residents of Puerto Rico.

XXVIII. COMPLIANCE WITH THE FINANCIAL OVERSIGHT AND MANAGEMENT BOARD FOR PUERTO RICO (FOMB) POLICY, REVIEW OF CONTRACTS

As part of the PRDOH contract process, and pursuant to Section 204(b)(2) of the "Puerto Rico Oversight, Management, and Economic Stability Act," 48 U.S.C. §2101, et seq., also known as "PROMESA", the Financial Oversight and Management Board for Puerto Rico (FOMB) require approval of certain contracts and amendments to assure that they "promote market competition" and "are not inconsistent with the approved fiscal plan." For the approval process, the FOMB requests, among other information, the Contractor Certification Requirement for its evaluation.

In compliance with the above, the CONTRACTOR represents and warrants that the information included in the Contractor Certification Requirement is complete, accurate and correct, and that any misrepresentation, inaccuracy or falseness in such Certification will render the contract null and void and CONTRACTOR will have the obligation to reimburse immediately to the Commonwealth any amounts, payments or benefits received from the Commonwealth under the proposed Amendment and original Agreement.

XXIX. COMPLIANCE WITH FEDERAL LAW, REGULATIONS, & EXECUTIVE ORDERS

1W
The CONTRACTOR acknowledges that HUD financial assistance will be used to fund the Agreement only. Also, the CONTRACTOR shall comply with all applicable Federal, state and local laws, rules, regulations, and policies relating to CDBG-DR and CDBG Program services. This includes without limitation, applicable Federal Registers; 2 C.F.R. part 200 Uniform Administrative Requirements, Cost Principles, and Audit Requirements for Federal Awards; Community Development Act of 1974; 24 C.F.R. part 570 Community Development Block Grant; applicable waivers; Fair Housing Act, 24 C.F.R. Part 35, 24 C.F.R. Part 58, 24 C.F.R. Part 135; National Historic Preservation Act, and any other applicable state laws or regulations, including the requirements related to nondiscrimination, labor standards, and the environment; and Action Plan amendments and HUD's guidance on the funds. Also, CONTRACTOR shall comply, without limitation, those set forth in **Attachment G** and in compliance with all the requirements described in **Attachment H**.

XXX. FEDERAL LAWS AND REGULATIONS APPLICABLE TO CONSTRUCTION CONTRACTS

A. COPELAND "ANTI-KICKBACK" ACT

1W
Salaries of personnel performing work under this Agreement shall be paid unconditionally and not less often than once a month without payroll deduction or rebate on any account except only such payroll deductions as are mandatory by law or permitted by the applicable regulations issued by the Secretary of Labor pursuant to the Copeland "Anti-Kickback Act" of June 13, 1934 (48 Stat. 948; 62 Stat. 740; 63 Stat. 108; Title 18 U.S.C. § 874; and Title 40 U.S.C. § 276c).

The CONTRACTOR, as well as any subcontracts, shall provide a weekly statement with respect to the wages paid to each of its employees engaged on work covered by the Copeland "Anti-Kickback Act" during the preceding weekly payroll period.¹ The CONTRACTOR, as well as any subcontractors, shall deliver each weekly statement within seven days after the regular payment date of the payroll period, to the PRDOH. After such examination and check as may be made, such statement, or a copy thereof, shall

¹ This statement shall be executed by the contractor or by an authorized officer or employee of the contractor who supervises the payment of wages, and shall be on the back of Form WH 347, "Payroll (For Contractors Optional Use)" or on any form with identical wording. Copies of WH 347 may be obtained from the Government contracting or sponsoring agency or from the Wage and Hour Division Web site at <http://www.dol.gov/whd/forms/index.htm> or its successor site.

be kept available, or shall be transmitted together with a report of any violation, in accordance with applicable procedures prescribed by the U.S. Department of Labor. The CONTRACTOR shall preserve his weekly payroll records for a period of 6 years from date of completion of this Agreement and also the Subrecipients must comply with the record retention requirements, as established in the policy on document handling, administration and accessibility, in accordance with the RKMA policy, and ensure that all documentations is always available for any internal or external tracing visit. Such payroll records shall be made available at all times for inspection by the contracting officer or his authorized representative, and by authorized representatives of the Department of Labor.

The CONTRACTOR, as well as any subcontractors, shall comply with all applicable "Anti-Kickback" regulations and shall insert HUD form 4010 and any additional provisions in all subcontracts covering work under this Agreement to ensure compliance by subcontractors with such regulations as applicable, and shall be responsible for the submission of affidavits and Statements of Compliance required of subcontractors thereunder except as the Secretary of Labor may specifically provide for variations of or exemptions from the requirements thereof.²

B. CONTRACT WORK HOURS AND SAFETY STANDARDS ACT

rw
The CONTRACTOR, as well as any subcontractors, shall comply with Sections 103 and 107 of the Contract Work Hours and Safety Standards Act (CWHSSA) (40 U.S.C. §§ 3701-3708) as supplemented by Department of Labor regulations (29 C.F.R. Part 5). Where applicable, all contracts awarded by the non-Federal entity in excess of \$100,000 that involve the employment of mechanics or labors. The provisions of CWHSSA apply to all labors and mechanic, including watchmen and guards. 40 U.S.C. Section 3701(b)(2).

The CONTRACTOR, as well as any subcontractors, agrees to compute the wages of every mechanic and laborer on the basis of a standard work week of forty (40) hours in accordance with and subject to the provisions of the CWHSSA. Any work in excess of the standard work week is permissible provided that the worker is compensated at a rate of no less that on and a half times the basic rate of pay for all hours worked in excess of forty (40) hours in the work week. The CONTRACTOR will not require any laborer or mechanic employed in the performance of this Agreement to work in surroundings or under working conditions that are unsanitary, hazardous, or dangerous to health or safety, as established under construction safety and health standards.

W
The CONTRACTOR, as well as any subcontractors, shall insert appropriate provisions of the CWHSSA in all subcontracts covering work under this Agreement to ensure compliance by subcontractors with such regulations, and shall be responsible for the submission of affidavits required of subcontractors thereunder except as the Secretary of Labor may specifically provide for variations of or exemptions from the requirements thereof.

The CONTRACTOR, as well as any subcontractors, shall comply with all regulations issued pursuant to that act and with other applicable Federal laws and regulations pertaining to labor standards.³

C. DAVIS-BACON ACT

The CONTRACTOR, as well as any subcontractors, shall comply with the Davis Bacon Act (40 U.S.C. §§ 3141-3148) as supplemented by the Department of Labor regulations (29 C.F.R. Part 5).

All laborers and mechanics employed by the CONTRACTOR, as well as any subcontractors, including employees of other governments, on construction, work assisted under this Agreement, and subject to the provisions of the federal acts and regulations listed in this paragraph, shall be paid wages at rates not less than those prevailing on similar construction in the locality as determined by the Secretary of Labor in accordance with the Davis-Bacon Act. The advertised specifications for every

² <https://www.dol.gov/agencies/whd/government-contracts/copeland-anti-kickback>

³ <https://www.dol.gov/agencies/whd/government-contracts/cwhssa>

contract in excess of \$2,000, for construction, alteration, or repair, including painting and decorating, of public buildings and public works. 40 U.S.C. Sec. 3142.⁴

The CONTRACTOR, as well as any subcontractors, shall pay all mechanics and laborers employed directly on the site of the work, unconditionally and at least once a week, and without subsequent deduction or rebate on any account, the full amounts accrued at time of payment, computed at wage rates not less than those stated in the advertised specifications, regardless of any contractual relationship which may be alleged to exist between the contractor or subcontractor and the laborers and mechanics. The CONTRACTOR will post the scale of wages to be paid in a prominent and easily accessible place at the site of the work.

There may be withheld from the CONTRACTOR so much of accrued payments as the contracting officer considers necessary to pay to laborers and mechanics employed by the contractor or any subcontractor on the work the difference between the rates of wages required by the contract to be paid laborers and mechanics on the work and the rates of wages received by the laborers and mechanics and not refunded to the contractor or subcontractors or their agents.

On a semi-annual basis, the CONTRACTOR shall submit Form HUD 4710 (Semi-Annual labor Standards Enforcement Report) to PRDOH. All covered subcontracts must include Davis-Bacon and other labor standards clauses and the applicable federal wage determinations as well as the local prevailing wage established in this contract. The Federal Labor Standards Provisions on Form HUD 4010 covers the Davis-Bacon and related acts expected in all subcontracts covering work under this Agreement to ensure compliance by subcontractors with such regulations, and shall be responsible for the submission of affidavits required of subcontractors thereunder except as the Secretary of Labor may specifically provide for variations of or exemptions from the requirements thereof.

The HUD Form 4010 and a Spanish translation of the original form is included as **Attachment J** to this contract. The attachment ensures contractors, with a predominant fluency in Spanish, are able to immediately reference labor requirements to ensure full compliance for Davis-Bacon and related Acts.

In addition, the applicable wage determination is included as **Attachment K** to this contract. The attachment guarantees that the contractors are informed of the prevailing wages to ensure compliance with federal and state regulations.

D. SECTION 109 OF THE HOUSING AND COMMUNITY DEVELOPMENT ACT OF 1974

The CONTRACTOR, as well as any subcontractors, shall comply with the provisions of Section 109 of the Housing and Community Development Act of 1974. No person in the United States shall on the grounds of race, color, national origin, religion or sex be excluded from participation in, be denied the benefits of, or be subjected to discrimination under any program or activity funded in whole or in part with funds made available under this title. Section 109 further provides that discrimination on the basis of age under the Age Discrimination Act of 1975 or with respect to an otherwise qualified handicapped individual as provided in Section 504 of the Rehabilitation Act of 1973, as amended, is prohibited.

E. FAIR LABOR STANDARDS ACT OF 1938, AS AMENDED

The CONTRACTOR, as well as any subcontractors, shall comply with the provisions of the Fair Labor Standards Act (29 U.S.C. §§ 201-219), which governs such matters as Federal minimum wage rates and overtime, as supplemented by the Department of Labor regulations (29 C.F.R. Parts 500-899).

⁴ Section 110 of the Act, determines the DBRA applicability to CDBG-DR. The Act further provides that Section 5310 (Section 110 of the Act) apply to the rehabilitation of residential property only if such property contains not less than eight (8) units. (8 units or more)

The CONTRACTOR agrees to comply and implement the applicable regulations of the U.S. Department of Labor at 29 C.F.R. Parts 500-899.⁵

XXXI. CDBG-DR POLICIES AND PROCEDURES

In addition to what is established in this Agreement, the CONTRACTOR shall comply with all CDBG-DR program specific and general policies and procedures, including, but not limited to, the Contract and Subrecipient Agreement Manual, OS&H Guideline, MWBE Policy, Procurement Manual for the CDBG-DR Program, URA & ADP Guidelines, Cross Cutting Guidelines, AFWAM Policy, Section 3 Policy, Personally Identifiable Information, Confidentiality, and Nondisclosure Policy and Conflict of Interest and Standards of Conduct Policy, as found in the CDBG-DR Website (www.cdbg-dr.pr.gov), which are herein included and made integral part of this Agreement, as they may be updated from time to time, and reporting requirements as established by the PRDOH.

XXXII. SECTION 3 CLAUSE

A. The work to be performed under this contract is subject to the requirements of Section 3 of the Housing and Urban Development Act of 1968, as amended, 12 U.S.C. 1701u (Section 3). The purpose of Section 3 is to ensure that employment and other economic opportunities generated by HUD assistance or HUD-assisted projects covered by Section 3, shall, to the greatest extent feasible, be directed to low- and very low-income persons, particularly persons who are recipients of HUD assistance for housing.

B. The parties to this contract agree to comply with HUD's regulations in 24 C.F.R. part 75, which implement Section 3. As evidenced by their execution of this contract, the parties to this contract certify that they are under no contractual or other impediment that would prevent them from complying with the part 75 regulations.

C. The contractor agrees to send to each labor organization or representative of workers with which the contractor has a collective bargaining agreement or other understanding, if any, a notice advising the labor organization or workers' representative of the contractor's commitments under this Section 3 clause, and will post copies of the notice in conspicuous places at the work site where both employees and applicants for training and employment positions can see the notice. The notice shall describe the Section 3 preference, shall set forth minimum number and job titles subject to hire, availability of apprenticeship and training positions, the qualifications for each; the name and location of the person(s) taking applications for each of the positions; and the anticipated date the work shall begin.

D. The contractor agrees to include this Section 3 clause in every subcontract subject to compliance with regulations in 24 C.F.R. part 75 and agrees to take appropriate action, as provided in an applicable provision of the subcontract or in this Section 3 clause, upon a finding that the subcontractor is in violation of the regulations in 24 C.F.R. part 75. The contractor will not subcontract with any subcontractor where the contractor has notice or knowledge that the subcontractor has been found in violation of the regulations in 24 C.F.R. part 75.

E. The contractor acknowledges that subrecipients, contractors, and subcontractors are required to meet the employment, training, and contraction requirements of 24 CFR 75.19, regardless of whether Section 3 language is included in recipient or subrecipient agreements, program regulatory agreements, or contracts.

⁵ <https://www.dol.gov/agencies/whd/flsa>

F. The contractor will certify that any vacant employment positions, including training positions, that are filled (1) after the contractor is selected but before the contract is executed, and (2) with persons other than those to whom the regulations of 24 C.F.R. part 75 require employment opportunities to be directed, were not filled to circumvent the contractor's obligations under 24 C.F.R. part 75.

G. Noncompliance with HUD's regulations in 24 C.F.R. part 75 may result in sanctions, termination of this contract for default, and debarment or suspension from future HUD assisted contracts.

H. With respect to work performed in connection with Section 3 covered Indian housing assistance, section 7(b) of the Indian Self-Determination and Education Assistance Act (46 U.S.C. § 5307) also applies to the work to be performed under this contract. Section 7(b) requires that to the greatest extent feasible (i) preference and opportunities for training and employment shall be given to Indians, and (ii) preference in the award of contracts and sub contracts shall be given to Indian organizations and Indian-owned Economic Enterprises. Parties to this contract that are subject to the provisions of Section 3 and section 7(b) agree to comply with Section 3 to the maximum extent feasible, but not in derogation of compliance with section 7(b).

I. The Contractor agrees to submit, and shall require its subcontractors to submit to them, quarterly reports to the PRDOH detailing the total number of labor hours worked on the Section 3 Project, the total number of labor hours worked by Section 3 Workers, and the total number of hours worked by Targeted Section 3 Workers, and any affirmative efforts made during the quarter to direct hiring efforts to low- and very low-income persons, particularly persons who are Section 3 Workers and Targeted Section 3 Workers.

XXXIII. BYRD ANTI-LOBBYING AMENDMENT, 31 U.S.C. § 1352

The CONTRACTOR certifies, to the best of his or her knowledge, that:

A.- No Federal appropriated funds have been paid or will be paid, by or on behalf of the undersigned, to any person for influencing or attempting to influence an officer or employee of an agency, a Member of Congress, an officer or employee of Congress, or an employee of a Member of Congress in connection with the awarding of any Federal contract, the making of any Federal grant, the making of any Federal loan, the entering into of any cooperative agreement, and the extension, continuation, renewal, amendment, or modification of any Federal contract, grant, loan, or cooperative agreement.

B. - If any funds other than Federal appropriated funds have been paid or will be paid to any person for influencing or attempting to influence an officer or employee of any agency, a Member of Congress, an officer or employee of Congress, or an employee of a Member of Congress in connection with this Federal contract, grant, loan, or cooperative agreement, the undersigned shall complete and submit Standard Forms-LLL, "Disclosure of Lobbying Activities," in accordance with its instructions.

C. The CONTRACTOR shall require that the language of this certification be included in the award documents for all subawards at all tiers (including subcontracts, subgrants, and contracts under grants, loans, and cooperative agreements) and that all sub recipients shall certify and disclose accordingly. This certification is a material representation of fact upon which reliance was placed when this transaction was made or entered into. Submission of this certification is a

prerequisite for making or entering into this transaction imposed by 31, U.S.C. §1352 (as amended by the Lobbying Disclosure Act of 1995). The CONTRACTOR acknowledges that any person who fails to file the required certification shall be subject to a civil penalty of not less than \$10,000 and not more than \$100,000 for each such failure. The CONTRACTOR certifies or affirms the truthfulness and accuracy of each statement of its certification and disclosure, if any. In addition, the CONTRACTOR understands and agrees that the provisions of 31 U.S.C. §3801 *et seq.*, apply to this certification and disclosure, if any.

XXXIV. EQUAL OPPORTUNITY

- A.- The CONTRACTOR will not discriminate against any employee or applicant for employment because of race, color, religion, sex, sexual orientation, gender identity or national origin. The CONTRACTOR will take affirmative action to ensure that applicants are employed, and that employees are treated during employment without regard to their race, color, religion, sex, or national origin. Such action shall include, but not be limited to the following: Employment, upgrading, demotion, or transfer; recruitment or recruitment advertising; layoff or termination; rates of pay or other forms of compensation; and selection for training, including apprenticeship. The CONTRACTOR agrees to post in conspicuous places, available to employees and applicants for employment, notices to be provided setting forth the provisions of this nondiscrimination clause.
- B. - The CONTRACTOR will, in all solicitations or advertisements for employees placed by or on behalf of the CONTRACTOR, state that all qualified applicants will receive considerations for employment without regard to race, color, religion, sex, or national origin.
- 700*
C. When applicable, the CONTRACTOR will send to each labor union or representative of workers with which he has a collective bargaining agreement or other contract or understanding, a notice to be provided advising the said labor union or workers' representatives of the CONTRACTOR's commitments under this Section and shall post copies of the notice in conspicuous places available to employees and applicants for employment.
- D.- The CONTRACTOR will comply with all provisions of Executive Order 11246 of September 24, 1965, as amended by Executive Order 11375 of October 13, 1967, and as supplemented by the rules, regulations, and relevant orders of the United States Secretary of Labor.
- 112*
E. - The CONTRACTOR will furnish all information and reports required by Executive Order 11246 of September 24, 1965, as amended, and by rules, regulations, and orders of the Secretary of Labor, or pursuant thereto, and will permit access to his books, records, and accounts by the administering agency and the Secretary of Labor for purposes of investigation to ascertain compliance with such rules, regulations, and orders.
- F. - In the event of the CONTRACTOR's noncompliance with the nondiscrimination clauses of this Agreement or with any of the said rules, regulations, or orders, this Agreement may be canceled, terminated, or suspended in whole or in part and the CONTRACTOR may be declared ineligible for further Government contracts or federally assisted construction contracts in accordance with procedures authorized in Executive Order 11246 of September 24, 1965, as amended, and such other sanctions as may be imposed and remedies invoked as provided in

Executive Order 11246 of September 24, 1965, as amended, or by rule, regulation, or order of the Secretary of Labor, or as otherwise provided by law.

- G. The CONTRACTOR will include the portion of the sentence immediately preceding paragraph (A) and the provisions of paragraphs (A) through (F) in every subcontract or purchase order unless exempted by rules, regulations, or orders of the Secretary of Labor issued pursuant to Section 204 of Executive Order 11246 of September 24, 1965, as amended, so that such provisions will be binding upon each subcontractor or vendor. The CONTRACTOR will take such action with respect to any subcontract or purchase order as the administering agency may direct as a means of enforcing such provisions, including sanctions for noncompliance. Provided, however, that in the event a CONTRACTOR becomes involved in, or is threatened with, litigation with a subcontractor or vendor as a result of such direction by the administering agency, the CONTRACTOR may request the United States to enter into such litigation to protect the interests of the United States.

XXXV.CLEAN AIR ACT

- A.- The CONTRACTOR agrees to comply with all applicable standards, orders or regulations issued pursuant to the Clean Air Act, as amended, 42 U.S.C. § 7401 et seq.
- nw*
B. - The CONTRACTOR agrees to report each violation to the PRDOH and understands and agrees that the PRDOH will, in turn, report each violation as required to assure notification to the Government of Puerto Rico, HUD, and the appropriate Environmental Protection Agency Regional Office.
- C. The CONTRACTOR agrees to include these requirements in each subcontract exceeding \$150,000 financed in whole or in part with Federal assistance provided by HUD.

XXXVI.SOLID WASTE DISPOSAL ACT

- uw*
1) In the performance of this contract, the CONTRACTOR shall make maximum use of products containing recovered materials that are Environmental Protection Agency (EPA)- designated items unless the product cannot be acquired:
- Competitively within a timeframe providing for compliance with the contract performance schedule;
 - Meeting contract performance requirements; or
 - At a reasonable price.
- 2) Information about this requirement, along with the list of EPA- designated items, is available at EPA's Comprehensive Procurement Guidelines web site, <https://www.epa.gov/smm/comprehensive-procurement-guideline-cpg-program>.
- 3) Contractor must comply with section 6002 of the Solid Waste Disposal Act, as amended by the Resource Conservation and Recovery Act. The requirements of Section 6002 include:
- procuring only items designated in guidelines of the EPA at 40 C.F.R. part 247 that contain the highest percentage of recovered materials practicable, consistent with maintaining a satisfactory level of competition, where the purchase price of the item exceeds ten thousand dollars (\$10,000) or the value of the quantity acquired during the preceding fiscal year exceeded ten thousand dollars (\$10,000);

- b. procuring solid waste management services in a manner that maximizes energy and resource recovery; and
- c. establishing an affirmative procurement program for procurement of recovered materials identified in the EPA guidelines.

XXXVII. WATER POLLUTION CONTROL ACT

- A.- The CONTRACTOR agrees to comply with all applicable standards, orders or regulations issued pursuant to the Federal Water Pollution Control Act, as amended, 33 U.S.C. § 1251, *et seq.*
- B.- The CONTRACTOR agrees to report each violation to the PRDOH and understands and agrees that the PRDOH will, in turn, report each violation as required to assure notification to the Government of Puerto Rico, HUD, and the appropriate Environmental Protection Agency Regional Office.
- C. The CONTRACTOR agrees to include these requirements in each subcontract exceeding \$150,000 financed in whole or in part with Federal assistance provided by HUD.

XXXVIII. DRUG FREE WORKPLACE

rw
The CONTRACTOR should establish procedures and policies to promote a Drug-Free workplace. Further, the CONTRACTOR should notify all employees of its policy for maintaining a Drug-Free workplace, and the penalties that may be imposed for drug abuse violations occurring in the workplace. Further, the CONTRACTOR shall notify the PRDOH if any of its employees is convicted of a criminal drug offense in the workplace no later than **ten (10) days** after such conviction.

XXXIX. SUSPENSION AND DEBARMENT

- A.- This Agreement is a covered transaction for purposes of 2 C.F.R. part 180 and 2 C.F.R. part 2424. As such, the CONTRACTOR is required to verify that none of the CONTRACTOR, its principals (defined at 2 C.F.R. § 180.995), or its affiliates (defined at 2 C.F.R. § 180.905) are excluded (defined at 2 C.F.R. § 180.940) or disqualified (defined at 2 C.F.R. § 180.935).
- mm*
B.- The CONTRACTOR must comply with 2 C.F.R. part 180, subpart C and 2 C.F.R. part 2424, and must include a requirement to comply with these regulations in any lower tier covered transaction it enters into.
- C. This certification is a material representation of fact relied upon by PRDOH. If it is later determined that the CONTRACTOR did not comply with 2 C.F.R. part 180, subpart C and 2 C.F.R. part 2424, in addition to remedies available to PRDOH, the Federal Government may pursue available remedies, including but not limited to suspension and/or debarment.
- D.- The CONTRACTOR agrees to comply with the requirements of 2 C.F.R. part 180, subpart C and 2 C.F.R. part 2424, while this Agreement is valid. The CONTRACTOR further agrees to include a provision requiring such compliance in its lower tier covered transactions.

XL. NO OBLIGATION BY THE FEDERAL GOVERNMENT

The Federal Government is not a party to this Agreement and is not subject to any obligations or liabilities to the non-Federal entity, CONTRACTOR, or any other party pertaining to any matter resulting from the Agreement.

XLI. PROGRAM FRAUD & FALSE OR FRAUDULENT STATEMENTS OR RELATED ACTS

The CONTRACTOR acknowledges that 31 U.S.C. Chapter 38 (Administrative Remedies for False Claims and Statements) applies to the CONTRACTOR's actions pertaining to this Agreement.

XLII. BANKRUPTCY

In the event that CONTRACTOR files for bankruptcy protection, the Government of Puerto Rico and PRDOH may deem this Agreement null and void, and terminate this Agreement without notice.

XLIII. ENTIRE AGREEMENT

nw
This Agreement and all its attachments represent the entire and integrated agreement between PRDOH and the CONTRACTOR and supersede all prior negotiations, representations, agreements and/or understandings of any kind. This Agreement may be amended only by written document signed by both PRDOH and the CONTRACTOR.

XLIV. MODIFICATION OF AGREEMENT

Any modification of this Agreement or additional obligation assumed by either party in connection with this Agreement shall be binding only if written and signed by both parties, and its authorized representatives. Those amendments shall make specific reference to this Agreement, comply with programmatic policies, procedures, and guidelines. Such amendments shall not invalidate this Agreement, nor relieve or release the Parties from their obligations under this Agreement.

AK
However, PRDOH reserves the right to notify in writing to CONTRACTOR any applicable policies, procedures, regulations, requirements, guidelines, or change in law, whether existing or to be established, as well as changes and/or amendments thereof, and the notified policies, procedures, regulations, requirements, guidelines and laws shall be deemed incorporated by reference to this Agreement without the need of executing a separate written and signed amendment.

XLV. BINDING EFFECT

This Agreement shall be binding upon and shall inure to the benefit of PRDOH and the CONTRACTOR, their successors and assigns.

The CONTRACTOR shall not assign this Agreement, in whole or in part, without the prior written consent of PRDOH, and any attempted assignment not in accordance herewith shall be null and void and of no force or effect.

XLVI. ASSIGNMENT OF RIGHTS

The rights of each party hereunder are personal to that party and may not be assigned or otherwise transferred to any other person, contractor, corporation, or other entity without the prior, express, and written consent of the other party.

XLVII. NON-WAIVER

The failure or delay of either party to insist upon the performance of and/or the compliance with any of the terms and conditions of this Agreement shall not be construed as a waiver of such terms and conditions or the right to enforce compliance with such terms and conditions.

XLVIII. ORDER OF PRECEDENCE

In the event of an inconsistency in this Agreement or if a conflict occurs between this Agreement and any Attachment, Appendix, Exhibit, or Schedule, unless otherwise specifically stated in those documents, the order of precedence shall be: Federal laws, regulations, and policies applicable to this Agreement, this Contract and the HUD General Provisions (Attachment G), the Scope of Work (Attachment C), the Cost Form (Attachment D), and lastly, the CONTRACTOR's proposal (Attachment B).

XLIX. GOVERNING LAW JURISDICTION

This Agreement shall be governed by, interpreted, and enforced in accordance with the laws of the Government of Puerto Rico and any applicable federal laws and regulations. The parties further agree to assert any claims or causes of action that may arise out of this Agreement in the Puerto Rico Court of First Instance, Superior Court of San Juan, Puerto Rico.

L. CONSOLIDATIONS, MERGERS, CHANGE OF NAME, OR DISSOLUTIONS

A. Consolidation or Merger

In the event that the signing party (e.g. Subrecipient, Contractor, or Subcontractor) of the Agreement with the PRDOH moves for a consolidation or merger with another entity (private or public), by its discretion or otherwise, written notice of such decision or event shall be delivered to the PRDOH **at least fifteen (15) business days prior to the effective date** of the consolidation or merger. The notice shall include, but not limited to, a description of: the expected effective date of the consolidation or merger; name of each of the constituent entities moving to consolidate or merge into the single resulting or surviving entity; the proposed name of the resulting entity (in case of a consolidation) or the name of the surviving entity (in case of a merger) if necessary; reference to the projected capacity of the resulting or surviving entity to comply with the terms, conditions, obligations, tasks, services, and performance goals or requirements included in the Agreement as well as its Exhibits or Attachments; and a brief summary of the proposed plan to achieve the transition of duties (Scope of Work or Scope of Services), tasks, and performance goals or requirements to the resulting or surviving entity.

Upon the consolidation or the merger becoming effective, and supporting evidence of such event is notified to PRDOH, execution of an Amendment to the Agreement may follow. The Amendment would include, but not limited to, modifications to the clauses that refer to the identity, personal circumstances, address, and any other information related to the signing party deemed relevant by PRDOH for the execution of the Amendment. **No amendment to the Agreement will be necessary if the Subrecipient, Contractor, or Subcontractor becomes the surviving entity following a merger.**

Failure to comply with any of the before mentioned conditions, may result in the activation of the termination clauses provided in the Agreement.

B. Change of Name

In the event that the signing party (e.g. Subrecipient, Contractor, or Subcontractor) of the Agreement with the PRDOH initiates a change of name process, written notice of such decision or event shall be delivered to the PRDOH **at least fifteen (15) business days** prior to the effective date of such event. The notice shall include, but not limited to, a description of: the expected effective date of the change of name; the proposed name; inform of any change of address; and reference of any change in the capacity of the entity to comply with the terms, conditions, obligations, tasks, services, and performance goals or requirements included in the Agreement, as well as its Exhibits or Attachments.

Upon the change of name becoming effective, and supporting evidence of such event is notified to PRDOH, execution of an Amendment to the Agreement may follow. The Amendment would include, but not limited to, modifications to the clauses that refer to the identity, personal circumstances, address, and any other information related to the signing party deemed relevant by PRDOH for the execution of the Amendment.

Failure to comply with any of the before mentioned conditions, may result in the activation of the termination clauses provided in the Agreement.

C. Dissolution

new
In the event that the signing party (e.g. Subrecipient, Contractor, or Subcontractor) of the Agreement with the PRDOH moves for dissolution of the entity, written notice of such decision or event shall be delivered to the PRDOH **at least fifteen (15) business days** prior to the effective date of such event. The notice shall include, but not limited to, a description of the expected effective date of the dissolution; and contact information of one or more of its directors, officials or agents. Upon dissolution, becoming effective, and supporting evidence of such event is notified to PRDOH, termination of the Agreement will follow. Consequently, the signing party acknowledges and agrees to provide to the PRDOH, after termination of the Agreement, the assistance reasonably requested to facilitate the orderly transfer of responsibility for performance of the tasks or services to the PRDOH or a third party designated by the PRDOH. Moreover, all finished or unfinished records (files, data, work product) connected with this Agreement will be turned over to PRDOH following the Agreement termination.

LI. HEADINGS

The titles to the paragraphs of this Agreement are solely for reference purposes and the convenience of the parties and shall not be used to explain, modify, simplify, or aid in the interpretation of the provisions of this Agreement.

LII. FEDERAL FUNDING

new
The fulfillment of this Agreement is based on those funds being made available to the PRDOH as the lead administrative agency for Recovery. All expenditures under this Agreement must be made in accordance with this Agreement, the policies and procedures promulgated under the CDBG-DR Program, and any other applicable laws. Further, CONTRACTOR acknowledges that all funds are subject to recapture and repayment for non-compliance.

LIII. RECAPTURE OF FUNDS

PRDOH may recapture payments it makes to CONTRACTOR that (i) exceed the maximum allowable rates; (ii) are not allowed under applicable laws, rules, or regulations; or (iii) are otherwise inconsistent with this Agreement, including any unapproved expenditures. CONTRACTOR must refund such recaptured payments within **thirty (30) business days** after the PRDOH issues notice of recapture to CONTRACTOR.

LIV. OVERPAYMENT

CONTRACTOR shall be liable to the PRDOH for any costs disallowed pursuant to financial and/or compliance audit(s) of funds received under this Agreement. CONTRACTOR shall reimburse such disallowed costs from funds other than those CONTRACTOR received under this Agreement.

LV. SEVERABILITY

If any provision of this Agreement shall operate or would prospectively operate to invalidate the Agreement in whole or in part, then such provision only shall be deemed severed and the remainder of the Agreement shall remain operative and in full effect.

LVI. COUNTERPARTS

This Agreement may be executed in any number of counterparts, each of whom shall be deemed to be an original, however, all of which together shall constitute one and the same instrument. If the Agreement is not executed by the PRDOH within **thirty (30) calendar days** of execution by the other party, this Agreement shall be null and void.

LVII. SURVIVAL OF TERMS AND CONDITIONS

rw
The terms and conditions of this Agreement related to the following subjects shall survive the termination or expiration of this Agreement: interpretive provisions; consideration; warranties; general affirmations, federal assurances, federal and state certifications; CDBG-DR and state funding, recapture of CDBG-DR and/or state funds, overpayment of CDBG-DR and/or state funds; ownership and intellectual property, copyright; records retention methods and time requirements; inspection, monitoring and audit; confidentiality; public records; indemnification and liability; infringement of intellectual property rights; independent contractor relationship; compliance with laws; notices; choice of law and venue; severability; dispute resolution; consolidations, merger, change of name, and dissolution. Terms and conditions that, explicitly or by their nature, evidence the Parties' intent that they should survive the termination or expiration of this Agreement shall so survive.

W
IN WITNESS THEREOF, the parties hereto execute this Agreement in the place and on the date first above written.

DEPARTMENT OF HOUSING

SYNERLUTION ENERGY, LLC

William O. Rodríguez

William O. Rodríguez, Esq.,
Secretary

Irving Cruz Vadi

Irving Cruz Vadi
Managing Director
DUNS No. 118347695



GOVERNMENT OF PUERTO RICO
DEPARTMENT OF HOUSING

**Notice of Award
Request for Proposals
Photovoltaic Systems And Water Storage Systems
Acquisition And Installation Services
CDBG-DR-IFB-2021-01**

NOTICE OF AWARD

August 12, 2021

Irving Cruz Vadi
Synerlution Energy, LLC
2221 Militar Ave., Suite 103
Isabela, PR 00662

irving.cruz@synerlution.com

rw

**Re: Request for Proposals No. CDBG-DR-IFB-2021-01
Photovoltaic Systems And Water Storage System Acquisition And Installation
Services for the Community Energy and Water Resilience Instalation Program**

Dear Mr. Cruz Vadi,

AK

The Bid Board of the Puerto Rico Department of Housing (the "Board") with quorum duly constituted, pursuant Article 2, Section 2.8, 1 of the Regulation No. 6106 of February 25, 2000, known as the Regulation for Bids of the Department of Housing and its Components (Regulation No. 6106), as amended and Article II, Section 2.1 (e) of the Procurement Manual for the CDBG-DR Program, Regulation No. 9205, of August 4, 2020, efective on September 5, 2020 (Regulation 9205), upon evaluation of the recommendation issued by the CDBG-DR Procurement Division regarding the process for the Photovoltaic Systems And Water Storage Systems Acquisition And Installation Services Under The Community Energy And Water Resilience Installation Program, under Invitation For Bids No. CDBG-DR-IFB-2021-01 (IFB), decided to award the IFB to Pura Energía, Inc., GenPower, Green Energy & Fuels, Inc, Aireko Energy Solution, LLC, and Synerlution Energy, LLC. Five responsive and responsible firms whose Bids are the most advantageous and complied with the overall requirements of the solicitation set forth in the IFB. **(Exhibit I)**

On April 14, 2021, Synerlution Energy, LLC submitted a Bid in response to this IFB. In addition to the Proposal submitted by Synerlution Energy, LLC the PRDOH received sixteen (16) more Bids for a total of seventeen (17).

The Procurement Division evaluated the Bids based on the criteria stated in the IFB. Initial evaluation considered the Mandatory Requirements stated in Section 6. Pursuant to the terms of the IFB, Bidders shall comply with the Mandatory Requirements in order for their Bids to be evaluated on their technical and cost aspects. Mandatory Requirements were evaluated as either "Pass" or "Fail". If the Bidder met all Mandatory Requirements of this IFB, the Bid was noted with a "Pass" on the Mandatory Requirements evaluation. If the Bid did not meet all Mandatory Requirements of this IFB, the Bid was noted with a "Fail" in the Mandatory Requirements evaluation. In addition, pursuant with Section 8.1 of the IFB, the PRDOH Procurement Division also evaluated the specifications of the goods and services submitted by Bidders with their Bids to ensure that they complied with the specifications set forth in the Scope of Work.

A summary of the evaluation of the Bids, including results for mandatory requirements and the evaluation of the goods and services is included in **Table 1**.

Table 1: Evaluation Summary for Bidders

	Bidder	Bid Amount	Mandatory Requirements	Good And Services (Specifications)
1	Steam & Combustion Technology	\$ 113,901,630.00	Fail	N/A
2	Pura Energía, Inc.	\$ 7,950,000.00	Pass	Responsive
3	Thompson Construction Group	\$ 142,662,015.00	Pass	Responsive
4	CF Breeze Recovery	\$ 123,262,630.00	Pass	Responsive
5	Excel Contractors	\$ 126,852,509.00	Pass	Responsive
6	Yates-Bird, LLC	\$ 126,640,130.00	Pass	Responsive
7	CRM, JV	\$ 117,435,130.00	Pass	Responsive
8	Venegas Construction Corp.	\$ 77,130,130.00	Fail	N/A
9	Dynamic Construction Group, LLC	\$ 64,908,690.00	Pass	Not Responsive
10	Genesis Security Services d/b/a GenPower	\$ 7,997,154.40	Pass	Responsive
11	Synerlution Energy, LLC	\$ 97,375,130.00	Pass	Responsive
12	Power Solar, LLC	\$ 9,063,015.00	Pass	Not Responsive
13	Green Energy & Fuels, Inc.	\$ 9,119,894.17	Pass	Responsive
14	F & R Construction Group, Inc.	\$ 109,000,880.00	Pass	Responsive
15	Aireko Energy Group, LLC	\$ 77,337,010.00	Pass	Responsive
16	Sunnova Energy Corp.	\$ 114,209,505.00	Pass	Not Responsive
17	Caribe Tecno, CRL	\$ 113,364,380.00	Pass	Responsive

Synerlution Energy, LLC passed the mandatory requirements evaluation. About the good and services evaluation, Synerlution Energy, LLC was responsive for the services of the IFB. After thoroughly evaluating the costs proposals, the Procurement Division determined that Synerlution Energy, LLC costs were reasonable for the services.

In accordance to the Board Resolution, the award would result in the following contract distribution:

Table 2: Distribution of units among Contractors

Equipment Description	Level 1 Contractors		Level 2 Contractors		Total of Units
	Units	Amount of Contractors	Units	Amount of Contractors	
PV System with Battery Storage and related Services					
3 kW DC with 9kWh/day Battery Storage	1,075 ea	2	450 ea	3	3,500
4.3 kW DC with 12.8 kWh/day Battery Storage	72.5 ea ¹	2	35 ea	3	250
Water Storage System and related Services					
500 Gallons	772.5 ea ²	2	485 ea	3	3,000

Therefore, according to the IFB, the Procurement Division recommends a contract to:

- **GenPower** for the total amount of **\$7,747,154.40** and a two-year term with optional extension of up to one additional year distribute as shown in **Table 3**.

Table 3: GenPower Contract Distribution

Equipment Description	Price per Unit	Qty.	Total
PV System with Battery Storage and related Services			
3 kW DC with 9kWh/day Battery Storage	\$13,657.10	450	\$6,145,695.00
4.3 kW DC with 12.8 kWh/day Battery Storage	\$16,553.44	35	\$579,370.40
Water Storage System and related Services			
500 Gallons	\$2,107.40	485	\$1,022,089.00
Total (PV System + Water Storage System):			\$7,747,154.40

- **Pura Energía, Inc.**, for the total amount of **\$7,700,000.00** and a two-year term with optional extension of up to one additional year distribute as shown in **Table 4**.

Table 4: Pura Energía Inc. Contract Distribution

Equipment Description	Price per Unit	Qty.	Total
PV System with Battery Storage and related Services			

¹ Since the units cannot be divided in half the lowest of the two Level 1 Contractor will be awarded 73 units of the 4.3 kW DC with 12.8 kWh/day Battery Storage, PV System.

² Since the units cannot be divided in half the lowest of the two Level 1 Contractor will be awarded 773 units of the 500 Water Storage System.

3 kW DC with 9kWh/day Battery Storage	\$14,300.00	450	\$6,435,000.00
4.3 kW DC with 12.8 kWh/day Battery Storage	\$16,050.00	35	\$561,750.00
Water Storage System and related Services			
500 Gallons	\$1,450.00	485	\$703,250.00
Total (PV System + Water Storage System):			\$7,700,000.00

- **Green Energy & Fuels, Inc.**, for the total amount of **\$8,847,805.65** and a two-year term with optional extension of up to one additional year distribute as shown in **Table 5**.

Table 5: Green Energy and Fuels, Inc. Contract Distribution

Equipment Description	Price per Unit	Qty.	Total
PV System with Battery Storage and related Services			
3 kW DC with 9kWh/day Battery Storage	\$16,332.97	450	\$7,349,836.50
4.3 kW DC with 12.8 kWh/day Battery Storage	\$22,395.03	35	\$783,826.05
Water Storage System and related Services			
500 Gallons	\$1,472.46	485	\$714,143.10
Total (PV System + Water Storage System):			\$8,847,805.65

7W

- **Aireko Energy Solution, LLC** for the total amount of **\$21,964,812.50** and a two-year term with optional extension of up to one additional year distribute as shown in **Table 6**.

Table 6: Aireko Energy Solution, LLC Contract Distribution

Equipment Description	Price per Unit	Qty.	Total
PV System with Battery Storage and related Services			
3 kW DC with 9kWh/day Battery Storage	\$16,379.18	1,075	\$17,607,618.50
4.3 kW DC with 12.8 kWh/day Battery Storage	\$21,027.00	73	\$1,534,971.00
Water Storage System and related Services			
500 Gallons	\$3,651.00	773	\$2,822,223.00
Total (PV System + Water Storage System):			\$21,964,812.50

AM

- **Synerlution** for the total amount of **\$27,827,300.00** and a two-year term with optional extension of up to one additional year distribute as shown in **Table 7**.

Table 7: Synerlution Contract Distribution

Equipment Description	Price per Unit	Qty.	Total
PV System with Battery Storage and related Services			
3 kW DC with 9kWh/day Battery Storage	\$20,300.00	1,075	\$21,822,500.00
4.3 kW DC with 12.8 kWh/day Battery Storage	\$25,500.00	72	\$1,836,000.00
Water Storage System and related Services			
500 Gallons	\$5,400.00	772	\$4,168,800.00
Total (PV System + Water Storage System):			\$27,827,300.00

The list of Bidders, which is attached hereto and made an integral part hereof as **Exhibit II**, details the names, addresses and contact information of all Bidders that submitted a Bid in response to the IFB.

rw
 Any person, party or entity that considers itself having been adversely affected by an award determination of the Bid Board made under the provisions of the Regulation 9205, may file a petition for reconsideration with the Bid Review Board (Request for Reconsideration) within 20 days from the date on which a copy of the Award Notice was duly notified in accordance with Section 3.19 of Act 38-2017, Uniform Administrative Procedures Act of the Government of Puerto Rico. Simultaneously, with the filing of the Request for Reconsideration, said person, party or entity shall submit a copy of the Request for Resonsideration to all the parties in the process and to the Puerto Rico Department of Housing (PRDOH). Alternatively, a petition for review may be filed before the Court of Appeals of Puerto Rico.

W
 The Bid Review Board shall consider the motion for reconsideration within thirty (30) calendar days from the date of filing thereof, which term the Review Board may extend once for just cause for an additional period of fifteen (15) calendar days. If the Review Board issues a decision on the motion for reconsideration, the term to file a request for judicial review before the Court of Appeals will begin as of the date of deposit of a copy of the corresponding notice with the U.S. Postal Service. If the Review Board does not issue a decision on the motion for reconsideration within the term allowed by law, the motion will be deemed denied as of right, and the term to file a request for judicial review will begin to run as of the date thereof, as provided in Section 3.19 of Act 38-2017.

An original and two copies of the motion for reconsideration shall be filed to the Secretary of the Review Board, and a copy thereof shall be filed with the Bid Board.

The mere presentation of a Request for Reconsideration will not have the effect of halting the contested award. The Bid Review Board may or may not consider the Request for Reconsideration. The terms in relation to this action or lack of action, as well as its Judicial review, if any, shall be those established in Act 38-2017, *supra*.

Sincerely,

William Rios Maldonado, Esq.
Procurement Division Director
CDBG-DR Program

cc:

Mrs. Adalgisa Polanco Reyes
Secretary, Bid Board

I hereby certify that this notice of award was delivered to all Proposers listed in **Exhibit II**.

Receipt Number: 7019 2280 0001 9457 5792

rw

AK

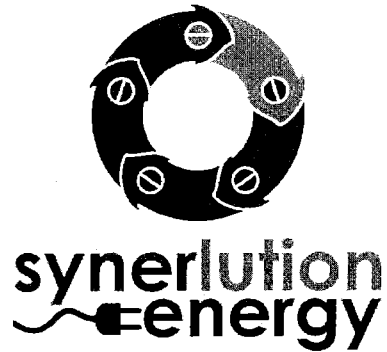

rw

**CDBG-DR-IFB-2021-01
PV Systems, Water
Cisterns Acquisition, and
Installation Services**

Submission Date: April 14, 2021

W

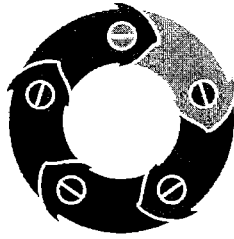

**synerlution
energy**

700

PV System Documentation

U

2221 Militar Ave Suite 103 Isabela, PR 00662 . (787) 493-0864 . (787) 493-0865

Enphase Encharge 10

The **Enphase Encharge 10™** all-in-one AC-coupled storage system is **reliable, smart, simple, and safe**. It is comprised of three base Encharge 3™ storage units, has a total usable energy capacity of 10.08 kWh and twelve embedded grid-forming microinverters with 3.84 kW power rating. It provides backup capability and installers can quickly design the right system size to meet the needs of both new and retrofit solar customers.

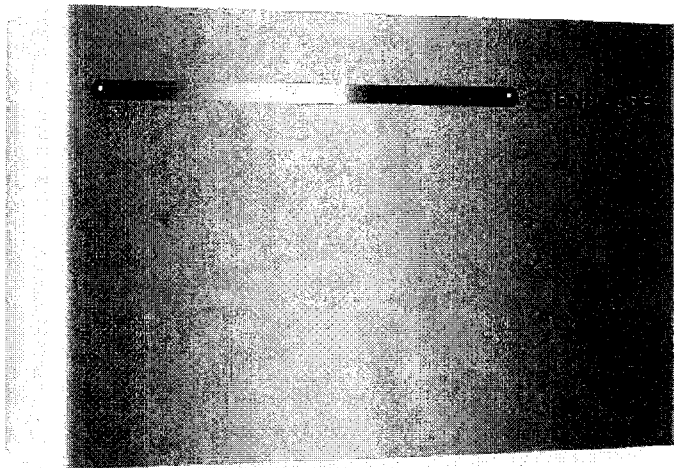

Reliable

- Proven high reliability IQ Series Microinverters
- Ten-year limited warranty
- Three independent Encharge storage base units
- Twelve embedded IQ 8X-BAT Microinverters
- Passive cooling (no moving parts/fans)

Smart

- Grid-forming capability for backup operation
- Remote software and firmware upgrade
- Mobile app-based monitoring and control
- Support for self consumption
- Utility time of use (TOU) optimization

Simple

- Fully integrated AC battery system
- Quick and easy plug-and-play installation
- Interconnects with standard household AC wiring

Safe

- Cells safety tested
- Lithium iron phosphate (LFP) chemistry for maximum safety and longevity

To learn more about Enphase offerings, visit enphase.com



Enphase Encharge 10

MODEL NUMBER	
ENCHARGE-10-1P-NA	Encharge 10 battery storage system with integrated Enphase Microinverters and battery management unit (BMU). Includes: - Three Encharge 3.36 kWh base units (B03-A01-US00-1-3) - One Encharge 10 cover kit with cover, wall mounting bracket, watertight conduit hubs, and interconnect kit for wiring between batteries (B10-C-1050-0)
ACCESSORIES	
ENCHARGE-HNDL-R1	One set of Encharge base unit installation handles
OUTPUT (AC)	
	@ 240 VAC ¹
Rated (continuous) output power	3.84 kVA
Peak output power	5.7 kVA (10 seconds)
Nominal voltage / range	240 / 211 – 264 VAC
Nominal frequency / range	60 / 57 – 61 Hz
Rated output current	16 A
Peak output current	24.6A (10 seconds)
Power factor (adjustable)	0.85 leading ... 0.85 lagging
Maximum units per 20 A branch circuit	1 unit (single phase)
Interconnection	Single-phase
Maximum AC short circuit fault current over 3 cycles	69.6 Arms
Round trip efficiency ²	89%
BATTERY	
Total capacity	10.5 kWh
Usable capacity	10.08 kWh
Round trip efficiency	96%
Nominal DC voltage	67.2 V
Maximum DC voltage	73.5 V
Ambient operating temperature range	-15° C to 55° C (5° F to 131° F) non-condensing
Optimum operating temperature range	0° C to 30° C (32° F to 86° F)
Chemistry	Lithium iron phosphate (LFP)
MECHANICAL DATA	
Dimensions (WxHxD)	1070 mm x 664 mm x 319 mm (42.13 in x 26.14 in x 12.56 in)
Weight	Three individual 44.2 kg (97.4 lbs) base units plus 21.1 kg (48.7 lbs) cover and mounting bracket; total 154.7 kg (341 lbs)
Enclosure	Outdoor – NEMA type 3R
IQ 8X-BAT microinverter enclosure	NEMA type 6
Cooling	Natural convection – No fans
Altitude	Up to 2500 meters (8200 feet)
Mounting	Wall mount
FEATURES AND COMPLIANCE	
Compatibility	Compatible with grid-tied PV systems. Compatible with Enphase M215/M250 and IQ Series Micros, Enphase Enpower, and Enphase IQ Envoy for backup operation.
Communication	Wireless 2.4 GHz
Services	Backup, self-consumption, TOU, Demand Charge, NEM Integrity
Monitoring	Enlighten Manager and MyEnlighten monitoring options; API integration
Compliance	UL 9540, UN 38.3, UL 9540A, UL 1998, UL 991, NEMA Type 3R, AC156 EMI: 47 CFR, Part 15, Class B, ICES 003 Cell Module: UL 1973, UN 38.3 Inverters: UL 62109-1, IEC 62109-2, UL 1741SA, CAN/CSA C22.2 No. 107.1-16, and IEEE 1547
LIMITED WARRANTY	
Limited Warranty ³	>70% capacity, up to 10 years or 4000 cycles
<ol style="list-style-type: none"> Supported in backup/off grid operations AC to Battery to AC at 50% power rating. Whichever occurs first. Restrictions apply. 	

To learn more about Enphase offerings, visit enphase.com

© 2021 Enphase Energy. All rights reserved. Enphase, the Enphase logo, Encharge 10, and other trademarks or service names are the trademarks of Enphase Energy, Inc. Data subject to change. 2021-03-01



Enphase Encharge 3

The **Enphase Encharge 3™** all-in-one AC-coupled storage system is **reliable, smart, simple, and safe**. It has a total usable energy capacity of 3.36 kWh and includes four embedded grid-forming microinverters with 1.28 kW power rating. It provides backup capability and installers can quickly design the right system size to meet the needs of both new and retrofit solar customers.

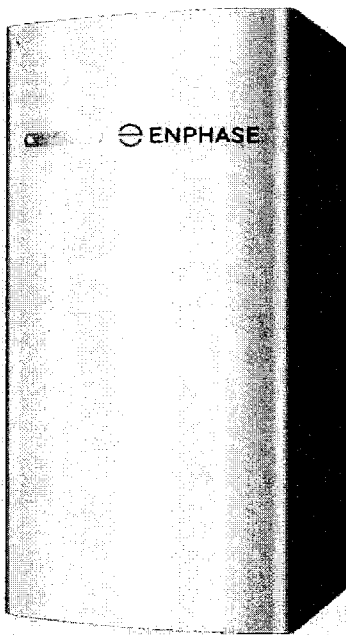

Reliable

- Proven high-reliability IQ Series Microinverters
- Ten-year limited warranty
- Four embedded IQ 8X-BAT Microinverters
- Passive cooling (no moving parts/fans)

Smart

- Grid-forming capability for backup operation
- Remote software and firmware upgrade
- Mobile app-based monitoring and control
- Support for self consumption
- Utility time of use (TOU) optimization

Simple

- Fully integrated AC battery system
- Quick and easy plug-and-play installation
- Interconnects with standard household AC wiring

Safe

- Battery safety tested
- Lithium iron phosphate (LFP) chemistry for maximum safety and longevity

To learn more about Enphase offerings, visit enphase.com



Enphase Encharge 3

MODEL NUMBER	
ENCHARGE-3-1P-NA	Encharge 3 battery storage system with integrated Enphase Microinverters and battery management unit (BMU). Includes: - One Encharge 3.36 kWh base unit (B03-A01-US00-1-3) - One Encharge 3 cover kit with cover and wall mounting bracket (B03-C-0350-0)
ACCESSORIES	
ENCHARGE-HNDL-R1	One set of Encharge base unit installation handles
OUTPUT (AC)	
	@240 VAC ¹
Rated (continuous) output power	1.28 kVA
Peak output power	1.92 kVA (10 seconds)
Nominal voltage / range	240/211–264 VAC
Nominal frequency / range	60/57–63 Hz
Rated output current	5.3 A
Peak output current	8.2A (10 seconds)
Power factor (adjustable)	0.85 leading ... 0.85 lagging
Maximum units per 20 A branch circuit	Three units (single phase)
Interconnection	Single phase
Maximum AC short circuit fault current over 3 cycles	23.2 Arms
Round trip efficiency ²	89%
BATTERY	
Total capacity	3.5 kWh
Usable capacity	3.36 kWh
Round trip efficiency	96%
Nominal DC voltage	67.2 V
Maximum DC voltage	73.5 V
Ambient operating temperature range	-15° C to 55° C (5° F to 131° F) non-condensing
Optimum operating temperature range	0° C to 30° C (32° F to 86° F)
Chemistry	Lithium iron phosphate (LFP)
MECHANICAL DATA	
Dimensions (WxHxD)	367 mm x 664 mm x 319mm (14.45 in x 26.14 in x 12.56 in)
Weight	One individual 44.2 kg (97.4 lbs) base unit plus 7.8 kg (17.2 lbs) cover and mounting bracket; total 52 kg (114.6 lbs)
Enclosure	Outdoor – NEMA 3R
IQ 8X-BAT microinverter enclosure	NEMA type 6
Cooling	Natural convection – No fans
Altitude	Up to 2500 meters (8200 feet)
Mounting	Wall mount
FEATURES AND COMPLIANCE	
Compatibility	Compatible with grid-tied PV systems. Compatible with Enphase IQ Series Micros, Enphase Enpower, and Enphase IQ Envoy for backup operation.
Communication	Wireless 2.4 GHz
Services	Backup, self-consumption, TOU, Demand Charge, NEM Integrity
Monitoring	Enlighten Manager and MyEnlighten monitoring options; API integration
Compliance	UL 9540, UN 38.3, UL 9540A, UL 1998, UL 991, NEMA Type 3R, AC156 EMI: 47 CFR, Part 15, Class B, ICES 003 Cell Module: UL 1973, UN 38.3 Inverters: UL 62109-1, IEC 62109-2, UL 1741SA, CAN/CSA C22.2 No. 107.1-16, IEEE 1547
LIMITED WARRANTY	
Limited Warranty ³	>70% capacity, up to 10 years or 4000 cycles
<ol style="list-style-type: none"> Supported in backup/off-grid operation. AC to battery to AC at 50% power rating. Whichever occurs first. Restrictions apply. 	

To learn more about Enphase offerings, visit enphase.com

© 2020 Enphase Energy. All rights reserved. Enphase, the Enphase logo, Encharge 10, and other trademarks or service names are the trademarks of Enphase Energy, Inc. Data subject to change. 2020-11-23



Enphase Enpower

The **Enphase Enpower™** smart switch connects the home to grid power, the Encharge storage system, and solar PV. It provides microgrid interconnection device (MID) functionality by automatically detecting and seamlessly transitioning the home energy system from grid power to backup power in the event of a grid failure. It consolidates interconnection equipment into a single enclosure and streamlines grid independent capabilities of PV and storage installations by providing a consistent, pre-wired solution for residential applications.

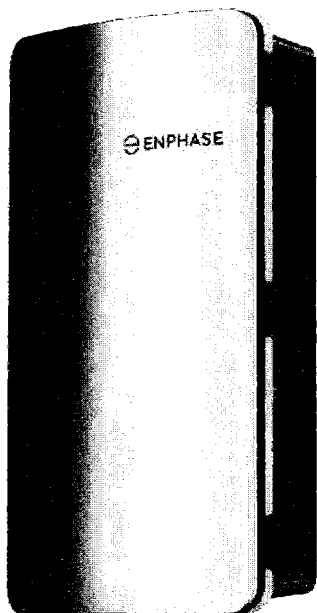

Reliable

- Durable NEMA type 3R enclosure
- Ten-year limited warranty

Smart

- Controls safe connectivity to the grid
- Automatically detects grid outages
- Provides seamless transition to backup

Simple

- Connects to the load or service equipment¹ side of the main load panel
- Centered mounting brackets support single stud mounting
- Supports conduit entry from the bottom, bottom left side, and bottom right side
- Supports whole home and partial home backup and subpanel backup
- Up to 200A main breaker support
- Includes neutral-forming transformer for split phase 120/240V backup operation

1. Enpower is not suitable for use as service equipment in Canada.

To learn more about Enphase offerings, visit enphase.com



Enphase Enpower

MODEL NUMBER

EP200G101-M240US00

Enphase Enpower smart switch with neutral-forming transformer (NFT), Microgrid Interconnect Device (MID), breakers, and screws. Streamlines grid-independent capabilities of PV and storage installations.

ACCESSORIES and REPLACEMENT PARTS

XA-E3-PCBA-ENS	Replacement Enpower controller printed circuit board
EP200G-NA-HD-200A	Eaton type BR circuit breaker hold-down screw kit, BRHDK125
EP200G-HNDL-R1	Enpower installation handle kit (order separately)
Circuit breakers (as needed) ^{2, 3}	Not included, must order separately:
BRK-100A-2P-240V	• Main breaker, 2 pole, 100A, 25kAIC, CSR2100
BRK-125A-2P-240V	• Main breaker, 2 pole, 125A, 25kAIC, CSR2125N
BRK-150A-2P-240V	• Main breaker, 2 pole, 150A, 25kAIC, CSR2150N
BRK-175A-2P-240V	• Main breaker, 2 pole, 175A, 25kAIC, CSR2175N
BRK-200A-2P-240V	• Main breaker, 2 pole, 200A, 25kAIC, CSR2200N
BRK-20A-2P-240V-B	• Circuit breaker, 2 pole, 20A, 10kAIC, BR220B
BRK-30A-2P-240V	• Circuit breaker, 2 pole, 30A, 10kAIC, BR230B
BRK-40A-2P-240V	• Circuit breaker, 2 pole, 40A, 10kAIC, BR240B
BRK-60A-2P-240V	• Circuit breaker, 2 pole, 60A, 10kAIC, BR260
BRK-80A-2P-240V	• Circuit breaker, 2 pole, 80A, 10kAIC, BR280

ELECTRICAL SPECIFICATIONS

Assembly rating	Continuous operation at 100% of its rating
Nominal voltage / range (L-L)	240 VAC / 100 - 310 VAC
Voltage measurement accuracy	±1% V nominal (±1.2V L-N and ±2.4V L-L)
Auxiliary contact for load control and excess PV control	24V, 1A
Nominal frequency / range	60 Hz / 56 - 63 Hz
Frequency measurement accuracy	±0.1 Hz
Maximum continuous current rating	160A
Maximum input overcurrent protection device	200A
Maximum output overcurrent protection device	200A
Maximum overcurrent protection device rating for storage branch circuit ⁴	80A
Maximum overcurrent protection device rating for PV combiner branch circuit ⁴	80A
Neutral Forming Transformer (NFT)	<ul style="list-style-type: none"> • Breaker rating (pre-installed): 40A between L1 and Neutral; 40A between L2 and Neutral • Continuous rated power: 3600VA • Maximum continuous unbalance current: 30A @ 120V • Peak rated power: 8800VA for 30 seconds • Peak unbalanced current: 80A @ 120V for 30 seconds

MECHANICAL DATA

Dimensions (WxHxD)	50cm x 91.6cm x 24.6cm (19.7 in x 36 in x 9.7 in)
Weight	38.5 kg (85 lbs)
Ambient temperature range	-40° C to +50° C (-40° F to 122° F)
Cooling	Natural convection, plus heat shield
Enclosure environmental rating	Outdoor, NEMA type 3R, polycarbonate construction
Altitude	To 2500 meters (8200 feet)

WIRE SIZES

Connections (All lugs are rated to 90C)	<ul style="list-style-type: none"> • Main lugs and backup load lugs • CSR breakers • BR breakers (wire provided) • AC combiner lugs, Encharge lugs, and generator lugs • Neutral (large lugs) 	Cu/Al: 1 AWG - 300 KCMIL Cu/Al: 2 AWG - 300 KCMIL 6 AWG 14 AWG - 2 AWG Cu/Al: 6 AWG - 300 KCMIL
Neutral and ground bars	Large holes (5/16-24 UNF) Small holes (10-32 UNF)	14 AWG - 1/0 AWG 14 AWG - 6 AWG

COMPLIANCE

Compliance	UL 1741, UL 1741 SA, UL 1741 PCS, UL1998, UL869A ⁵ , UL67 ⁵ , UL508 ⁵ , UL50E ⁵ , CSA 22.2 No. 107.1, 47 CFR, Part 15, Class B, ICES 003, AC156.
------------	--

2. Compatible with BRHDK125 Hold-Down Kit to comply with 2017 NEC 710.15E for back-fed circuit breakers.
3. The Enpower is rated 22 kAIC
4. Not included. Installer must provide properly rated breaker per circuit breaker list above.
5. Sections from these standards were used during the safety evaluation and included in the UL 1741 listing.

To learn more about Enphase offerings, visit enphase.com

© 2021 Enphase Energy. All rights reserved. Enphase, the Enphase logo, Enpower, and other trademarks or service names are the trademarks of Enphase Energy, Inc. Data subject to change. 2021-01-25



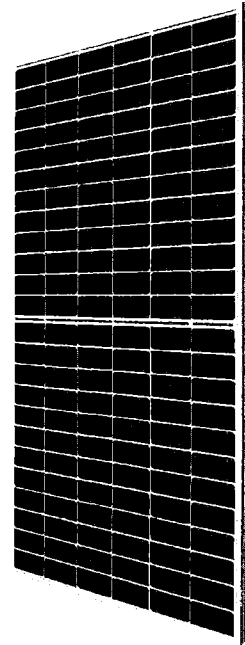

HiKu

SUPER HIGH POWER MONO PERC MODULE

430 W ~ 455 W

CS3W-430 | 435 | 440 | 445 | 450 | 455MS (IEC1000 V)

CS3W-430 | 435 | 440 | 445 | 450 | 455MS (IEC1500 V)

MORE POWER



26 % more power than conventional modules



Up to 4.5 % lower LCOE
Up to 2.7 % lower system cost



Low NMOT: 42 ± 3 °C
Low temperature coefficient (Pmax):
-0.35 % / °C



Better shading tolerance

MORE RELIABLE



Lower internal current,
lower hot spot temperature



Minimizes micro-crack impacts



Heavy snow load up to 5400 Pa,
wind load up to 3600 Pa*



linear power output warranty*



enhanced product warranty on materials and workmanship*

*According to the applicable Canadian Solar Limited Warranty Statement.

MANAGEMENT SYSTEM CERTIFICATES*

ISO 9001:2015 / Quality management system
ISO 14001:2015 / Standards for environmental management system
OHSAS 18001:2007 / International standards for occupational health & safety

PRODUCT CERTIFICATES*

IEC 61215 / IEC 61730: VDE / CE / MCS / INMETRO
UL 1703: CSA / IEC 61701 ED2: VDE / IEC 62716: VDE / IEC 60068-2-68: SGS
UNI 9177 Reaction to Fire: Class 1 / Take-e-way
Canadian Solar recycles panels at the end of life cycle



* As there are different certification requirements in different markets, please contact your local Canadian Solar sales representative for the specific certificates applicable to the products in the region in which the products are to be used.

CANADIAN SOLAR INC. is committed to providing high quality solar products, solar system solutions and services to customers around the world. No. 1 module supplier for quality and performance/price ratio in IHS Module Customer Insight Survey. As a leading PV project developer and manufacturer of solar modules with over 40 GW deployed around the world since 2001.

* For detail information, please refer to Installation Manual.

CANADIAN SOLAR INC.

Canadian Solar MSS (Australia) Pty Ltd., 44 Stephenson St, Cremorne VIC 3121, Australia
sales.au@canadiansolar.com, www.canadiansolar.com/au

ENGINEERING DRAWING (mm)

Rear View

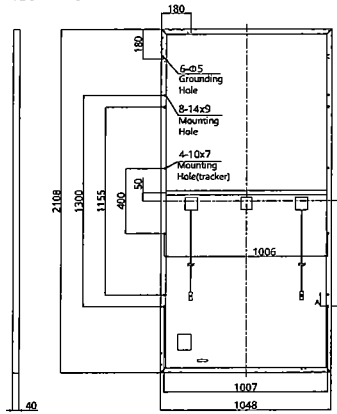

Frame Cross Section A-A

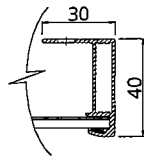

Mounting Hole

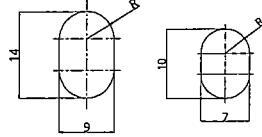

CS3W-435MS / I-V CURVES

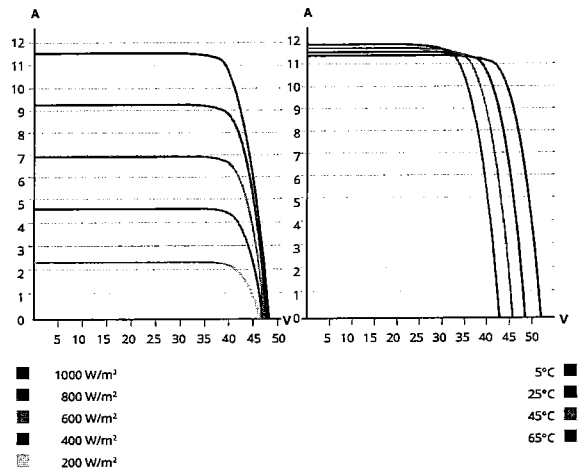

ELECTRICAL DATA | STC*

CS3W	430MS	435MS	440MS	445MS	450MS	455MS
Nominal Max. Power (Pmax)	430 W	435 W	440 W	445 W	450 W	455 W
Opt. Operating Voltage (Vmp)	40.3 V	40.5 V	40.7 V	40.9 V	41.1 V	41.3 V
Opt. Operating Current (Imp)	10.68 A	10.75 A	10.82 A	10.89 A	10.96 A	11.02 A
Open Circuit Voltage (Voc)	48.3 V	48.5 V	48.7 V	48.9 V	49.1 V	49.3 V
Short Circuit Current (Isc)	11.37 A	11.42 A	11.48 A	11.54 A	11.60 A	11.66 A
Module Efficiency	19.5%	19.7%	19.9%	20.1%	20.4%	20.6%
Operating Temperature	-40°C ~ +85°C					
Max. System Voltage	1500V (IEC/UL) or 1000V (IEC/UL)					
Module Fire Performance	TYPE 1 (UL 1703) or CLASS C (IEC 61730)					
Max. Series Fuse Rating	20 A					
Application Classification	Class A					
Power Tolerance	0 ~ + 5 W					

* Under Standard Test Conditions (STC) of irradiance of 1000 W/m², spectrum AM 1.5 and cell temperature of 25°C. Measurement uncertainty: ±3% (Pmax).

ELECTRICAL DATA | NMOT*

CS3W	430MS	435MS	440MS	445MS	450MS	455MS
Nominal Max. Power (Pmax)	321 W	325 W	328 W	332 W	336 W	339 W
Opt. Operating Voltage (Vmp)	37.6 V	37.8 V	37.9 V	38.1 V	38.3 V	38.5 V
Opt. Operating Current (Imp)	8.54 A	8.59 A	8.65 A	8.71 A	8.76 A	8.82 A
Open Circuit Voltage (Voc)	45.4 V	45.6 V	45.8 V	46.0 V	46.2 V	46.4 V
Short Circuit Current (Isc)	9.17 A	9.21 A	9.26 A	9.31 A	9.36 A	9.41 A

* Under Nominal Module Operating Temperature (NMOT), irradiance of 800 W/m² spectrum AM 1.5, ambient temperature 20°C, wind speed 1 m/s.

MECHANICAL DATA

Specification	Data
Cell Type	Mono-crystalline
Cell Arrangement	144 [2 X (12 X 6)]
Dimensions	2108 X 1048 X 40 mm (83.0 X 41.3 X 1.57 in)
Weight	24.9 kg (54.9 lbs)
Front Cover	3.2 mm tempered glass
Frame	Anodized aluminium alloy, crossbar enhanced
J-Box	IP68, 3 bypass diodes
Cable	4 mm ² (IEC), 12 AWG (UL)
Cable Length (Including Connector)	Portrait: 500 mm (19.7 in) (+) / 350 mm (13.8 in) (-); landscape: 1400 mm (55.1 in); leap-frog connection: 1670 mm (65.7 in)*
Connector	T4-PC-1 (IEC 1000 V) or PV-KST4/xy-UR, PV-KBT4/xy-UR (IEC 1000 V) or T4-PC-1 (IEC 1500 V) or T4-PPE-1 (IEC 1500 V) or PV-KST4-EVO2/XY, PV-KBT4-EVO2/XY (IEC 1500 V) or UTXCFA4AM, UTXCMA4AM (IEC 1500 V)
Per Pallet	27 pieces
Per Container (40' HQ)	594 pieces

* For detailed information, please contact your local Canadian Solar sales and technical representatives.

TEMPERATURE CHARACTERISTICS

Specification	Data
Temperature Coefficient (Pmax)	-0.35 % / °C
Temperature Coefficient (Voc)	-0.27 % / °C
Temperature Coefficient (Isc)	0.05 % / °C
Nominal Module Operating Temperature	42 ± 3°C

PARTNER SECTION

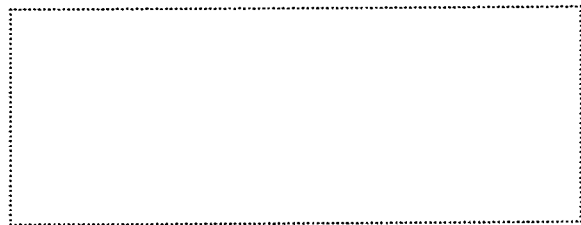

CANADIAN SOLAR INC.

Canadian Solar MSS (Australia) Pty Ltd., 44 Stephenson St, Cremorne VIC 3121, Australia
 sales.au@canadiansolar.com, www.canadiansolar.com/au

Enphase IQ 7A Microinverter

7A

The high-powered smart grid-ready **Enphase IQ 7A Micro™** dramatically simplifies the installation process while achieving the highest system efficiency for systems with 60-cell and 72-cell modules.

Part of the Enphase IQ System, the IQ 7A Micro integrates with the Enphase IQ Envoy™, Enphase IQ Battery™, and the Enphase Enlighten™ monitoring and analysis software.

The IQ Series Microinverters extend the reliability standards set forth by previous generations and undergo over a million hours of power-on testing, enabling Enphase to provide an industry-leading warranty of up to 25 years.

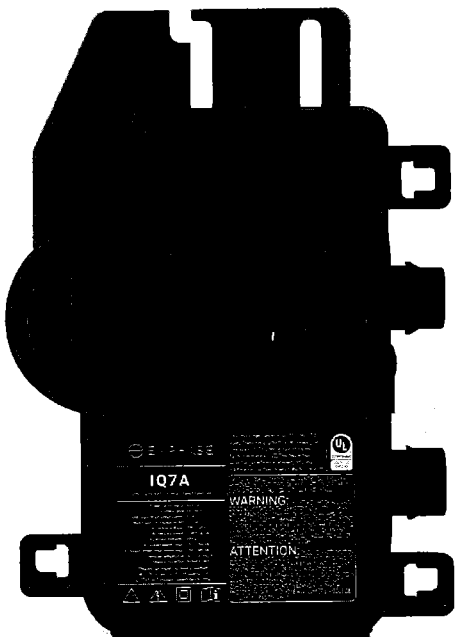

UM

High Power

- Peak output power 366 VA @ 240 VAC and 295 VA @ 208 VAC

Easy to Install

- Lightweight and simple
- Faster installation with improved, lighter two-wire cabling
- Built-in rapid shutdown compliant (NEC 2014 & 2017)

Efficient and Reliable

- Optimized for high powered 60-cell and 72-cell modules
- Highest CEC efficiency of 97%
- More than a million hours of testing
- Class II double-insulated enclosure
- UL listed

Smart Grid Ready

- Complies with advanced grid support, voltage and frequency ride-through requirements
- Envoy and Internet connection required
- Configurable for varying grid profiles
- Meets CA Rule 21 (UL 1741-SA)



To learn more about Enphase offerings, visit enphase.com



Enphase IQ 7A Microinverter

INPUT (DC)		IQ7A-72-2-US	
Commonly used module pairings ¹	295 W–460 W +		
Module compatibility	60-cell, 66-cell, and 72-cell PV modules		
Maximum input DC voltage	58 V		
Power point tracking voltage range ²	18 V–58 V		
Min/Max start voltage	33 V / 58 V		
Max DC short circuit current (module I _{sc}) ³	15 A		
Overvoltage class DC port	II		
DC port backfeed current	0 A		
PV array configuration	1 x 1 ungrounded array; No additional DC side protection required; AC side protection requires max 20A per branch circuit		
OUTPUT (AC)		@ 240 VAC	@ 208 VAC
Peak output power	366 VA	295 VA	
Maximum continuous output power	349 VA	290 VA	
Nominal (L-L) voltage/range ⁴	240 V / 211–264 V	208 V / 183–229 V	
Maximum continuous output current	1.45 A (240 VAC)	1.39 A (208 VAC)	
Nominal frequency	60 Hz		
Extended frequency range	47–68 Hz		
AC short circuit fault current over 3 cycles	5.8 Arms		
Maximum units per 20 A (L-L) branch circuit ⁵	11 (240 VAC)	11 (208 VAC)	
Overvoltage class AC port	III		
AC port backfeed current	18 mA		
Power factor setting	1.0		
Power factor (adjustable)	0.85 leading ... 0.85 lagging		
EFFICIENCY		@240 VAC	@208 VAC
CEC weighted efficiency	97.0 %		96.5%
MECHANICAL			
Ambient temperature range	-40°C to +60°C		
Relative humidity range	4% to 100% (condensing)		
Connector type: DC (IQ7A-72-2-US)	MC4		
Dimensions (HxWxD)	212 mm x 175 mm x 30.2 mm (without bracket)		
Weight	1.08 kg (2.38 lbs)		
Cooling	Natural convection – No fans		
Approved for wet locations	Yes		
Pollution degree	PD3		
Enclosure	Class II double-insulated, corrosion resistant polymeric enclosure		
Environmental category / UV exposure rating	NEMA Type 6 / outdoor		
FEATURES			
Communication	Power Line Communication (PLC)		
Monitoring	Enlighten Manager and MyEnlighten monitoring options Compatible with Enphase IQ Envoy		
Disconnecting means	The AC and DC connectors have been evaluated and approved by UL for use as the load-break disconnect required by NEC 690.		
Compliance	CA Rule 21 (UL 1741-SA) UL 62109-1, UL1741/IEEE1547, FCC Part 15 Class B, ICES-0003 Class B, CAN/CSA-C22.2 NO. 107.1-01 This product is UL Listed as PV Rapid Shut Down Equipment and conforms with NEC-2014 and NEC-2017 section 690.12 and C22.1-2015 Rule 64-218 Rapid Shutdown of PV Systems, for AC and DC conductors, when installed according manufacturer's instructions.		

1. No enforced DC/AC ratio. See the compatibility calculator at <https://enphase.com/en-us/support/module-compatibility>.
2. CEC peak power tracking voltage range is 38 V to 43 V.
3. Maximum continuous input DC current is 10.2A.
4. Voltage range can be extended beyond nominal if required by the utility.
5. Limits may vary. Refer to local requirements to define the number of microinverters per branch in your area.

To learn more about Enphase offerings, visit enphase.com

© 2020 Enphase Energy. All rights reserved. Enphase, the Enphase logo, Enphase IQ 7A, Enphase IQ Battery, Enphase Enlighten, Enphase IQ Envoy, and other trademarks or service names are the trademarks of Enphase Energy, Inc. Data subject to change.
2020-06-16



Enphase IQ Combiner 3-ES/3C-ES

X-IQ-AM1-240-3-ES
X-IQ-AM1-240-3C-ES

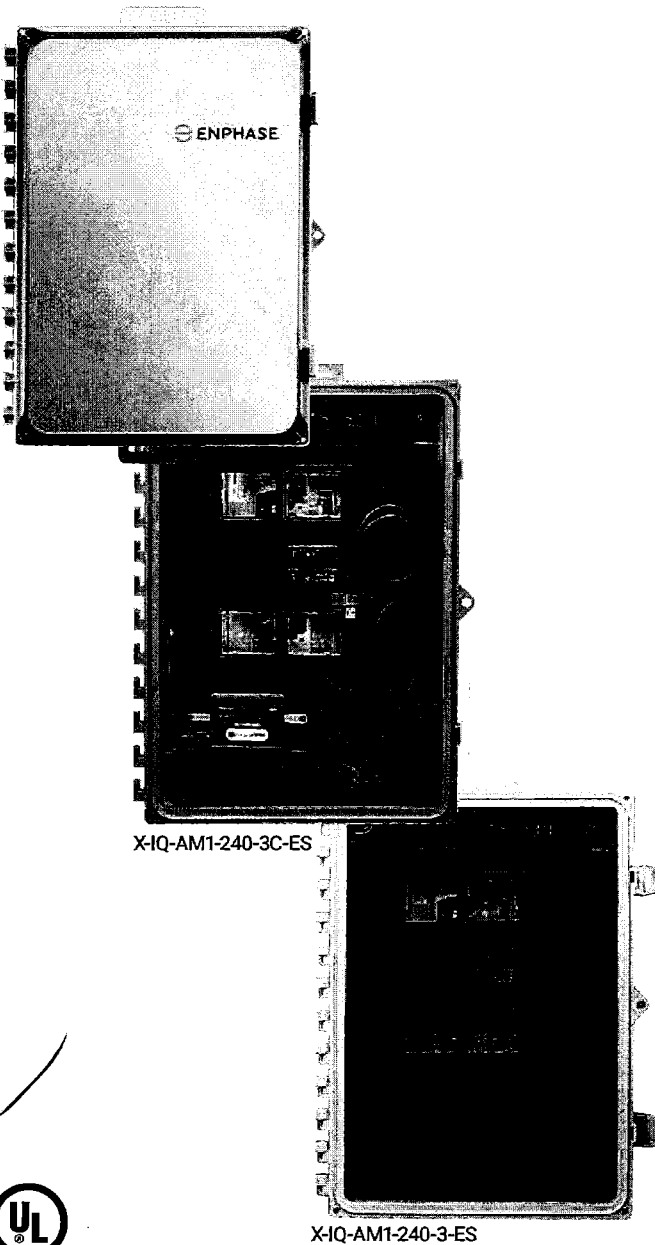

The **Enphase IQ Combiner 3-ES/3C-ES™** with Enphase IQ Envoy™ and integrated LTE-M1 cell modem (included only with IQ Combiner 3C-ES) consolidates interconnection equipment into a single enclosure and streamlines PV and storage installations by providing a consistent, pre-wired solution for residential applications. It offers up to four 2-pole input circuits and Eaton BR series busbar assembly.

Smart

- Includes IQ Envoy for communication and control
- Includes LTE-M1 cell modem (included only with IQ Combiner 3C-ES)
- Includes solar shield to match Ensemble esthetics and deflect heat
- Flexible networking supports Wi-Fi, Ethernet, or cellular
- Optional AC receptacle available for PLC bridge
- Provides production metering and consumption monitoring

Simple

- Reduced size from IQ Combiner+ (X-IQ-AM1-240-2)
- Centered mounting brackets support single stud mounting
- Supports back and side conduit entry
- Up to four 2-pole branch circuits for 240 VAC plug-in breakers (not included)
- 80 A total PV or storage branch circuits

Reliable

- Durable NRTL-certified NEMA type 3R enclosure
- Five-year limited warranty
- Two years labor reimbursement program coverage included
- UL listed



To learn more about Enphase offerings, visit enphase.com



Enphase IQ Combiner 3-ES / 3C-ES

MODEL NUMBER	
IQ Combiner 3-ES (X-IQ-AM1-240-3-ES)	IQ Combiner 3-ES with Enphase IQ Envoy printed circuit board for integrated revenue grade PV production metering (ANSI C12.20 +/- 0.5%) and consumption monitoring (+/- 2.5%). Includes a silver solar shield to match the Encharge storage system and Enpower smart switch and to deflect heat.
IQ Combiner 3C-ES (X-IQ-AM1-240-3C-ES)	IQ Combiner 3C-ES with Enphase IQ Envoy printed circuit board for integrated revenue grade PV production metering (ANSI C12.20 +/- 0.5%) and consumption monitoring (+/- 2.5%). Includes Enphase Mobile Connect LTE-M1 (CELLMODEM-M1), a plug-and-play industrial-grade cell modem for systems up to 60 microinverters. (Available in the US, Canada, Mexico, Puerto Rico, and the US Virgin Islands, where there is adequate cellular service in the installation area.) Includes a silver solar shield to match the Encharge storage system and Enpower smart switch and to deflect heat.
ACCESSORIES and REPLACEMENT PARTS	
	(not included, order separately)
Ensemble Communications Kit (COMMS-CELLMODEM-M1)	Includes COMMS-KIT-01 and CELLMODEM-M1 with 5-year data plan for Ensemble sites
Circuit Breakers BRK-10A-2-240 BRK-15A-2-240 BRK-20A-2P-240	Supports Eaton BR210, BR215, BR220, BR230, BR240, BR250, and BR260 circuit breakers. Circuit breaker, 2 pole, 10A, Eaton BR210 Circuit breaker, 2 pole, 15A, Eaton BR215 Circuit breaker, 2 pole, 20A, Eaton BR220
EPLC-01	Power line carrier (communication bridge pair), quantity - one pair
XA-SOLARSHIELD-ES	Replacement solar shield for Combiner 3-ES / 3C-ES
XA-PLUG-120-3	Accessory receptacle for Power Line Carrier in IQ Combiner 3-ES / 3C-ES (required for EPLC-01)
XA-ENV-PCBA-3	Replacement IQ Envoy printed circuit board (PCB) for Combiner 3-ES / 3C-ES
ELECTRICAL SPECIFICATIONS	
Rating	Continuous duty
System voltage	120/240 VAC, 60 Hz
Eaton BR series busbar rating	125 A
Max. continuous current rating	65 A
Max. continuous current rating (input from PV/storage)	64 A
Max. fuse/circuit rating (output)	90 A
Branch circuits (solar and/or storage)	Up to four 2-pole Eaton BR series Distributed Generation (DG) breakers only (not included)
Max. total branch circuit breaker rating (input)	80A of distributed generation / 90A with IQ Envoy breaker included
Production metering CT	200 A solid core pre-installed and wired to IQ Envoy
Consumption monitoring CT (CT-200-SPLIT)	A pair of 200 A split core current transformers
MECHANICAL DATA	
Dimensions (WxHxD)	37.5 x 49.5 x 16.8 cm (14.75" x 19.5" x 6.63"). Height is 21.06" (53.5 cm) with mounting brackets.
Weight	7.5 kg (16.5 lbs)
Ambient temperature range	-40° C to +46° C (-40° to 115° F)
Cooling	Natural convection, plus heat shield
Enclosure environmental rating	Outdoor, NRTL-certified, NEMA type 3R, polycarbonate construction
Wire sizes	<ul style="list-style-type: none"> • 20 A to 50 A breaker inputs: 14 to 4 AWG copper conductors • 60 A breaker branch input: 4 to 1/0 AWG copper conductors • Main lug combined output: 10 to 2/0 AWG copper conductors • Neutral and ground: 14 to 1/0 copper conductors Always follow local code requirements for conductor sizing.
Altitude	To 2000 meters (6,560 feet)
INTERNET CONNECTION OPTIONS	
Integrated Wi-Fi	802.11b/g/n
Cellular	CELLMODEM-M1 4G based LTE-M1 cellular modem (included only with IQ Combiner 3C-ES). Note that an Enphase Mobile Connect cellular modem is required for all Ensemble installations.
Ethernet	Optional, 802.3, Cat5E (or Cat 6) UTP Ethernet cable (not included)
COMPLIANCE	
Compliance, Combiner	UL 1741, CAN/CSA C22.2 No. 107.1, 47 CFR, Part 15, Class B, ICES 003 Production metering: ANSI C12.20 accuracy class 0.5 (PV production) Consumption metering: accuracy class 2.5
Compliance, IQ Envoy	UL 60601-1/CANCSA 22.2 No. 61010-1

To learn more about Enphase offerings, visit enphase.com

© 2020 Enphase Energy. All rights reserved. Enphase, the Enphase logo, IQ Combiner 3C-ES, and other trademarks or service names are trademarks of Enphase Energy, Inc. Data subject to change. 2020-10-01



Enphase Q Cable Accessories

The **Enphase Q Cable™** and accessories are part of the latest generation Enphase IQ System™. These accessories provide simplicity, reliability, and faster installation times.

76



Enphase Q Cable

- Two-wire, double-insulated Enphase Q Cable is 50% lighter than the previous generation Enphase cable
- New cable numbering and plug and play connectors speed up installation and simplify wire management
- Link connectors eliminate cable waste

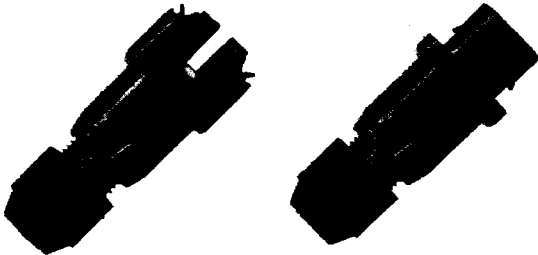

Field-Wireable Connectors

- Easily connect Q cables on the roof without complex wiring
- Make connections from any open connector and center feed any section of cable within branch limits
- Available in male and female connector types

11

To learn more about Enphase offerings, visit enphase.com







Enphase Q Cable Accessories

CONDUCTOR SPECIFICATIONS	
Certification	UL3003 (raw cable), UL 9703 (cable assemblies), DG cable
Flame test rating	FT4
Compliance	RoHS, OIL RES I, CE, UV Resistant, combined UL for Canada and United States
Conductor type	THHN/THWN-2 dry/wet
Disconnecting means	The AC and DC bulkhead connectors have been evaluated and approved by UL for use as the load-break disconnect required by NEC 690.

Q CABLE TYPES / ORDERING OPTIONS				
Connectorized Models	Size / Max Nominal Voltage	Connector Spacing	PV Module Orientation	Connector Count per Box
Q-12-10-240	12 AWG / 277 VAC	1.3 m (4.2 ft)	Portrait	240
Q-12-17-240	12 AWG / 277 VAC	2.0 m (6.5 ft)	Landscape (60-cell)	240
Q-12-20-200	12 AWG / 277 VAC	2.3 m (7.5 ft)	Landscape (72-cell)	200

ENPHASE Q CABLE ACCESSORIES		
Name	Model Number	Description
Raw Q Cable	Q-12-RAW-300	300 meters of 12 AWG cable with no connectors
Field-wireable connector (male)	Q-CONN-10M	Make connections from any open connector
Field-wireable connector (female)	Q-CONN-10F	Make connections from any Q Cable open connector
Cable Clip	Q-CLIP-100	Used to fasten cabling to the racking or to secure looped cabling
Disconnect tool	Q-DISC-10	Disconnect tool for Q Cable connectors, DC connectors, and AC module mount
Q Cable sealing caps (female)	Q-SEAL-10	One needed to cover each unused connector on the cabling
Terminator	Q-TERM-10	Terminator cap for unused cable ends
Enphase EN4 to MC4 adaptor ¹	ECA-EN4-S22	Connect PV module using MC4 connectors to IQ micros with EN4 (TE PV4-S SOLARLOK). 150mm/5.9" to MC4.
Enphase EN4 non-terminated adaptor ¹	ECA-EN4-FW	For field wiring of UL certified DC connectors. EN4 (TE PV4-S SOLARLOK) to non-terminated cable. 150mm/5.9"
Enphase EN4 to MC4 adaptor (long) ¹	ECA-EN4-S22-L	Longer adapter cable for EN4 (TE PV4-S SOLARLOK) to MC4. Use with split cell modules or PV modules with short DC cable. 600mm/23.6"
Replacement DC Adaptor (MC4)	Q-DCC-2	DC adaptor to MC4 (max voltage 100 VDC)
Replacement DC Adaptor (UTX)	Q-DCC-5	DC adaptor to UTX (max voltage 100 VDC)

1. Qualified per UL subject 9703.

 <p>TERMINATOR Terminator cap for unused cable ends, sold in packs of ten (Q-TERM-10)</p>		 <p>SEALING CAPS Sealing caps for unused aggregator and cable connections (Q-BA-CAP-10 and Q-SEAL-10)</p>
 <p>DISCONNECT TOOL Plan to use at least one per installation, sold in packs of ten (Q-DISC-10)</p>		 <p>CABLE CLIP Used to fasten cabling to the racking or to secure looped cabling, sold in packs of one hundred (Q-CLIP-100)</p>

To learn more about Enphase offerings, visit enphase.com

© 2020 Enphase Energy. All rights reserved. Enphase, the Enphase logo, Enphase IQ 7A, Enphase IQ Battery, Enphase Enlighten, Enphase IQ Envoy, and other trademarks or service names are the trademarks of Enphase Energy, Inc. Data subject to change.
2020-06-26



Plug-and-play cellular monitoring

The Enphase **Mobile Connect** cellular modems deliver easy, reliable networking for Enphase Systems - with three plans to meet your needs.

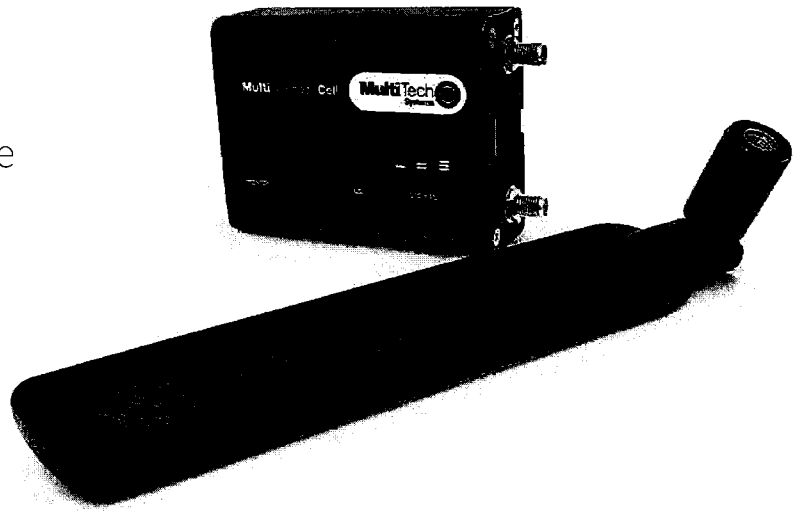

700

Mobile Connect Options

SKU: CELLMODEM-01

- 3G Coverage
- 5-year pre-paid AT&T data plan
- 5-year equipment warranty
- Up to 60 microinverters

SKU: CELLMODEM-M1

- LTE-M coverage
- 5-year pre-paid AT&T data plan
- 5-year equipment warranty
- Up to 60 microinverters
- Requires Envoy software 4.10.XX or later

SKU: CELLMODEM-03

- 3G and 4G LTE Coverage
- 12-year pre-paid AT&T data plan
- 5-year equipment warranty
- Up to 60 microinverters



Mobile Connect is provided by AT&T and available in the US, Puerto Rico, US Virgin Islands, Canada and Mexico. Visit ATT.com for a detailed coverage map.

No Internet? No problem!

Enphase's pre-configured cellular modem plugs into the Envoy-S or IQ-Envoy USB port for one-minute set up.

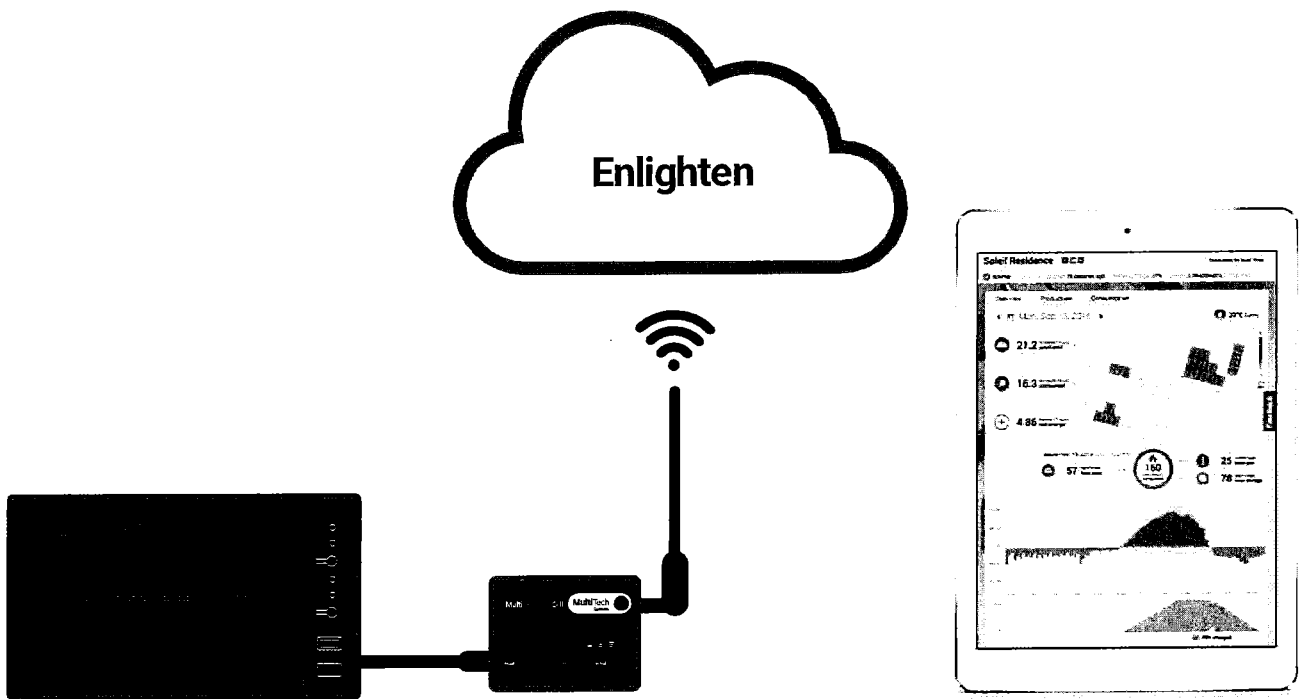

1. The Envoy-S or IQ Envoy stores 15-minute, microinverter, meter and Enphase Battery performance data.
2. Mobile Connect reports 15-minute data to Enlighten four times a day.
3. Historical performance is presented in both Enlighten Manager and MyEnlighten.

For more information, contact your Enphase authorized distributor.



1/4" BOLT LOCATION

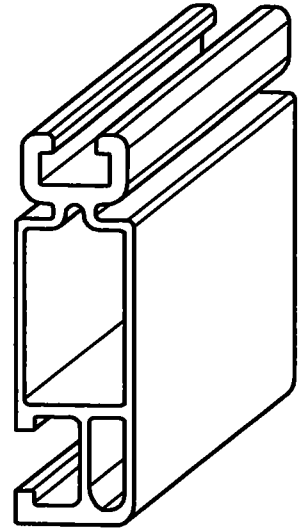
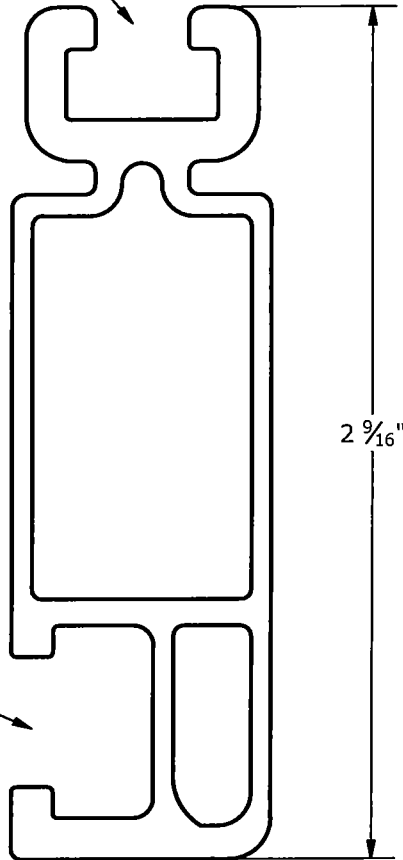

700

PART # TABLE

P/N	DESCRIPTION	LENGTH
320132M	SM RAIL 132" MILL	132"
310132C	SM RAIL 132" CLR	132"
320168M	SM RAIL 168" MILL	168"
310168C	SM RAIL 168" CLR	168"
320168D	SM RAIL 168" DRK	168"
320208M	SM RAIL 208" MILL	208"
310208C	SM RAIL 208" CLR	208"
320240M	SM RAIL 240" MILL	240"
310240C	SM RAIL 240" CLR	240"
310240D	SM RAIL 240" DRK	240"

UNIRAC

1411 BROADWAY BLVD. NE
ALBUQUERQUE, NM 87102 USA
PHONE: 505.242.6411
WWW.UNIRAC.COM

PRODUCT LINE: SOLARMOUNT

DRAWING TYPE: PART DETAIL

DESCRIPTION: STANDARD RAIL

REVISION DATE: 9/11/2017

DRAWING NOT TO SCALE
ALL DIMENSIONS ARE
NOMINAL

PRODUCT PROTECTED BY
ONE OR MORE US PATENTS
LEGAL NOTICE

SM-P01

SHEET

UN

PRO SERIES END CLAMP

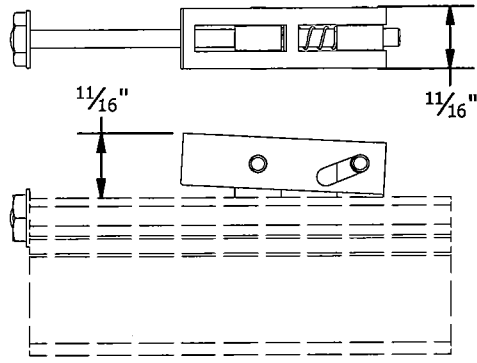

PRO SERIES MID CLAMP

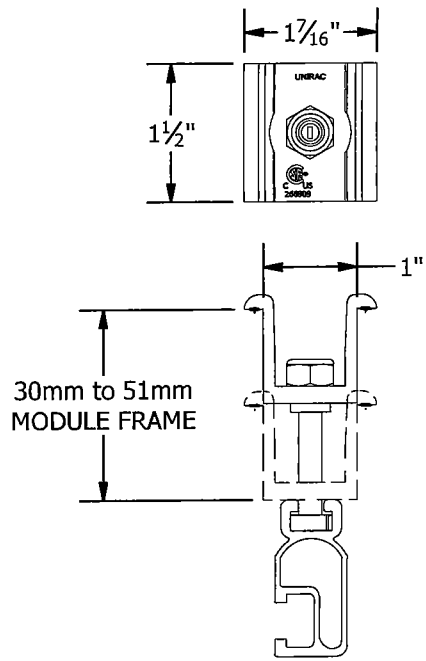

PART # TABLE	
P/N	DESCRIPTION
302035M	ENDCLAMP PRO
302030M	MIDCLAMP PRO - MILL
302030D	MIDCLAMP PRO - DRK

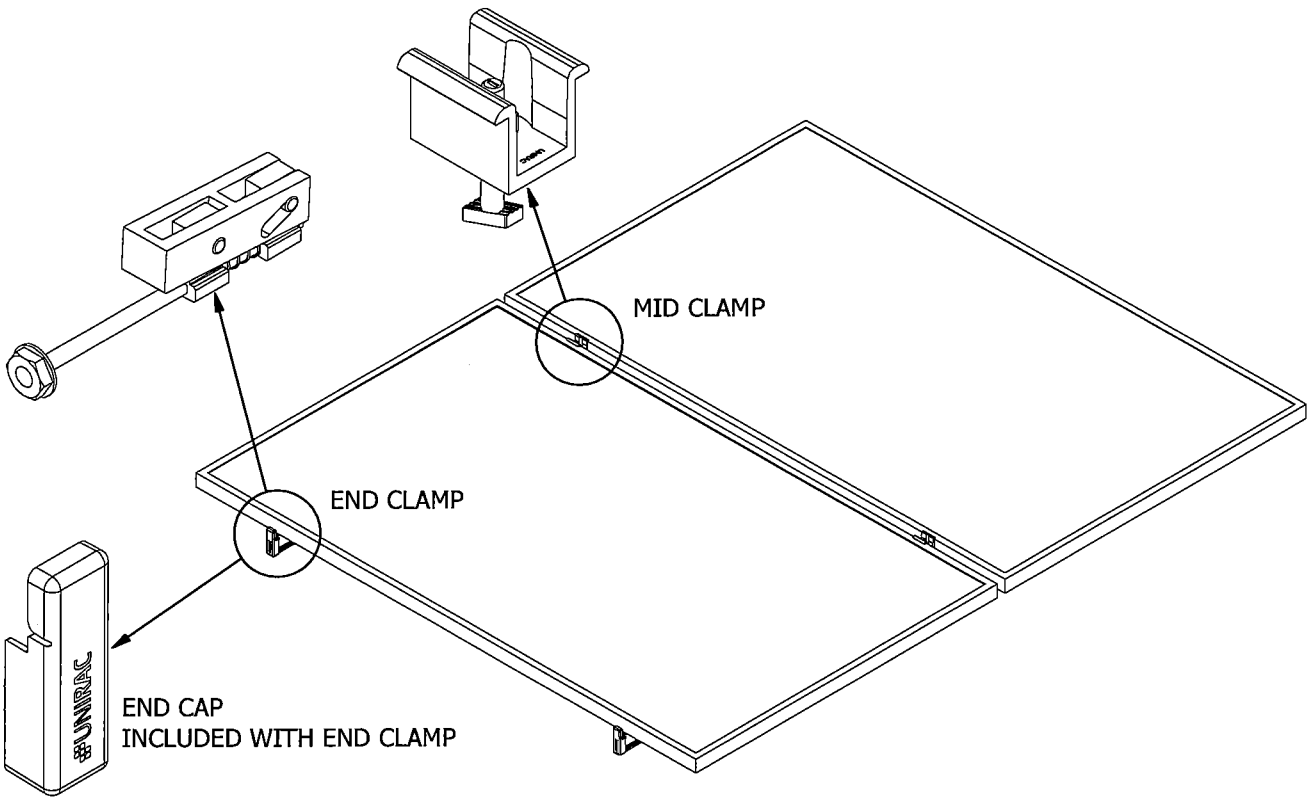

UNIRAC

1411 BROADWAY BLVD. NE
ALBUQUERQUE, NM 87102 USA
PHONE: 505.242.6411
WWW.UNIRAC.COM

PRODUCT LINE:	SOLARMOUNT
DRAWING TYPE:	PART & ASSEMBLY
DESCRIPTION:	PRO SERIES BONDING CLAMPS
REVISION DATE:	10/26/2017

DRAWING NOT TO SCALE
ALL DIMENSIONS ARE
NOMINAL

PRODUCT PROTECTED BY
ONE OR MORE US PATENTS
LEGAL NOTICE

SM-A01

SHEET

BONDING SPLICE BAR

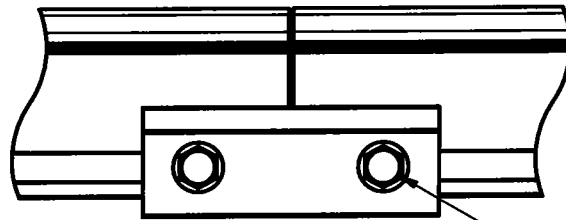
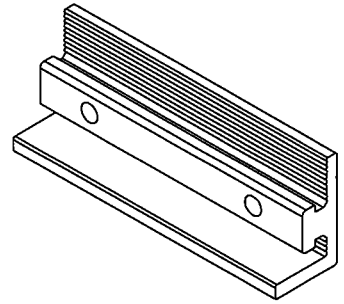
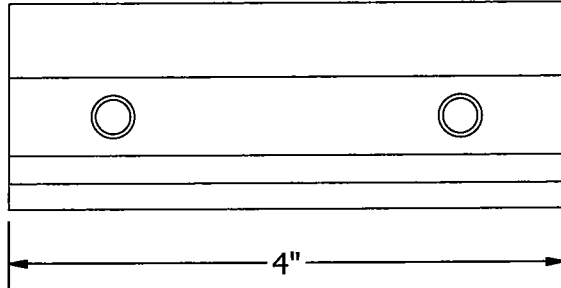
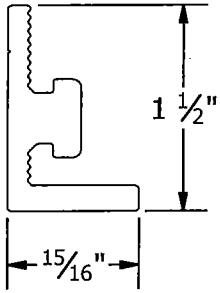

5/16"-18 TYPE F THREAD CUTTING SCREWS INCLUDED

TYPICAL SPLICE BAR DETAIL

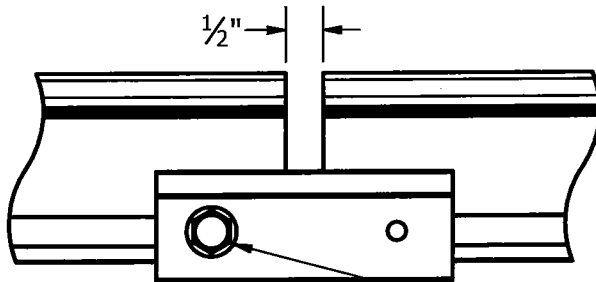

NOTE THAT ONLY 1 SCREW IS USED AT AN EXPANSION JOINT. THE SPLICE BAR DOES NOT BOND ACROSS AN EXPANSION JOINT. SEE INSTALLATION GUIDE FOR INSTRUCTION.

TYPICAL EXPANSION JOINT DETAIL

PART # TABLE	
P/N	DESCRIPTION
303019M	BND SPLICE BAR PRO SERIES MILL
303019D	BND SPLICE BAR PRO SERIES DRK

UNIRAC

1411 BROADWAY BLVD. NE
ALBUQUERQUE, NM 87102 USA
PHONE: 505.242.6411
WWW.UNIRAC.COM

PRODUCT LINE:	SOLARMOUNT
DRAWING TYPE:	PART & ASSEMBLY
DESCRIPTION:	BONDING SPLICE BAR PRO SERIES
REVISION DATE:	9/17/2019

DRAWING NOT TO SCALE
ALL DIMENSIONS ARE
NOMINAL

PRODUCT PROTECTED BY
ONE OR MORE US PATENTS
LEGAL NOTICE

SM-A05

SHEET

NOTES:

1. END CAP INCLUDED WITH EVERY END CLAMP.
2. END CAP FITS SOLARMOUNT LIGHT AND STANDARD RAIL PROFILES.

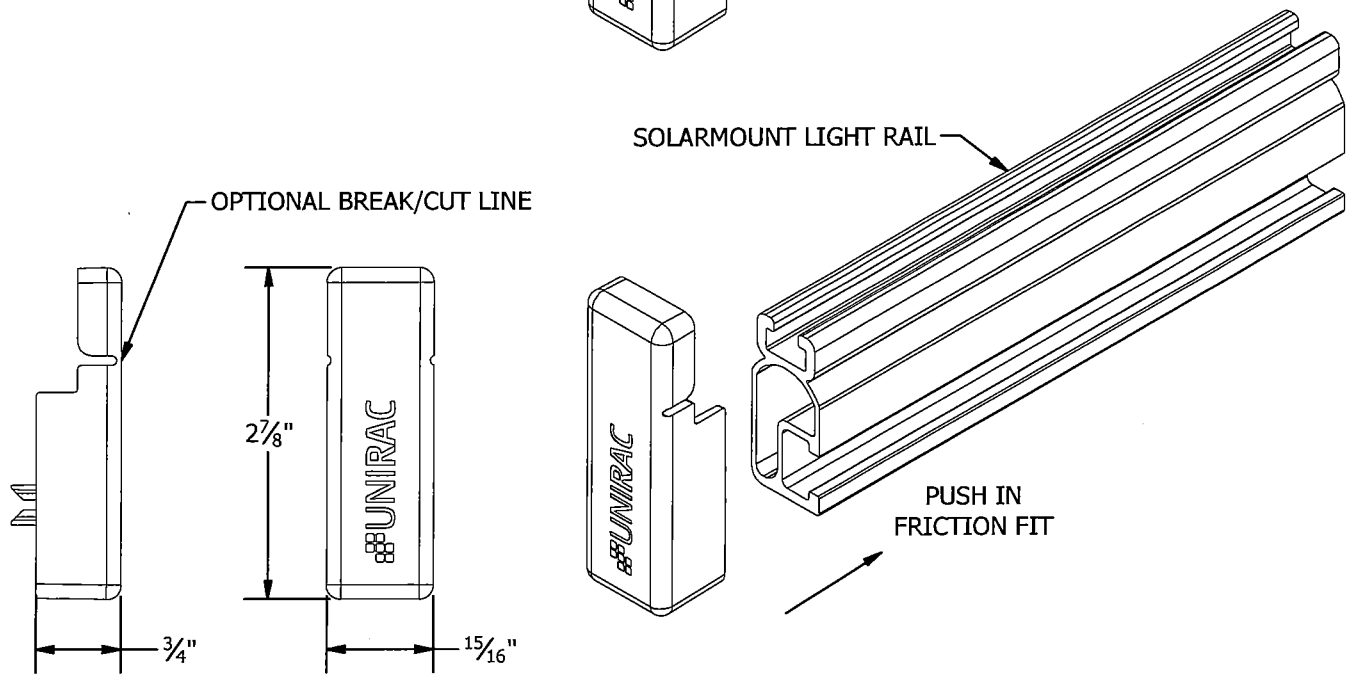
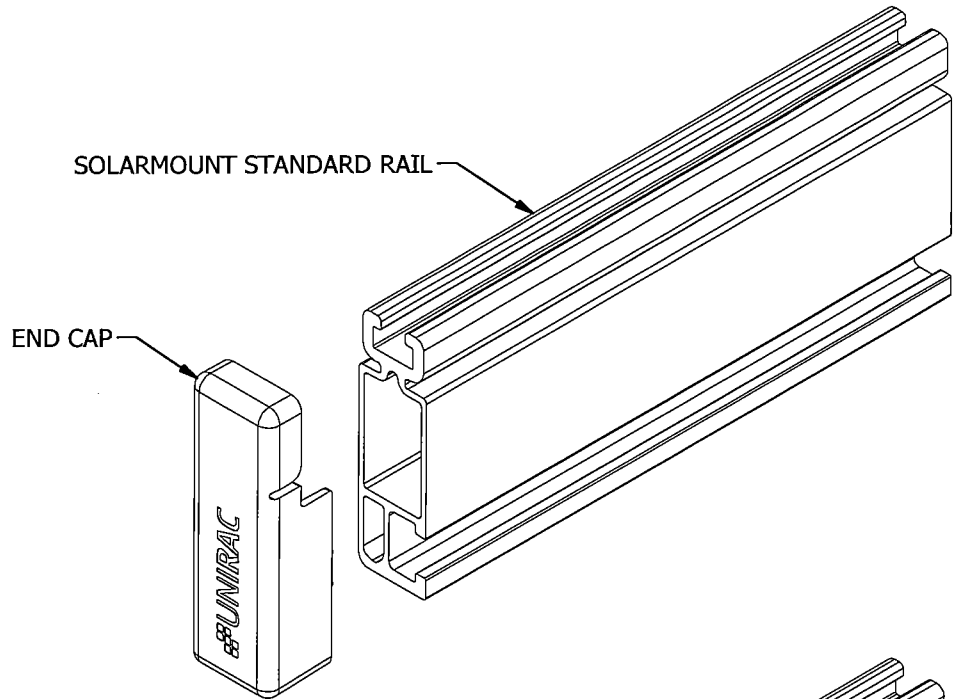

702

UM

UNIRAC

1411 BROADWAY BLVD. NE
ALBUQUERQUE, NM 87102 USA
PHONE: 505.242.6411
WWW.UNIRAC.COM

PRODUCT LINE:	SOLARMOUNT
DRAWING TYPE:	PART DETAIL
DESCRIPTION:	END CAPS
REVISION DATE:	9/27/2017

DRAWING NOT TO SCALE
ALL DIMENSIONS ARE
NOMINAL

PRODUCT PROTECTED BY
ONE OR MORE US PATENTS
LEGAL NOTICE

SM-P04
SHEET

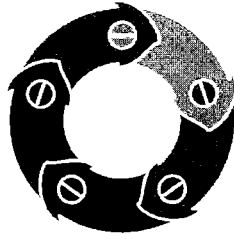

synerlution
energy

Water Storage System Documentation

7W

W

2221 Militar Ave Suite 103 Isabela, PR 00662 . (787) 493-0864 . (787) 493-0865

RO
T
V
C
V



AQUATROL™
PRESSURIZED TANKS



www.aquatroltech.com



5 YEAR WARRANTY

INLINE, VERTICAL & HORIZONTAL MODELS AVAILABLE

HEAVY DUTY DIAPHRAGM

DURABLE COLD ROLLED STEEL CONSTRUCTION

TRIPLE GRADE COATING FOR DURABILITY

Aquatrol Hydropneumatic Pressurized Tanks are an ideal product for well applications and for applications where you want to minimize pump start-ups every time you use water. When the pump fills the tank with water, the air above the diaphragm is compressed and the increased pressure inside the tank causes the pump to shut-off. Minimized pump starts and stops prevent motor damage due to excessive cycling of the pump, creates more consistent water pressure and provides savings through reduced energy use.

Aquatrol Hydropneumatic Pressurized Tanks are constructed using high strength cold rolled carbon steel for added strength and painted with triple grade enamel making them extremely durable in outdoor applications.

Aquatrol Hydropneumatic Pressurized Tanks come with stainless steel 304 NPT connections, offer a heavy-duty butyl rubber diaphragm and provide you with the peace of mind of an FDA grade polypropylene liner. This coupled with its 5-year warranty and durable design makes them the logical choice for industry professionals because of their cost to benefit ratio.

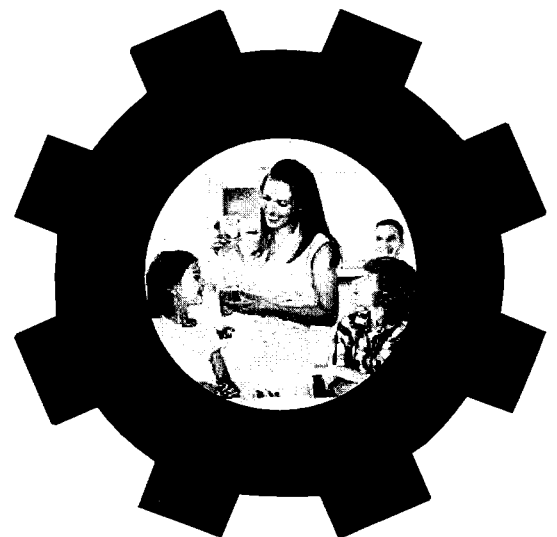

SPECIFICATIONS

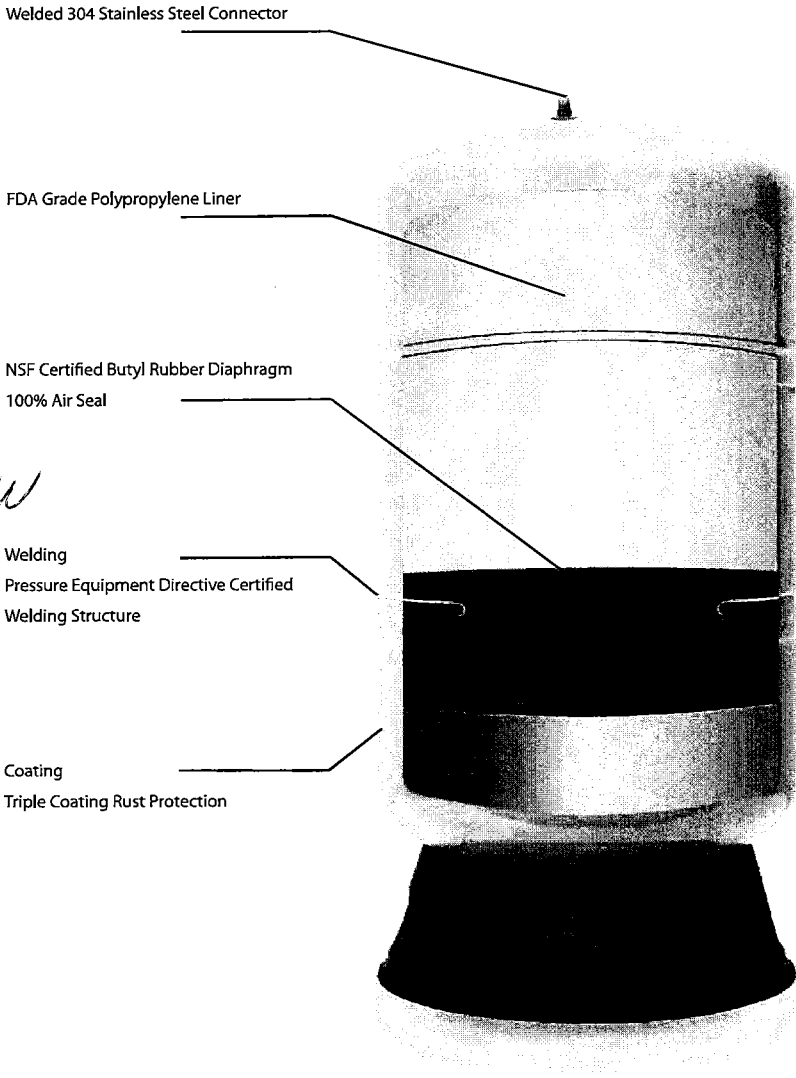

NITROGEN CHARGE ADVANTAGES

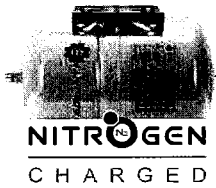

- ✓ LITTLE TO ZERO AIR REFILL
- ✓ NO PRESSURE CHANGES DUE TO TEMPERATURE CHANGES
- ✓ NITROGEN MIGRATION THROUGH DIAPHRAGM LESS LIKELY THAN OXYGEN
- ✓ FEWER PUMP START-UPS = ENERGY SAVINGS + EXTENDED PUMP LIFE

TANK SPECIFICATIONS

- FACTORY PRE-CHARGE: 30 PSI (2 BAR)
- MAX. WORKING TEMP: 200 °F (93 °C)
- MAX. WORKING PRESSURE: 150 PSI (10 BAR)

MATERIALS OF CONSTRUCTION

- SHELL: Cold Rolled Carbon Steel
- COATING: Triple Grade Enamel
- LINER: FDA GRADE Polypropylene
- DIAPHRAGM: Heavy-Duty Butyl Rubber
- CONNECTIONS: 304 Stainless Steel

WARRANTY

MANUFACTURER WARRANTY: 5 year Limited Warranty

WARNINGS



WARNING: BEFORE INSTALLATION, READ CAREFULLY THE PRODUCT INSTALLATION AND OPERATION INSTRUCTIONS MANUAL. FAILURE TO FOLLOW THE INSTRUCTIONS MAY RESULT IN SERIOUS OR FATAL INJURY AND/OR PROPERTY DAMAGE. FAILURE TO FOLLOW THE INSTRUCTIONS WILL VOID THE PRODUCT WARRANTY.



WARNING: EXPLOSION HAZARD! FAILURE TO FOLLOW THE INSTRUCTIONS IN THE PRODUCT MANUAL CAN CAUSE A RUPTURE OR EXPLOSION, POSSIBLY CAUSING FATAL OR SERIOUS INJURY, LEAKING, FLOODING AND/OR PROPERTY DAMAGE.



WARNING: THIS STORAGE TANK IS DESIGNED FOR OPERATION IN COLD WELL SYSTEMS AND LIMITED TO A WORKING PRESSURE OF NO GREATER THEN 125PSI. INSPECT TANK REGULARLY. IF SIGNS OF CORROSION ARE PRESENT, REMOVE TANK FROM OPERATION IMMEDIATELY.

Aquatrol will not be held responsible for damage deriving from improper use of the Hydro pneumatic Pressurized Tanks.

The amount of water delivered between pump cycles is called drawdown. The larger the well tank, the greater the drawdown capacity, the less the pump needs to run. This saves energy and money, and extends pump life. Larger tank sizes also increase the water storage volume to provide more consistent water pressure.

CONTINUOUS PRESSURE

LESS PUMP RUN-TIME

LESS PUMP START-UPS

EXTENDS PUMP LIFE

SAVES ENERGY

INCREASES WATER STORAGE

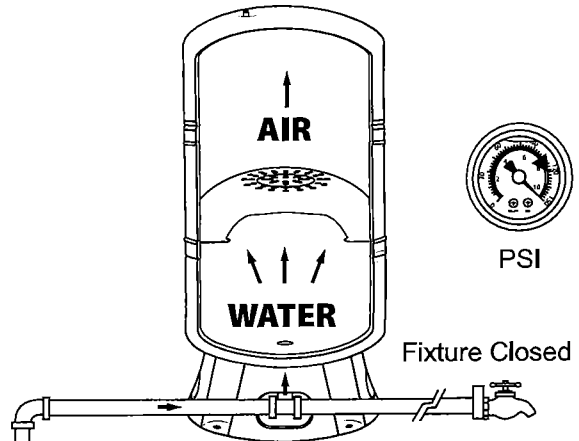

1. As the pump fills the tank with water, the air above the diaphragm is compressed. This increases the pressure in the tank and causes the pressure switch to turn off the pump.

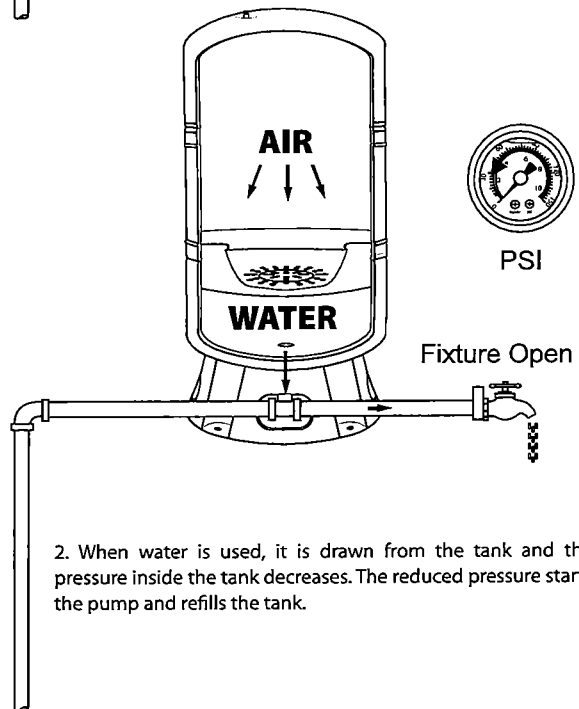

2. When water is used, it is drawn from the tank and the pressure inside the tank decreases. The reduced pressure starts the pump and refills the tank.

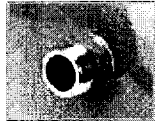

766

INLINE MODELS

Model Number	Tank Volume		Maximum Acceptance		Tank Diameter		Tank Height		Tank Connection (NPT)	Tank Weight	
	(gal)	(L)	(gal)	(L)	(in)	(cm)	(in)	(cm)		(lbs)	(kg)
ARO-305I-B10	0.5	3	0.25	0.95	5.1"	13	8.5"	21.5	1"	2.6	1.2
ARO-82I-B10	2	8	0.9	3.4	8"	20.3	11.4"	29	1"	5.5	2.3
ARO-1232I-B10	3.2	12	1.6	6.05	9.1"	23	15.4"	39	1"	7.5	3.2
ARO-1845I-B10	4.5	18	2.5	9.5	11"	28	15.4"	39	1"	8.5	3.7
ARO-246I-B10	6	24	3	11.4	11.6"	29.5	16.3"	41.5	1"	10.6	4.8
ARO-3810I-B10	10	38	5.2	19.7	11.6"	29.5	21.7"	55	1"	15	6.8

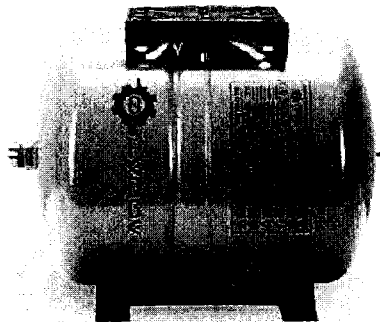

44

HORIZONTAL MODELS

Model Number	Tank Volume		Maximum Acceptance		Tank Diameter		Tank Height		Tank Length		Tank Connection (NPT)	Tank Weight	
	(gal)	(L)	(gal)	(L)	(in)	(cm)	(in)	(cm)	(in)	(cm)		(lbs)	(kg)
ARO-1845H-B10	4.5	18	2.5	9.5	11"	28	12"	30	15.4"	39	1"	10	4.4
ARO-246H-B10	6	24	3	11.4	11.6"	29.5	12.6"	32	16.3"	41.5	1"	12	5.4
ARO-3810H-B10	10	38	5.2	19.7	11.6"	29.5	12.6"	32	21.7"	55	1"	16.5	7.4
ARO-5814H-B10	14	58	11.3	42.8	15"	38.1	17"	42.5	22"	53	1"	24.5	11.1
ARO-8020H-B10	20	80	13	49.2	15"	38.1	17"	42.5	30"	73	1"	32.5	14.7

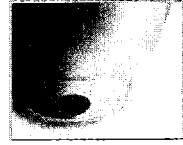
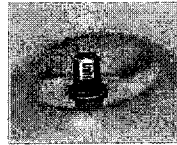
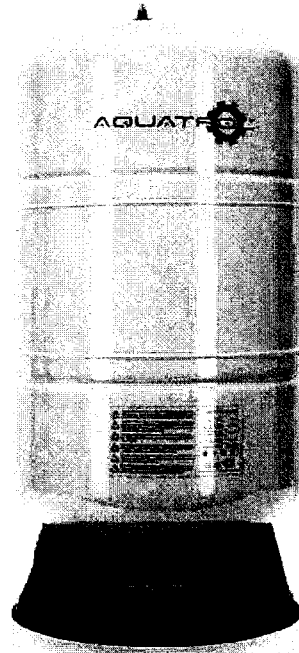

VERTICAL MODELS

Model Number	Tank Volume		Maximum Acceptance		Tank Diameter		Tank Height		Tank Connection (NPT)	Tank Weight	
	(gal)	(L)	(gal)	(L)	(in)	(cm)	(in)	(cm)		(lbs)	(kg)
ARO-5814V-B10	14	58	11.3	42.8	15"	38.1	23.6"	66	1"	24.5	11
ARO-8020V-B10	20	80	13	49.2	15"	38.1	30.7"	78	1"	32.5	14.6
ARO-10025V-B10	28	100	15	56.8	15"	38.1	39.2"	99.5	1"	40.5	18.4
ARO-12032V-B10	32	120	16	60	15"	38.1	44"	112	1"	50	22.7
ARO-13034V-B114	34	130	22.5	85	22"	55.9	29.5"	75	1 1/4"	54	24.5
ARO-16044V-B114	44	160	30	113.6	22"	55.9	36"	91.5	1 1/4"	61.5	27.8
ARO-23562V-B114	62	235	35.2	133	22"	55.9	45.7"	116	1 1/4"	83	37.7
ARO-30582V-B114	82	305	44	166.5	22"	55.9	57.1"	145	1 1/4"	104	47.1
ARO-450120V-B114	120	450	46.8	177.1	25.6"	65	55.2"	140	1 1/4"	135.6	61.5

NOTE: TANKS 34 GAL AND ABOVE HAVE A METAL TANK BASE.

TERMS AND CONDITIONS

The products described in this document are hereby offered for sale to be established by Hydrofit Quick Connect Fittings, Polaris Scientific Ultraviolet, Hydron Membranes, Aquatrol, Shok Blok, HydroGuard, Hydronix Water Technology, any of its subsidiaries and its authorized distributors. This offer and its acceptance by any customer (the "Buyer") shall be governed by all of the following Terms and Conditions. Buyer's order for any item described in this document, when communicated to Hydrofit Quick Connect Fittings, Polaris Scientific Ultraviolet, Hydron Membranes, Aquatrol, Shok Blok, HydroGuard, Hydronix Water Technology, its subsidiaries or an authorized distributor (the "Seller") verbally or in writing, shall constitute acceptance of this offer. Provided, however, that these terms and conditions shall not operate as a rejection of the Buyer's offer unless such offer contains variances in the description, quantity, price, or delivery schedule of the items.

1. Terms and Conditions of Sale.

All descriptions, quotations, proposals, offers, acknowledgments, acceptances and sales of the Seller's products are subject to and shall be governed exclusively by the terms and conditions stated herein (the "Agreement"). The Buyer's acceptance of any offer to sell is limited to the terms and conditions in the Agreement. Any terms or conditions in addition to or inconsistent with those stated in the Agreement, proposed by the Buyer in any acceptance of an offer by the Seller, are hereby rejected. No such additional, different or inconsistent terms and conditions shall become part of the agreement between the Buyer and the Seller unless expressly accepted in writing by the Seller. The Seller's acceptance of any offer to purchase by the Buyer is expressly conditioned upon the Buyer's assent to all the terms and conditions in this Agreement, irrespective of any terms in addition to, or inconsistent with those contained in the Buyer's offer. Acceptance of the Seller's products shall in all events constitute such assent.

2. Documents.

Unless provided otherwise in the Agreement, all catalog descriptions, illustrations, drawings and literature or independently submitted estimates of performance, weights and measurements or other specifications provided by the Seller are mere approximations and the Seller reserves the right to alter or amend them at any time. The Seller reserves the right to correct clerical or technical errors in the contract documents. The Buyer shall furnish with his order all necessary specifications and information. The Seller takes no responsibility for goods manufactured, priced or delivered not in accordance with the order or the specifications unless the Buyer's order and specifications are clear and correct.

3. Prices.

Unless otherwise provided, all prices contained in our quotations and written acceptances are ex-works and do not include the cost of packing. All orders are accepted on the condition that all such prices are subject to revision by the Seller at any time before the goods are dispatched to take account of any price change. In the event that the Buyer does not place the entire order quoted by the Seller for the Buyer, the Seller reserves the right to revise its prices. The Seller also reserves the right to revise its prices if the Buyer modifies the specification or quantity of the goods or the delivery requirements after the order has been accepted by the Seller.

4. Advice.

All advice given in connection with the Seller's goods is provided without charge to the Buyer. ANY ADVICE AND ASSISTANCE GIVEN BY THE SELLER TO THE BUYER IS GIVEN AT THE BUYER'S RISK, AND THE SELLER SHALL NOT BE LIABLE FOR ANY LOSS, DAMAGE OR CLAIM ARISING THEREFROM.

5. Payment.

(a) Unless otherwise provided in the Agreement, or explicitly agreed upon in writing by the Seller, payment is due in full 30 days from date of shipment of the items purchased herein under. (b) In the case of an installment contract, deliveries or parts, payment for each installment delivery or part shall be made under sub-clause (a) as if the same constituted a separate agreement. (c) Amounts not timely paid shall bear interest at the rate of 2-1/2% above the Seller's bank's prime rate from time to time in force. (d) In the event that the Buyer fails within one calendar month of the date for payment to effect any payment which may be due under the Agreement or any agreement with the Seller, or if the Buyer commits any breach of the Agreement, or if the Buyer becomes insolvent or commits any act of bankruptcy or contemplation of liquidation, the Seller will be entitled, without prejudice to the Seller's other rights, to terminate the Agreement or any unfulfilled part thereof, or at the Seller's option to make partial deliveries.

6. Modifications and Cancellations.

This Agreement is not subject to oral modification or cancellation. A Buyer's request for modification or cancellation will not be incorporated into the Agreement unless the request is accepted by the Seller in a writing that amends the Agreement. Acceptance of any such requested modification or cancellation shall be at the Seller's discretion and shall be upon such terms and conditions as the Seller may require.

7. Handling Charge.

Goods supplied in accordance with the Buyer's order may later be returned to the Seller at the Seller's discretion provided the return is pre-authorized in writing, and the merchandise is unused, in original packages, unaltered, clean and no older than 60 days from the date of shipment by the Seller. The Buyer will be required to pay to the Seller a handling charge of 25% of the purchase price of the returned goods. A copy of the original invoice for the merchandise must accompany all returns.

8. Delivery.

(a) Any delivery dates quoted are approximate only and the Seller shall have no liability for any delays in delivery. (b) Unless provided otherwise, delivery of the goods shall be made when the Seller has notified the Buyer that the goods are ready for dispatch. Regardless of the method of delivery, delivery shall be made F.O.B. Seller's plant, where the risk of loss shall thereupon pass to the Buyer upon the Seller's delivery to a carrier. Notwithstanding that the Seller's prices are ex-works, the Seller is prepared by special contract to procure carriage or freight and insurance on behalf of the Buyer and at Buyer's cost in which event the Seller shall be under no liability for damage in transit or loss or damage to the goods beyond the point at which the Seller contracts to deliver the same. (c) The Seller will not make drop shipments.

9. Inspection and Rejection.

(a) The following provisions shall apply in relation to all deliveries of goods: the Seller shall not be held liable for any claims of damage in transit, shortage of delivery or loss of goods, unless in the case of shortage of delivery, a separate notice in writing is given to the carrier concerned and to the Seller within three (3) days of the receipt of the goods, followed by a complete claim in writing within five (5) days of receipt of the goods and in the case of loss of goods, a separate notice in writing is given to the carrier concerned and to the Seller and a complete claim in writing made within thirty (30) days of the date of consignment. The Buyer must inspect the goods on arrival from the carrier; however, where goods are accepted from the carrier concerned without being inspected, the delivery book of the carrier concerned must be signed "not examined". The Seller shall have the right to inspect the goods at the Buyer's premises in respect to any such claims made by the Buyer and the Buyer shall retain such goods until the Seller has inspected such goods or until the Seller has notified the Buyer that the Seller does not wish to inspect such goods. Any breach of these conditions in this provision shall serve as a waiver to any claim brought by the Buyer. (b) Without prejudice to the Seller's other rights, should the Buyer fail for any reason to send the Seller forwarding instructions within ninety (90) days after the date of the Seller's notification that the goods are ready for dispatch or to accept delivery of the goods, the Seller shall be entitled at the Buyer's risk and expense to store the goods and/or to procure or effect storage of the goods elsewhere. Goods so stored shall be paid for as if they had been dispatched and/or accepted.

10. Test and Performance.

(a) The Seller's goods are, where practicable, submitted to the Seller's standard test before delivery. If special tests are required, these shall be made at the Seller's premises unless otherwise agreed, and will be subject to an extra charge. (b) The Seller accepts no liability for failure to attain any performance figures quoted by the Seller unless the Seller specifically has guaranteed them with an agreed sum as liquidation damages and the Buyer has suffered actual loss by reason of the failure to attain the figures quoted. (c) Any particulars of weights and measurements, power and consumption, power output or performance relating to the goods and like matters furnished by the Seller to the Buyer in the Seller's catalogs, literature or otherwise, are approximate and are intended only to present a general idea of the goods to be supplied and unless previously agreed specifically in writing shall not form part of the Agreement.

11. Buyer's Property.

Any designs, tools, patterns, materials, drawings, confidential information or equipment furnished to the Seller by the Buyer, or any other items which become the Buyer's property, may be considered obsolete and may be destroyed by the Seller after two (2) consecutive years have elapsed without the Buyer placing an order for the items which are manufactured using such property. The Seller shall not be responsible for any loss or damage to such property while it is in the Seller's possession or control.

12. Taxes.

Unless otherwise indicated, all prices and charges are exclusive of excise, sales, use, property, occupational or like taxes which may be imposed by any taxing authority upon the manufacture, sale or delivery of the items sold hereunder. If any such taxes must be paid by the Seller, or if the Seller is liable for the collection of such tax, the amount thereof shall be in addition to the amounts for the item sold. The Buyer agrees to pay all such taxes or to reimburse the Seller thereupon receipt of its invoice. If the Buyer claims exemption from any sales, use or other tax imposed by any taxing authority, the Buyer shall promptly indemnify and hold the Seller harmless from and against any such tax, as well as any interest or penalties thereon which may be assessed if the items are held to be taxable.

13. Warranty.

EXCEPT AS EXPRESSLY WARRANTED IN WRITING BY THE SELLER, THE GOODS SOLD BY THE SELLER ARE PURCHASED BY THE BUYER "AS IS". THE SELLER DOES NOT WARRANT THAT THE GOODS ARE OF MERCHANTABILITY OR THAT THEY CAN BE USED FOR ANY PARTICULAR PURPOSE. EXCEPT AS EXPRESSLY WARRANTED IN WRITING BY THE SELLER, THE SELLER MAKES NO REPRESENTATION OR WARRANTY OF ANY KIND WITH RESPECT TO THE PRODUCTS.

(a) The Seller warrants that the items sold hereunder shall be free from defects in material or workmanship at the time of shipment by the Seller. The Seller warrants that if within 12 months of delivery of the goods to the Buyer the Buyer returns immediately to the Seller's premises any of the said goods which the Buyer believes to be defective, carrier paid, properly packed and clearly marked with the Buyer's full name and address and any other information such as serial numbers which may be necessary to enable the goods to be identified, together with a complete description of the alleged defect, they will be repaired or new goods will be supplied in exchange and the goods so repaired or such new goods will be delivered to the Buyer free of charge at the Seller's premises; provided, however, that the foregoing warranty shall be applicable only if upon demand by the Seller, the Buyer proves to the Seller's satisfaction: (i) that the defect was due solely to defective workmanship; (ii) that no alterations or repairs have been made to the goods except with the Seller's written consent; (iii) that the defect was not caused by any act of the Buyer or its agents; and (iv) that the defect was not caused by any matter beyond the reasonable control of the Seller, including, without limitation, accident or normal wear and tear. (b) THIS WARRANTY DOES NOT APPLY UNLESS THE SELLER'S PRODUCTS ARE: (I) USED IN DOMESTIC PLUMBING APPLICATIONS; (II) INSTALLED BY A LICENSED CONTRACTOR, PLUMBER OR QUALIFIED EQUIPMENT INSTALLATION PROFESSIONAL; AND (III) INSTALLED AND OPERATED IN ACCORDANCE WITH PUBLISHED HYDROFIT / HYDRONIX WATER TECHNOLOGY SPECIFICATIONS. (c) All costs and expenses, including freight charges, customs duties, and insurance incurred in returning the goods to the Seller's premises in accordance with this provision shall be paid by the Buyer. The benefit of this warranty shall not be assignable by the Buyer. (d) THIS WARRANTY DOES NOT EXTEND TO ANY GOODS NOT MANUFACTURED BY THE SELLER EVEN THOUGH SUPPLIED BY THE SELLER NOR DOES IT EXTEND TO ANY SECOND-HAND OR RECONDITIONED GOODS NOR DOES IT EXTEND TO COMPONENTS MANUFACTURED BY THE SELLER BUT INSTALLED, ATTACHED OR WELDED BY THE BUYER OR HIS CUSTOMER ON EQUIPMENT NOT MANUFACTURED BY THE SELLER. GOODS NOT MANUFACTURED BY THE SELLER CARRY ONLY THE WARRANTY (IF ANY) OF THEIR MAKERS AND THE BUYER IS ENTITLED TO THE BENEFIT THEREOF ONLY SO FAR AS THE SELLER HAS THE POWER TO TRANSFER IT. (e) THIS WARRANTY COMPRISES THE SOLE AND ENTIRE WARRANTY PERTAINING TO ITEMS PROVIDED HEREUNDER; THE SELLER MAKES NO OTHER WARRANTY, GUARANTEE, OR REPRESENTATION OF ANY KIND WHATSOEVER. ALL OTHER WARRANTIES, INCLUDING BUT NOT LIMITED TO MERCHANTABILITY AND FITNESS FOR PURPOSE, WHETHER EXPRESSED OR IMPLIED, OR ARISING BY OPERATION OF LAW, TRADE USAGE, OR COURSE OF DEALING, ARE HEREBY DISCLAIMED. (f) NOTWITHSTANDING THE FOREGOING, THERE ARE NO WARRANTIES WHATSOEVER ON ITEMS BUILT OR ACQUIRED WHOLLY OR PARTIALLY TO THE BUYER'S DESIGNS OR SPECIFICATIONS.

14. Limited Remedy.

THE SELLER'S LIABILITY ARISING FROM OR IN ANY WAY CONNECTED WITH THE ITEMS SOLD OR THIS AGREEMENT SHALL BE LIMITED EXCLUSIVELY TO REPAIR OR REPLACEMENT OF THE ITEMS SOLD. IN NO EVENT SHALL THE SELLER BE LIABLE TO THE BUYER OR ANY THIRD PARTY FOR ANY INCIDENTAL, CONSEQUENTIAL OR SPECIAL DAMAGES OF ANY KIND OR NATURE WHATSOEVER, INCLUDING BUT NOT LIMITED TO LOST PROFITS ARISING FROM OR IN ANY WAY CONNECTED WITH THIS AGREEMENT OR ANY ITEMS SOLD, WHETHER ALLEGED TO ARISE FROM BREACH OF CONTRACT, EXPRESS OR IMPLIED WARRANTY, OR IN TORT, INCLUDING WITHOUT LIMITATION, NEGLIGENCE, FAILURE TO WARN OR STRICT LIABILITY. IN NO EVENT SHALL THE SELLER BE LIABLE TO THE BUYER OR ANY OTHER ENTITY FOR MORE THAN THE INVOICE PRICE RECEIVED BY THE SELLER FOR ANY NON-CONFORMING PRODUCTS. THE SELLER SHALL NOT BE LIABLE TO THE BUYER OR ANY OTHER ENTITY FOR PERSONAL INJURY, PROPERTY DAMAGE, OR ANY DIRECT, INDIRECT, SPECIAL, INCIDENTAL, CONSEQUENTIAL, PUNITIVE, EXEMPLARY, SPECIAL, OR OTHER DAMAGES OF ANY KIND, INCLUDING WITHOUT LIMITATION THE COST OF PROCUREMENT OF SUBSTITUTE GOODS, THE LOSS OF PROFITS, PRODUCTS, OR PRODUCTION, OR THE INTERRUPTION OF BUSINESS, HOWEVER CAUSED. THE SELLER SHALL NOT BE LIABLE TO THE BUYER OR ANY OTHER ENTITY ON ANY THEORY OF LIABILITY INCLUDING WITHOUT LIMITATION BREACH OF CONTRACT OR EXPRESS OR IMPLIED WARRANTY, TORT, NEGLIGENCE, FAILURE TO WARN, OR STRICT LIABILITY, AND WHETHER OR NOT THE SELLER HAS BEEN ADVISED OF THE POSSIBILITY OF SUCH DAMAGES. THE ESSENTIAL PURPOSE OF THIS PROVISION IS TO LIMIT THE LIABILITY OF THE BUYER ARISING OUT OF THE SALE OF PRODUCTS TO THE BUYER WHETHER FOR BREACH OF CONTRACT, NEGLIGENCE, OR ANY OTHER THEORY OF LIABILITY. THESE LIMITATIONS SHALL APPLY NOTWITHSTANDING ANY FAILURE OF ESSENTIAL PURPOSE OR ANY LIMITED REMEDY AND NOTWITHSTANDING THE PROVISIONS OF ANY OTHER AGREEMENT BETWEEN THE SELLER AND THE BUYER.

15. Indemnity for Infringement of Intellectual Property Rights.

(a) The Buyer shall defend and indemnify the Seller against all actions, claims, demands, penalties and costs by third parties in tort, or for infringement, or alleged infringement, of patents, trademarks, copyrights, trade dress, trade secret or other rights of any third party resulting from the goods manufactured in accordance with the Buyer's specifications or based on any information provided by the Buyer. The Buyer will defend any action against the Seller for title, patent, trademark, copyright infringement, or other claimed by a third party at the Buyer's sole cost and expense. (b) The Seller shall have no liability for infringement of any patents, trademarks, copyrights, trade dress, trade secrets or similar rights except as provided in this provision. The Seller will defend and indemnify the Buyer against allegations of infringement of patents, trademarks, copyrights, trade dress and trade secrets ("Intellectual Property Rights"). The Seller will defend at its expense and will pay the cost of any settlement or damages awarded in an action brought against the Buyer based on an allegation that an item sold pursuant to this contract infringes the Intellectual Property Rights of a third party. The Seller's obligation to defend and indemnify the Buyer is contingent on the Buyer notifying the Seller within 10 days after sole control over the defense of any allegations or actions, including all negotiations for settlement or compromise. If an item sold hereunder is subject to a claim that it infringes the Intellectual Property Rights of a third party, the Seller may, at its sole expense and option, procure for the Buyer the right to continue using said item, replace or modify said item so as to make it non-infringing, or offer to accept return of said item and return the purchase price less a reasonable allowance for depreciation. Notwithstanding the foregoing, the Seller shall have no liability for claims of infringement based on information provided by Buyer, or directed to items delivered hereunder for which the designs are specified in combination or use in a system of any item sold hereunder. The foregoing in this provision shall constitute the Seller's sole and exclusive liability and the Buyer's sole and exclusive remedy for infringement of Intellectual Property Rights.

16. Lien.

In addition to any right of lien to which the Seller may by law be entitled, the Seller shall have a general lien on all goods of the Buyer in the Seller's possession (although such goods or some of them may have been paid for) for the unpaid price of any other goods sold and delivered to the Buyer by the Seller under the same or other contracts.

17. Waiver.

The Seller's rights shall not be affected or restricted by any indulgence or forbearance granted to the Buyer. No waiver by the Seller of any breach shall operate as a waiver of any later breach.

18. Force Majeure.

The Seller shall be excused from performing any of its obligations under this Agreement which are prevented or delayed by any occurrence not within the reasonable control of the Seller, including but not limited to, accidents, acts of God, destruction or damage to the goods or the Seller's manufacturing plant, delays or failures in delivery of carriers or suppliers, shortages of materials, strikes or other labor matters, floods, earthquakes, fire, riots, explosions, or any regulations, rules, ordinances or orders of any governmental authority, federal, state or local, whether such cause exists at the date of the order or not.

19. Buyer's Representation of Solvency.

The Buyer hereby represents that as of the signing of this Agreement it was not insolvent within the meaning of the Uniform Commercial Code or any Bankruptcy Laws.

20. Assignment and Delegation.

The rights and obligations of the parties under this Agreement may not be assigned or delegated, except on the express written consent of the other party to the assignment or delegation.

21. Integration.

The rights and obligations of the parties and the terms and conditions set forth herein, together with any amendments, modifications and any different terms and conditions expressly accepted by the Seller in writing, shall constitute a complete and exclusive statement of the terms of this Agreement. This Agreement supersedes not only all prior agreements, but also oral agreements made contemporaneously with the execution of this Agreement. All such materials may not be used to supplement, explain, or contradict the terms of this Agreement.

22. Severability.

If any of these conditions or any part thereof purports to exclude or restrict or limit any liability and such exclusion or restriction or limitation is prohibited or rendered void or unenforceable by any legislation to which it is subject, or is itself prohibited or rendered void or unenforceable by any legislation to which it is subject, then the exclusion, restriction or limitation on the condition or part thereof in question shall be so prohibited or rendered void or unenforceable and the validity or enforceability of any other part of these provisions shall not thereby be affected.

23. Governing Law/Limitation on Actions.

The terms, conditions, rights, and obligations under this Agreement shall be construed under the laws of the State of California, without regard to principles of conflicts of laws. No actions arising out of the sale of the items sold hereunder or this Agreement may be brought by the Buyer more than two (2) years after such cause of action accrues.

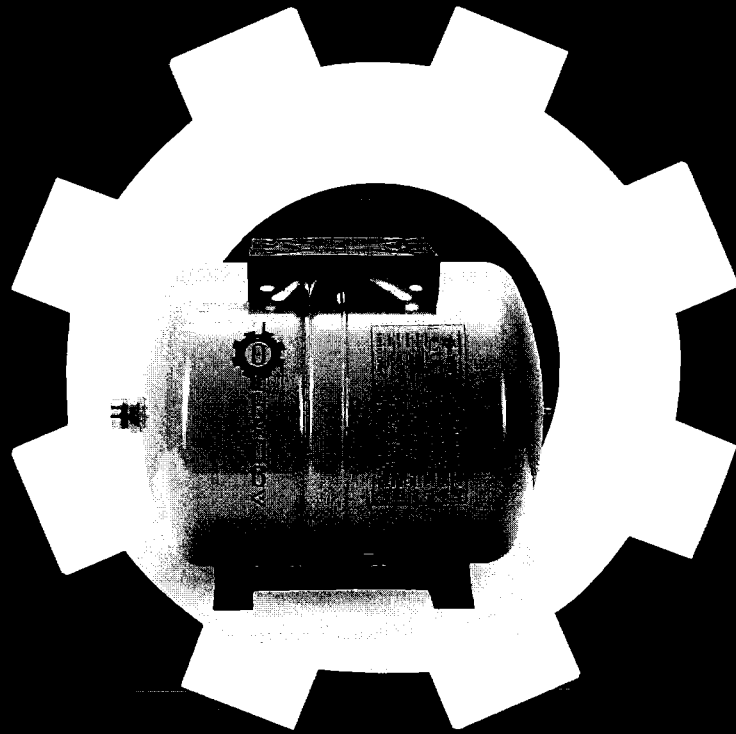

AQUATROL™
PRESSURIZED TANKS

P.O. Box 2235 Chino Hills, CA 91709 - USA

WAYNE®

MODEL: SWS50, 1/2 HP, MODEL: SWS75, 3/4 HP, MODEL: SWS100, 1 HP

WELL PUMP

WAYNE Shallow Well Jet Pump

CONSTRUCTION

- Corrosion Resistant All Cast Iron Motor Housing
- 3/4 in. NPT Discharge
- Reliable Thermoplastic Impeller for Maximum Water Flow
- Dual Voltage 120 V / 240 V and a 30/50 Pressure Switch included

BENEFITS

- This pump is assembled in the USA to deliver dependable performance that lasts for years.
- Fresh, clean, water is important to you and our pumps are designed to dependably deliver it to your home or business.
- Self priming and designed to reliably pump water from 25 ft. deep wells, or shallower.
- SWS50: Pump Part #56907
- SWS75: Pump Part #56914
- SWS100: Pump Part #56921

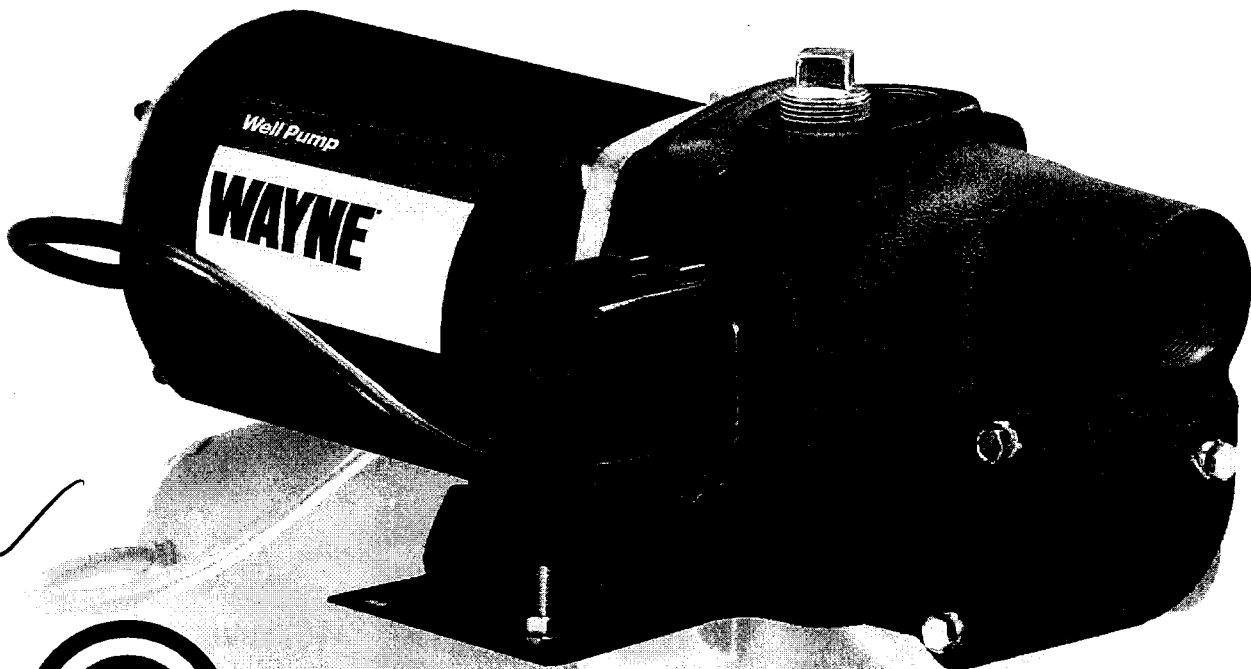

WELL PUMP

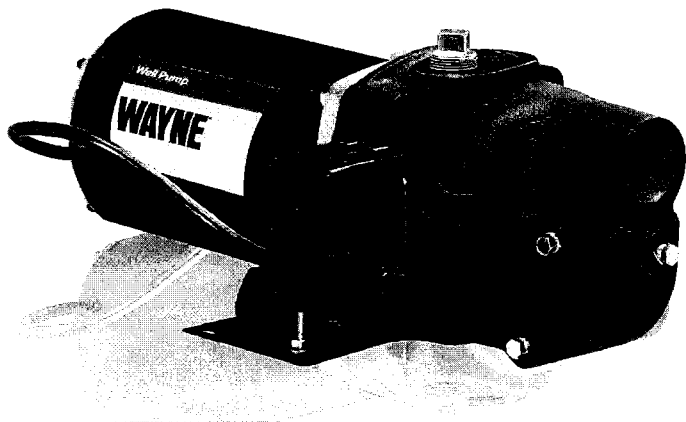

WAYNE SHALLOW WELL JET PUMP

MODEL: SWS50, 1/2 HP, MODEL: SWS75, 3/4 HP, MODEL: SWS100, 1 HP

PUMP SNAPSHOT

- **HP** - SWS50, 1/2 HP | SWS75, 3/4 HP | SWS100, 1 HP
- **Construction** - Cast Iron
- **Switch Type** - N/A
- **Motor** - 120/240V Split Phase Oil-Filled
- **Impeller** - Centrifugal
- **Intake** - 1 1/4 in. NPT
- **Discharge** - 3/4 in.
- **Submersible** - N/A
- **SWS50 UPC** - 040066106117
- **SWS75 UPC** - 040066106131
- **SWS100 UPC** - 040066106155

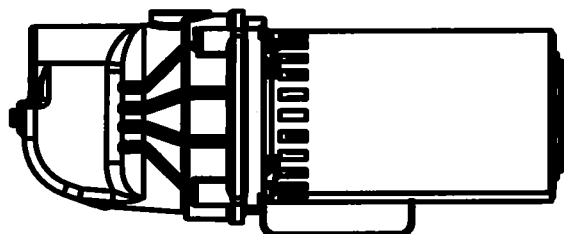
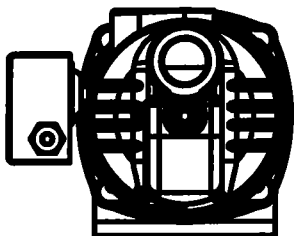

PUMP SPECIFICATIONS

- **Length** - 24 In.
- **Width** - 12 1/2 In.
- **Height** - 8 In.
- **Weight** - 43.6 Lbs.
- **Power Cord** - Wire in Field

PERFORMANCE

- **SWS50** - 1/2 HP - Max Flow 711 GPH: 674 GPH @ 5ft.
- **SWS75** - 3/4 HP - Max Flow 779 GPH: 750 GPH @ 5ft.
- **SWS100** - 1 HP - Max Flow 1084 GPH: 1022 GPH @ 5ft.

PERFORMANCE: SWS100, SWS75, SWS50

MODEL	PSI	MAX FLOW	5'	10'	15'	20'	25'
SWS100	30	1084	1022	960	899	837	775
	40	799	737	675	613	551	490
	50	513	451	389	328	266	204
SWS75	30	779	750	721	691	662	633
	40	644	615	586	557	528	499
	50	510	481	451	422	393	364
SWS50	30	711	674	638	601	565	529
	40	543	506	470	433	397	361
	50	375	338	302	265	229	193

FLOW RATE: GALLONS PER HOUR

SWS50 - 1/2 HP	GPH @ 5'	GPH @ 10'	GPH @ 15'	GPH @ 20'
Gal/Hr @0 Max Flow 711	674 @ 30 PSI	638 @ 30 PSI	601 @ 30 PSI	565 @ 30 PSI
SWS75 - 3/4 HP	GPH @ 5'	GPH @ 10'	GPH @ 15'	GPH @ 20'
Gal/Hr @0 Max Flow 779	750 @ 30psi	721 @ 30 PSI	691 @ 30 PSI	662 @ 30 PSI
SWS100 - 1 HP	GPH @ 5'	GPH @ 10'	GPH @ 15'	GPH @ 20'
Gal/Hr @0 Max Flow 1084	1022 @ 30 PSI	960 @ 30 PSI	899 @ 30 PSI	837 @ 30 PSI

3 YEAR LIMITED WARRANTY

- Assembled in USA with Foreign and Domestic Parts
- 30/50 Pressure Switch Included

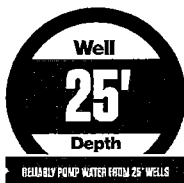

EXPORT PUMP TANK FEATURES

- Drawn Steel Construction
- Diaphragm Operation
- Corrosion Resistant Base
- Lightweight
- Maximum Working Pressure 100 psi
- Pre-Charged at 25 psi

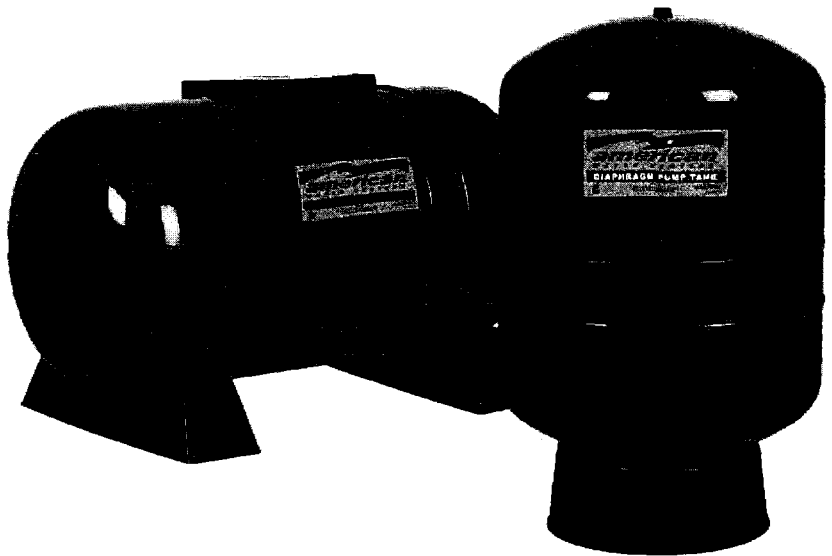

Certified to NSF/ANSI
61-G and 372

EXPORT PUMP TANK PRE-PRESSURIZED DIAPHRAGM OPERATION

American export pump tanks are designed for installation flexibility, and years of trouble-free service. Smooth, dependable diaphragm design and operation provides precise control of system operation cycles. Free-standing and in-line vertical tanks are available, as well as horizontal tanks with universal pump mounting bracket.

HIGHER DRAWDOWN THAN COMPETITION!

The industry's most popular "standard" tank sizes are 32-gallon and 44-gallon. American offers 36 gallon and 52-gallon tanks in the same price range. A 36-gallon American delivers 12% higher drawdown than the industry standard. A 52-gallon American delivers 18% higher drawdown than standard.

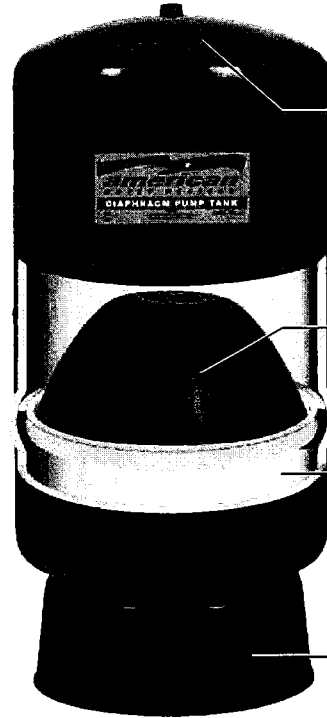

Projection welded air charge valve.

Butyl rubber parabolic diaphragm ensures separation of air and water. Steel retaining ring "seals" diaphragm directly to tank.

Powder coated water chamber, proven protection against internal corrosion.

Rotating corrosion resistant base assures stability. Rotates for easy alignment to connection. Slotted and notched for proper airflow, reduced condensation.



IN-LINE TANKS

In-Line Series tanks, available in 2, 4.6, and 7.3-gallon sizes and are designed to be supported by system piping (See Typical Installations, page 5).

PRE-PRESSURIZED PUMP TANK OPERATION CYCLES



START-UP CYCLE*

Diaphragm is pressed against the bottom of the chamber.

*Based on 30-50 operating system.

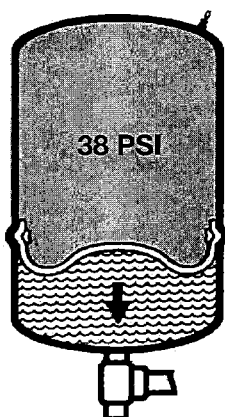

FILL CYCLE*

Water is pumped into the reservoir, which forces the diaphragm upward into the air chamber.

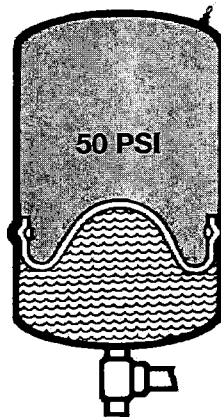

HOLD CYCLE*

Pump-cutoff pressure is attained. Diaphragm reaches its uppermost position. Reservoir is now filled to its rated capacity.

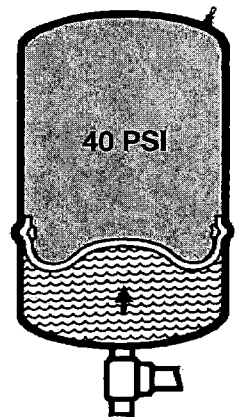

DELIVERY CYCLE*

Pump remains shut off while air pressure in top chamber forces diaphragm downward, delivering water to system.

PRE-PRESSURIZED DIMENSIONS AND WEIGHTS

	Model Number	Volume (Gallons)	Dimensions in Inches			Weight (lbs)
			"A" Overall Height	"B" To Center of Water Inlet	"C" Diameter	
ADX Series Free Standing	ADX-14	14.0	24-3/4	2-1/4	15-3/8	25.5
	ADX-20	20.0	32-3/4	2-1/4	15-3/8	30
	ADX-32	32.0	45-1/2	2-1/4	15-3/8	40
	ADX-36S	36.0	32-3/8	2-1/4	20	45
	ADX-52	52.0	38-5/8	2-1/4	23-3/8	77
	ADX-86	86.0	59	2-1/4	23-3/8	105
	ADX-96	96.0	63-3/8	2-1/4	23-3/8	111
	ADX-119	119.5	61-1/4	2-1/2	26	165
ADX Series In-Line	ADX-2	2.0	10-3/16	--	8-1/4	5
	ADX-5	4.6	14-3/4	--	11	9
	ADX-7	7.3	21-1/8	--	11	14
ADXH Series Horizontal				"B" Overall Length		
	ADXH-7	7.3	12-7/8	21-1/8	11	16
	ADXH-14	14.0	17-3/8	21-3/4	15-3/8	25-1/2
	ADXH-20	20.0	17-3/8	27-1/8	15-3/8	30

ADX-14, ADX-20, ADX-36S connection 1" Female.
 ADX-52, ADX-86, ADX-96, ADX-119 connection 1- 1/4" Female.
 In-line connection 3/4" Male.
 ADXH-7 connection 3/4" Male. * ADXH-14, ADXH-20 connection 1" Male.

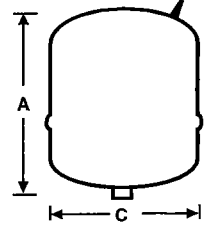
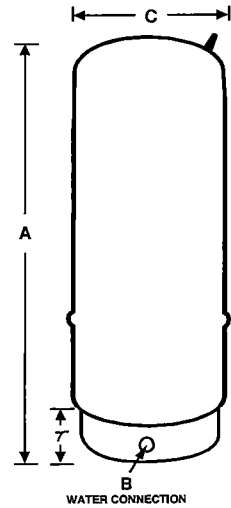
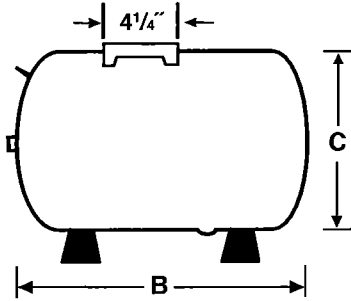
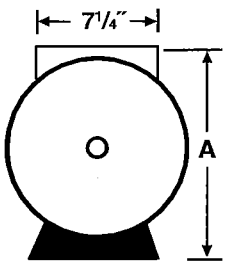

Certified to NSF/ANSI
61-G and 372



Export Pump Tanks

PUMP TANK SIZING

FREE-STANDING SELECTION CHARTS

The charts below allow you to easily select the right free-standing tank for standard size pumps between 2-1/2 and 30 gallons in capacity and for 20-40 psi, 30-50 psi and 40-60 psi pressure ranges. Minimum run times shown (from start-up) are 1 minute, 1-1/2 minutes and 2 minutes. For example, for a system that delivers 10 gpm at 30-50 psi, with a minimum run time of 1 minute, Chart 1 indicates that the proper tank is the ADX-36S.

Chart 1-ADX Series Free-Standing Tank Selection Chart

Pump GPM	System Pressure Ranges-PSI								
	20-40			30-50			40-60		
	Minimum Run Times (Minutes)								
	1	1-1/2	2	1	1-1/2	2	1	1-1/2	2
2.5	ADX-14	ADX-14	ADX-14	ADX-14	ADX-14	ADX-20	ADX-14	ADX-20	ADX-20
5	ADX-14	ADX-20	ADX-36S	ADX-20	ADX-36S	ADX-36S	ADX-20	ADX-36S	ADX-52
7	ADX-20	ADX-36S	ADX-52	ADX-36S	ADX-36S	ADX-52	ADX-36S	ADX-52	ADX-86
10	ADX-36S	ADX-52	ADX-86	ADX-36S	ADX-52	ADX-86	ADX-52	ADX-86	ADX-86
12	ADX-36S	ADX-52	ADX-86	ADX-52	ADX-86	ADX-86	ADX-52	ADX-86	ADX-96
15	ADX-52	ADX-86	ADX-86	ADX-52	ADX-86	ADX-119	ADX-86	ADX-96	ADX-119
20	ADX-86	ADX-86	ADX-119	ADX-86	ADX-119	[2]ADX-86	ADX-86	ADX-119	[2]ADX-86
25	ADX-86	ADX-119	[2]ADX-86	ADX-86	[2]ADX-86	[2]ADX-86	ADX-96	[2]ADX-86	[2]ADX-96
30	ADX-86	[2]ADX-86	[2]ADX-86	ADX-119	[2]ADX-86	[2]ADX-119	ADX-119	[2]ADX-96	[2]ADX-119

Chart 2- Drawdown Volume Multiplier (Approximate)

Pump Shut-Off Pressure psi	Pump Start-Up Pressure-PSI							
	10	20	30	40	50	60	70	80
20	0.26							
30	0.41	0.22						
40		0.37	0.18					
50		0.46	0.31	0.15				
60			0.40	0.27	0.13			
70			0.47	0.35	0.24	0.12		
80				0.42	0.32	0.21	0.11	
90				0.48	0.38	0.29	0.19	0.10
100					0.44	0.35	0.26	0.17

Chart 3- Drawdown in Gallons

Model No.	Vol. in Gallons	20-40	30-50	40-60
ADX-2	2.0	0.7	0.6	0.5
ADX-5	4.6	1.7	1.4	1.2
ADX-7	7.3	2.7	2.3	2.0
ADX-14	14.0	5.2	4.3	3.8
ADX-20	20.0	7.4	6.2	5.4
ADX-32	31	11.4	9.6	8.4
ADX-36S	36.0	13.3	11.2	9.7
ADX-52	52.0	19.2	16.1	14.0
ADX-86	86.0	31.8	26.7	23.2
ADX-96	96.0	35.5	29.8	25.9
ADX-119	119.5	44.2	37.0	32.3

7W

IF PROPER TANK SELECTION CANNOT BE MADE USING CHART 1, FOLLOW THIS PROCEDURE:

First find the "drawdown multiplier" by matching the pump start-up and shut-off pressures on Chart 2. For example, the multiplier for a 30-50 psi pressure range is .31. Next, insert the pump GPM capacity and desired minimum run time into this formula:

$$\frac{\text{PUMP GPM} \times \text{Min. Run Time}}{\text{Multiplier}} = \text{Minimum Tank Volume Required}$$

To assume dependable Drawdown Volumes, and in keeping with present industry practice, Drawdowns are based on Boyles Law.

For example, using a 10 GPM pump, a one-minute minimum run time, and a 30-50 psi pressure range, the formula is as follows:

$$\frac{10 \times 1}{.31} = 32.25 \text{ Minimum Tank Volume}$$

W Then, using Chart 3, select the tank that has a minimum volume that meets or exceeds your minimum volume requirement, and supplies adequate drawdown at the required pressure range. Minimum drawdown equals Pump GPM x Minimum Run Time. Therefore, in the above example, select the ADX-36S 36-gallon tank. It provides adequate drawdown at 30-50 psi.

RULE OF THUMB SYSTEM SIZING

The following water requirements figures are based on averages accepted by the industry. They represent typical household and farm animal water use requirements. Generally speaking, a reliable daily average water requirement is 100 gallons per day per person.

Average daily farm animal requirements

Gallons/Day	
Horse, Mule, Steer	12
Cow-Dry	15
Cow-Milking	35
Hog	4
Sheep	2
Chicken/100	6
Turkey/100	20

Average household water requirements (GPM) using industry-accepted 7-minute peak demand cycle

No. of Bathrooms	Type of Water Using Fixtures Installed	GPM Required
1	Sink, Toilet, Lavatory Tub/Shower	7
1 1/2	Same as Above but with Automatic Washer	10
2-2 1/2	Same as Above but with Automatic Dishwasher	14
3-4	Same as Above	17

Average home water requirements based on industry-accepted 7-minute peak demand cycle

Unit	Flow Rate GPM	Requirement Gallons
Kitchen Sink	5	3
Toilet	4	5
Lavatory	4	2
Tub or Shower	5	35
Auto Wash Machine	5	35
Dishwasher	2	14
Garden Hose (1/2")	3	Depends upon cycle time
Lawn Sprinkler	3-7	
Water Softener	7	

TYPICAL INSTALLATIONS

For multiple installations, manifold size is critical. If you have questions about sizes call our Technical Engineering Services Department at 1-800-999-9515.

FREE-STANDING SERIES*

The standard installation, utilizing front entry, with gauge, relief valve and pressure switch installed in front of tank.

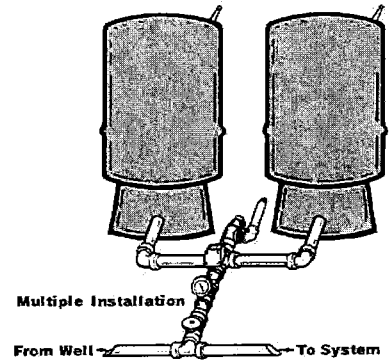
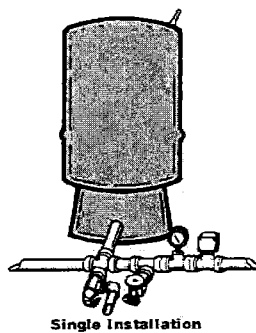

FREE-STANDING SERIES WITH PUMP MOUNTED ON TANK*

The pump can be mounted on tank using a universal mounting base. The pump and base can be strapped to the tank in the horizontal position, or mounted to the tank in a vertical position.

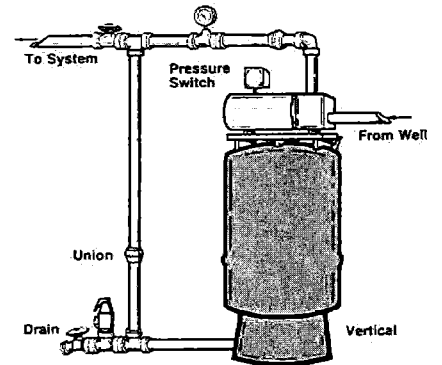
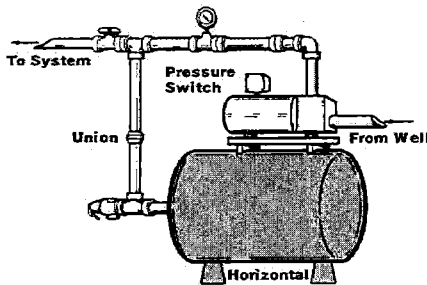

IN-LINE SERIES*

The In-Line Series is designed to be supported by system piping, either directly above the pump, or in a convenient place in the piping system as close to the pump as possible.

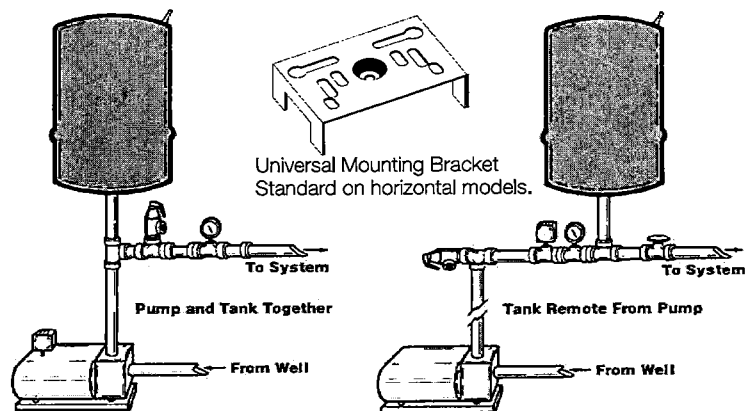

* When pump and tank are in different locations, the pressure switch should be at the tank location. Or compensating adjustment must be made for pressure loss due to head of water, i.e., one psi for every two feet of elevation.

PRESSURE RELIEF VALVE

ONLY FOR INSTALLATION ON PUMP TANK OR EXPANSION TANK SYSTEMS

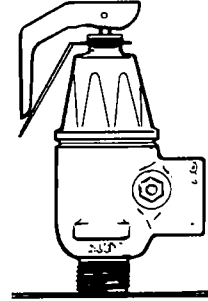
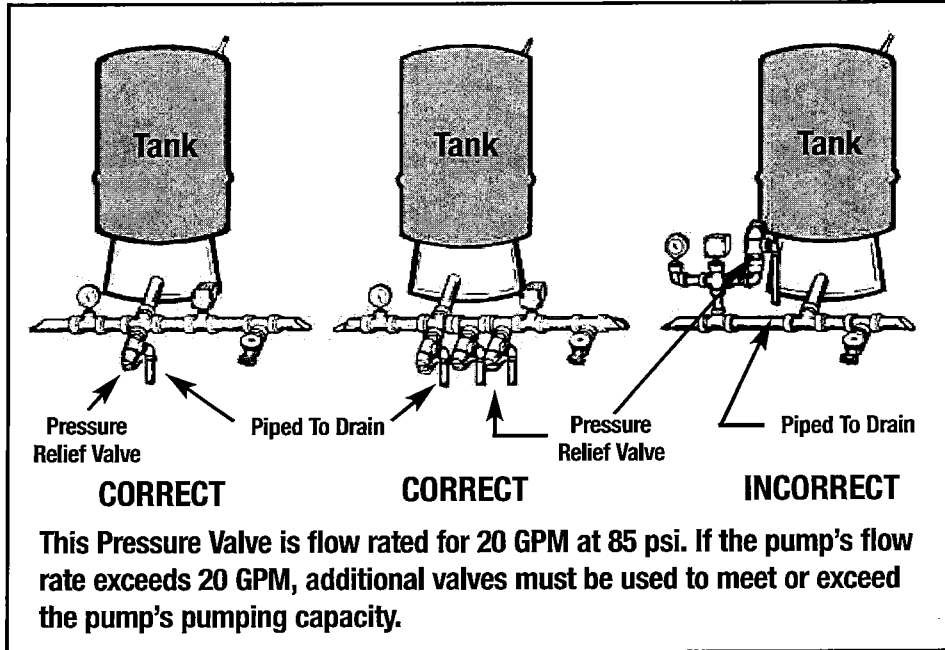

- 75 pound setting
- 20 GPM at 85 psi
- 3/4" male inlet size
- 3/4" female outlet size

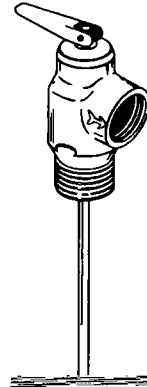

- 100 pound setting
- 20 GPM at 85 psi
- 3/4" male inlet size
- 3/4" female outlet size

Handwritten signature

For technical information call (800) 999-9515. American Water Heaters reserves the right to make product changes or improvements without prior notice.

For complete warranty information consult the written warranty of American Water Heaters found at: www.americanwaterheater.com or call (800) 999-9515 | Copyright © by American Water Heaters February 2016. All Rights reserved.



FDA APPROVED UV PROTECTION

●●● TRICAPA

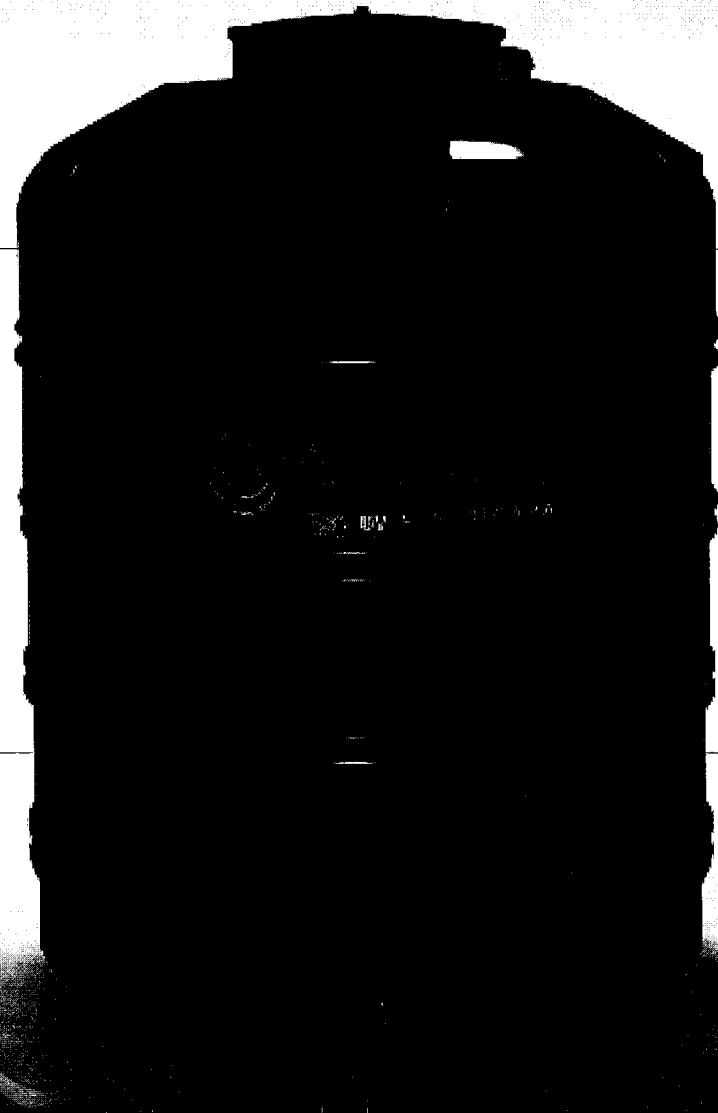

300 GLS

45" Diámetro

55" Altura



2,545 Lbs. Peso Lleno



FDA APPROVED UV PROTECTION

TRICAPA



410 GLS

50.25" Diámetro

51.75" Altura



3,489 Lbs. Peso Lleno

BEVÉ UV PROTECCIÓN TRICAPA

500 GLS

54" Diámetro
63" Altura
4,245 Lbs. Peso Lleno

TECNOLOGÍA ● ● ●
TRICAPA

Diámetro de la boca (17.9 pulgadas)

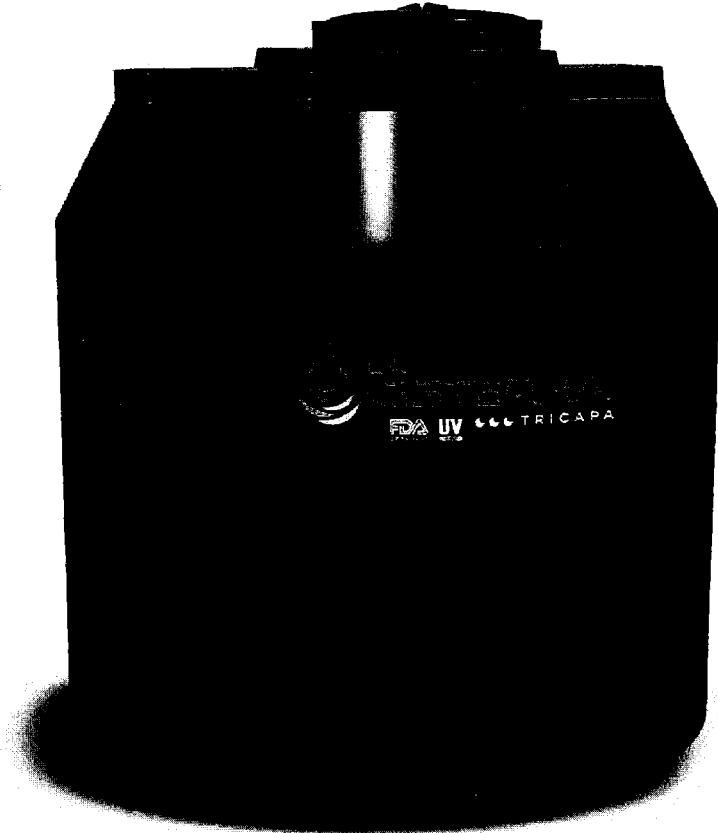

Distancia desde el conector hasta la entrada de agua (54 pulgadas)

Diámetro de la base (54 pulgadas)



CAPA EXTERNA

Resina resistente a los rayos UV, en color azul o blanca.



CAPA INTERMEDIA NEGRA

Resistente a los rayos UV que impide la transmisión de luz a la cámara del tanque. Esto evita la acumulación de algas.



CAPA INTERNA BLANCA:

Resina con protección UV aprobada por la FDA, para garantizar un interior antimicrobiano.

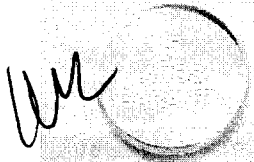



SCOPE OF WORK
PV Systems, Water Cisterns Acquisition, and Installation Services
Community Development Block Grant – Disaster Recovery
Puerto Rico Department of Housing
CDBG-DR-IFB-2021-01
(Revised for Contract Execution)

1. Introduction

The Puerto Rico Department of Housing (**PRDOH**) is issuing this Invitation for Bids (**IFB**) to acquire Photovoltaic Systems (PV Systems), Water Storage System Systems, and Installation Services for the **Community Energy and Water Resilience Installation Program (CEWRI)** under a contract with the PRDOH. This document defines the work the Selected Bidder must perform under a contract with PRDOH. The process is designed to promote fair and open competition while seeking a cost-competitive solution.

A detailed description of CDBG-DR Programs is included in the Action Plan approved by the U.S. Housing and Urban Development (HUD). A complete copy of the Action Plan is available at www.cdbg-dr.pr.gov/action-plan. CDBG-DR Program subject of this Scope of Work is briefly described below.

Program Overview

7W
The Community Energy and Water Resilience Installations Program (**CEWRI**) will provide homeowners, businesses, and/or public facilities energy and water efficiency improvements to promote resilience during emergencies with the installation of PV systems with battery back-up for critical loads and water storage system. The CEWRI program is intended to work with and complete existing CDBG-DR programs such as the Home Repair, Reconstruction, or Relocation Program (**R3**), the Social Interest Housing Program (**SIH**), and the Small and Business Incubators and Accelerators Program (**SBIA**).

This IFB is specifically intended for the equipment and installation of Photovoltaic System (PV Systems) and Water Storage System (WSS) for homes that have been repaired or reconstructed under the R3 and SIH CDBG-DR Program. We are defining homes as those involving the construction, alteration, or repair of single-family houses or apartment buildings of no more than four stories in height. Homes that do not fall under this category will not be serve under this IFB.

WZ
The PRDOH aims to contract, at its discretion and in the best interest of the program implementation, multiple firms for a term of 2 years with the option of an extension, up to one additional year. The acquisition of equipment and the required installation services will be made on an as-needed basis for the duration of the contract. No guarantee of the acquisition of any specific quantity or total dollar amount is made. The PRDOH reserves the right to increase or decrease amounts proposed on all goods/services. The PRDOH reserves the right to add or delete goods/services. Proposed quantities represent a reasonable estimate under this contract for bidding purposes. This IFB should be considered an "all or non-basis". Bidders must provide a bid for all goods and services

listed in this Scope of Work. Bidders must provide bids for equipment and installation of Photovoltaic System PV System, and Water Storage System.

The selected Bidder will be directly responsible for ensuring the accuracy, timeliness, and completion of all tasks assigned under this contract. Therefore, we encourage a careful analysis of the requirements of this document. The scope of work presented is based upon circumstances existing at the time the IFB is released. The selected Bidder must guarantee the prices of all the goods/services for the contract term. The PRDOH reserves the right to modify or delete the tasks/goods listed and, if appropriate, add additional tasks/goods before and during the term of the contract.

The PRDOH reserves the right, without limitations, to: (i) cancel this solicitation and reissue this IFB or another version of it, if it deems that doing so is in the best interest of the Public Interest; and (ii) amend the contract(s) of the Selected Bidder to, among others, extend its original duration, as further explained in this IFB, or to extend the scale of the scope to include work under subsequent CDBG-DR action plans as related to the services requested herein, including CDBG Mitigation (CDBG MIT) funds; and (iii) to contract one or more qualified bidders or the cancellation of this IFB.

2. Requirements

2.1 General Requirements:

- The Bidder selected to provide services regarding Photovoltaic System (PV System) must have a minimum of 5 years of experience within the renewable energy sector.
- The Bidder selected to provide services regarding Water Storage System (WSS) must have a minimum of 2 years of experience in installation of WSS.
- The Bidders offering services for both PV Systems and WSS shall satisfy both conditions above.
- All equipment to be supply and installed by the selected Bidder shall be new, no reconditioned, refurbished, or otherwise used parts or components will be accepted.
- All technical support or any warranty servicing from the manufacturers shall be generated and managed by the selected Bidder once contracted by the PRDOH.
- The selected Bidder shall not provide equipment that is close to the end of life or may become unsupported by the manufacturer during the required warranty period. If any equipment becomes unsupported by the manufacturer, the Bidder will be obligated to replace the equipment with an equivalent that meets the applicable warranty period, with similar or better specifications of the original, without incurring any additional financial obligation from PRDOH.

- All prices submitted by the Bidder shall include all expenses including incidentals, taxes, delivery fees, installation fees, profits, overhead, and any other administrative fees that apply to this acquisition. The PRDOH will not cover any additional costs. Only the unit price submitted for the equipment and installation services will be taken into consideration.
- The PRDOH will not be responsible for reimbursement or expense related to per-diem, tolls, parts or labors for equipment under warranty service.

2.2 Code Compliance:

- Installation and equipment shall comply with applicable building, mechanical, fire, seismic, structural, and electrical codes, included in the Joint Regulation for the Evaluation and Grant of Permits Related to Developments, Land Use, and Business Operations (Joint Regulation), as amended. Bidders must abide by the "Joint Regulation", as amended, "Regulation No. 7796", "Regulation No. 8080," and any other State regulation that regulates the installations within this Program.
- Bidder must install solar system equipment in compliance with Puerto Rico Residential Code 2018 (PRRC), National Electric Code (NEC), Puerto Rico Electrical Power Authority (PREPA) and Permit Management Office (OGPe, for its Spanish acronym) Regulations.

2.3 Contractor Responsibilities:

2.3.1. Contractor Levels

Contractors will be divided into Levels based on their financial capacity. The Contractor must select and comply one of the following Contractor Levels.

Level 1 Contractor

Level 1 Contractors will be those with high financial capacity which are able to perform high volume of task orders at any given time. Level 1 Contractors:

- Will have a higher financial capacity as defined in Section 6.1.8 Financial Information of the IFB;
- Will be frequently evaluated and held responsible for the performance of their team and organization, including designers, consultants, suppliers, manufacturers, and subcontractors;
- Will provide periodical status reports to PRDOH and its representatives; and
- Will attend or conduct meeting with the PRDOH and its representatives.

Level 2 Contractor

Level 2 Contractors will be those with moderate financial capacity which are able to perform moderate volume of task orders at any given time. Level 2 Contractors:

7W

MM

- Will have moderate financial capacity as defined in Section 6.1.8 Financial Information of the IFB;
- Will be frequently evaluated and held responsible for the performance of their team and organization, including designers, consultants, suppliers, manufacturers, and subcontractors;
- Will provide periodical status reports to PRDOH and its representatives; and
- Will attend or conduct meeting with the PRDOH and its representatives.

2.3.2. General Responsibilities

It is the responsibility of the selected Bidder to deliver quality services in compliance with the project requirements. Also, it is the responsibility of the selected Bidder to:

- Hold the correct permits and licenses necessary to conduct business in Puerto Rico and the city where the project is taking place, and the Bidder must have qualified and licensed personnel as required by the Puerto Rico government to perform PV Systems and/or WSS installations.
- The Designer for the PV Systems must be a licensed engineer in compliance with Puerto Rico's Act Number 173 of August 12, 1988, with the Renewable Solar Energy Installer (Photovoltaic) Certificate from the Public Energy Policy Program (PEPP) under the Department of Economic Development and Commerce (DDEC, for its Spanish acronym). Must have at least five (5) years of experience performing PV system design. Such designer will also be in charge of the Pre-Installation Assessment.
- PV Systems installers must be a professional with the Renewable Solar Energy Installer (Photovoltaic) Certificate from the Public Energy Policy Program (PEPP) under the Department of Economic Development and Commerce (DDEC, for its Spanish acronym).
- The Designer for the WSS must be a licensed engineer in compliance with Puerto Rico's Act Number 173 of August 12, 1988. Must have at least two (2) years of experience performing WSS design. Such designer will also be in charge of the Pre-Installation Assessment.
- Uphold a professional demeanor while on a job site.
- Coordinate with PRDOH selected Program Managers (PMs) with tasks related to this Scope of Work.
- Coordinate with the selected PM in order to Conduct a Pre-Installation Assessment. This will provide the Designer with the necessary data to perform the design and/or to determine what remediation will be needed for the installation.

700

MR

- Conduct a pre-award site visit. Assist the PMs during the applicant award process. The Bidder will be responsible for clarifying the owner any design-related clarification that might be needed.
- Perform a Pre-Installation Assessment site visit.
- Perform work after the corresponding reviews, approvals, and or notices to proceed are issued by the selected PRDOH Program Manager.
- Perform work as specified in accordance with all project requirements and all applicable laws and codes.
- Dispose of all materials in a safe manner in accordance with all local and federal regulations.
- Perform commissioning tests and correct any findings. Corrections will be paid by the Bidder, and PRDOH will not reimburse for them.
- Participate in closeout inspections and address findings.
- Work with PMs to ensure the project is completed within the project timeline and budget while minimizing disturbance.

7W

3. Photovoltaic System:

3.1 Pre-Installation Assessment:

The Bidder shall be responsible for the Pre-Installation Assessment of each project site where installation will be performed. A certified installer, a licensed professional engineer, and/or a licensed architect in Puerto Rico with the expertise of five years or more in the Photovoltaic system industry shall conduct the assessment. Assessment includes but is not limited to the following activities:

- Evaluate the property's roof capacity to support the PV system by completing a roof capacity checklist for home installations. The selected bidder will generate a scope of work based on the findings from the roof capacity checklist. A full evaluation shall provide information on roof load capacity, shading study, and other required studies to allow the system to function properly at the installation site. The Scope of Work generated shall detail the installation plan, on the roof of the dwelling unit to support its installation and full functionality.
 - Shading Analysis: Assess if the proposed array location supports a solar resource potential of more than 75 percent of the same site's optimal solar resource potential.
 - Assess the home's interior and exterior elements and determine their conditions to facilitate the installation of conduits and electrical equipment. Home interior and exterior elements may include (but is not limited to):
- UN

- Structural, electrical, plumbing, and HVAC systems installed in the roof;
 - Main panelboard
 - Branch circuits
 - Exterior Shade Element
 - Lightning protection
 - Electrical service entry including overhead wires, electric meter, service entry conductor
 - Other relevant components
- After examining the home's roof elements and determine their condition, other considerations may include (but are not limited to) home site elements:
- Site restrictions
 - Site accessibility
 - Yards and courts
- Structural analysis: Verify the roof's load capacity to support the equipment load, home's exterior elements, and determine their conditions. Home external elements may include (but are not limited to):
- Roof weatherproofing and covering including asphalt shingles, wood shingles or shakes, metal roofing, cement shingles, built-up roofing, single-ply membranes, and roll roofing, among others;
 - Skylights;
 - Gutters and downspouts; and
 - Parapets and gables.

The structural analysis shall be conducted by a licensed engineer with a structural engineer degree or studies.

- JW*
- Equipment Location
 - Determine the best locations for the PV System and all components as per designer and manufacturer's specification.
 - In the Pre-Installation Assessment report and Scope of Work, the selected Bidder must clearly define the location of the PV System and all components in accordance with applicable codes.

3.2 Design Service:

- Selected Bidder must design a standard photovoltaic system with battery back-up for single-family homes. System shall be capable of running critical loads, some household appliances (refrigerators, water pump, etc.), life support devices, and permit the occupants to shelter-in-place during electrical grid outages. Design should be standard, with minimal deviation to allow for consistency in cost across various single-family homes. The selected Bidder shall adhere to the following design guidelines:

WR

- 76
- A licensed professional structural engineer must certify that the existing roofs are structurally sound for the installation of the PV System and that the proposed system meets code requirement and the requirement of this IFB.
 - System layout shall meet local fire department, code, and ordinance requirements for roof access.
 - The PV System installation shall not interfere with roof drains, water drainage, expansion joints, air intakes, existing electrical and mechanical equipment, and existing antennas.
 - The system shall be directly attached to the roof unless the structural engineer deems the roof incapable of holding the PV System. If the structural integrity of the house does not support the load of the system, then, the applicant will immediately be ineligible for the PV System installation.
 - Racking Structure needs to be corrosion resistant and meet applicable local building code requirements concerning rain, wind, and earthquake factors.
 - All penetrations and structural connections associated with supports and conduit shall be kept to a minimum and shall be waterproof.
 - All roof penetrations shall be designed and constructed in collaboration with a roofing professional or manufacturer responsible for the roof and roofing material warranty for the specific site. All roof installations and weatherproofing of penetrations shall not compromise the roof warranty, or if the roof has no warranty, accepted best practice. The roof penetration and roof connections shall be warranted for weather tightness from the installer, including parts and labor (see Section 7 in this document for warranty details). The roofing contractor shall provide a warranty letter specifying that the roofing impermeabilization warranty is still in effect after the installation of the PV System.

3.3 Award Visit:

Refer to Section 5 Other Tasks applicable for services of PV System and Water Storage System, for additional information.

3.4 Permits

The selected Bidder shall obtain all required permits and licenses for the project. Also, the selected Bidder shall be responsible for any certification and/or notification to the applicable state agencies regarding the services to be provided to each project, including interconnection certifications and fees in accordance with the Act 17 of April 11 of 2019 ("Ley de Política Pública Energética de Puerto Rico"). All fees associated with the permits, notifications, and licenses are the responsibility of the selected Bidder.

77

Any additional documentation required, or corrections of deficiencies identified by PREPA or any other permitting agencies, after the certification and notification

required by the Program, must be addressed and brought to a conclusion by the Bidder at no additional cost to PRDOH.

3.5 PV System Installation Service:

- Selected Bidder shall be responsible for acquiring all permits and endorsements for system installation, system operation, and system interconnection in accordance with Act 17 -2019 ("Ley de Política Pública Energética de Puerto Rico").
- Installation of PV System- selected Bidder shall supply, install, and commission the PV System. Installation costs shall be standardized to accommodate installation across various types of single-family homes. System shall only be installed at sites with at least an 75% solar access, systems shall not be installed on roofs with significant shading. If the site does not have at least an 75% solar access, then, the applicant will be ineligible for the PV System installation. Inverters and batteries shall be installed in a shaded location and shall not be exposed to direct sun light.
- Install materials following the manufacturer's requirements.
- Provide all labor, materials, tools, equipment, and services required to complete the project as specified.
- Responsible for the cost of all items required for a complete and operating system.
- The selected Bidder shall be obligated to maintain a torque log of the installations, following designers' specifications.
- No material should be installed if:
 - Materials are not compatible with existing conditions.
 - Installation of materials violates equipment warranty.
 - Installation is not to code or industry standard.
 - Such are not in compliance with the conditions established by the program, federal or state regulations or this IFB.
- The PV System installations shall follow the best installation practices described by the National Renewable Energy Laboratory (NREL) in the following documents or any other industry related document:
 - Solar Photovoltaic in Severe Weather: Cost Consideration for Storm Hardening PV Systems for Resilience
 - Solar Photovoltaic Systems in Hurricanes and Other Severe Weather

The United States Department of Energy Guidance's mentioned above are included as an attachment to this IFB.

7W

MM

3.6 Commissioning

- Perform commissioning and Inspection following the International Electrotechnical Commission (IEC) standard IEC 62446, any local or state regulation, program requirements, and correct any finding. The commissioning should verify that the project is performing as per project design.
- The designer shall perform commissioning of the entire PV system. This data shall be used to confirm the proper performance of the PV system. Performance tests shall be conducted at the final commissioning/acceptance testing. A digital copy of the commissioning report must be uploaded into Canopy and/or any other PRDOH management tool. A second system re-commissioning is mandatory at the end of the first year of operation. A commissioning report will be provided to PRDOH. In the event of a re-commissioning test failure, the Bidder will be responsible for the corrections, repairs, and proper functioning of the system.

3.7 Inspection

Refer to Section 5 Other Tasks applicable for services of PV System and Water Storage System, for additional information.

3.8 Technical Specifications for PV systems:

- 7W
- The program offers standard packages for PV systems and battery storage based on the following two scenarios:
 - **Scenario #1:** For dwelling units with a refrigerator that consumes 489 kWh/yr or less, the following package will be installed. A standard package of a required system minimum of **3kW DC¹** PV modules with a minimum Battery bank voltage of **48V²** and a required battery bank output of a minimum of **9 kWh³** with an **autonomy of 20 hours**; loads also includes one medical life support device. The required battery chemistry is Lithium-Ion.
 - **Scenario #2:** For dwelling units with a refrigerator that consumes over 489 kWh/yr, the following package will be installed. A standard package of a required system minimum of **4.3 kW DC** PV modules with a minimum Battery bank voltage of **48V** and a required battery bank output of a minimum of **12.8 kWh** with an **autonomy of 20 hours**; loads also includes one medical life support device. The required battery chemistry is Lithium-Ion.

Both standard packages shall have the capability of supplying electricity to an itemized list of devices, appliances and lighting fixtures identified as critical loads. The system will supply electricity to the critical loads independently as a

¹ kW stands for kilowatt and DC for direct current.

² V stands for voltage.

³ kWh stands for kilowatt hour.

stand-alone system, with the capability of interconnecting with the grid. For the purpose of the CEWRI Program, the Bidder must submit to PREPA the Interconnection package. Nevertheless, the approval of the Interconnection by PREPA will not be required for the closeout of the case.

- Systems shall be capable of running critical electrical loads, some household appliances and equipment (refrigerators, lighting, water pump, etc.), life support or medical devices, and permit shelter-in-place occupants' ability during electrical grid outages. Design should be standard, with minimal deviation to allow for consistency in cost across various single-family homes. In the event of a power outage, the protected appliances, tank's water pump, medical devices, and any load connected to the PV and battery back-up system will continue to work with no disruptions.
- The selected Bidder shall perform all professional services as necessary to provide applicants with a complete design of the proposed project. The system shall be designed and engineered to maximize the solar energy resource, considering the residents' electrical demand and load patterns, proposed installation site, and available solar resource. After concurrence of a final design by PRDOH's Program Manager, the selected Bidder shall provide all necessary materials, equipment, and labor to complete the PV System installation and interconnection with the electrical grid in accordance with Act 17 of April 11 of 2019 ("Ley de Política Pública Energética de Puerto Rico").
- The selected Bidder shall also provide and install a manual transfer switch to allow for system operation in standalone mode.
- The selected Bidder shall also provide to the applicant written instructions and procedures for shutdown and start-up activities for all system components.
- Photovoltaic (PV) Modules
 - PV modules shall be a commercial off-the-shelf product, must be OGPe Certified.
 - PV modules shall have a 25-year limited warranty that modules will generate no less than 80 percent of rated output under Standard Test Conditions (STC). PV modules that do not satisfy this warranty condition shall be replaced.
 - Modules shall be through-bolted to the underlying racking; top down clamps shall not be used under any circumstances, unless the designer specify the contrary.
 - The PV system shall be physically attached to the building roof and tilted at 5 to 10 degrees to the south.
- Inverter(s)
 - Inverters shall be a commercial off-the-shelf product,
 - The inverter shall have at a minimum the following features:

700

1111

- OGPe Certification
- UL/ETL⁴ listed
- Peak efficiency of 96 percent or higher
- Inverter shall have operational indicators of performance and have built-in data acquisition and remote monitoring.
- Warning labels shall be posted in compliance with local and federal regulations
- Operating instructions shall be posted on or near the system and on file with facilities operation and maintenance documents.
- Provide detailed instructions on how to turn of the equipment.
- The inverter shall be 120/240 V split phase.
- The inverter must provide a Pure Sine Wave.
- Electrical Wiring
 - Areas where wiring passes through ceilings, walls, or other areas of the residence shall be adequately restored, booted, sealed, and returned to their original condition.
 - It is mandatory to include a subpanel for the critical loads served by the PV with battery inverter System.
- Structural Components
 - All structural components shall be non-corrosive (preferably marine stainless steel or aluminum). All hardware shall be marine stainless steel or aluminum. All components shall be designed to obtain a minimum 20-year design life.
 - All connections shall be bolted and torqued to specified value. Under no circumstances shall clamping systems or self-tapping sheet metal screws be used to hold:
 - Underlying structural frame members together
 - Module frame to underlying structural frame member
- Back-Up Storage System
 - The required battery chemistry is Lithium-Ion.
 - The required battery bank voltage is 48 V.

4. Water Storage System (WSS):

4.1. Pre Installation Assessment

The designer shall be responsible for the Pre-Installation Assessment of the projects to be performed a service. A certified installer, a licensed professional engineer, and/or licensed architect in Puerto Rico with the expertise of five years or more in the construction industry shall conduct the assessment (except for the load analysis, which must be performed by a licensed professional structural engineer). Such task includes but is not limited to the following activities:

⁴ Acronyms stand for the following respectively: Underwriters Laboratory/Electrical Testing Laboratories

- Evaluate the property's roof's capacity to support the WSS system by completing a roof capacity checklist for home installations. The selected bidder will generate a scope of work based on the findings from the roof capacity checklist. A full evaluation should provide information on roof load capacity and all required analysis to allow the system to function properly at the installation site. The Scope of Work generated shall detail the installation plan, on the roof of the dwelling unit to support its installation and full functionality.
- Assess if the proposed equipment can be located on the rooftop without interfering with the other equipment mounted and/or to be mounted on it.
- Assess the home's interior and exterior elements and determine their conditions to facilitate the WSS components installation. This assessment should be included within the PV System assessment whenever possible. Home interior and exterior elements may include (but are not limited to):
 - Structural, electrical, plumbing, and Heating, Ventilation, and Air Conditioning (HVAC) systems installed in the roof;
 - Main panelboard
 - Any electrical conduit that might interfere with the WSS components installation.
- After examining the home's roof elements and determining their condition, home site elements shall be examined which include (but are not limited to):
 - Site restrictions
 - Site accessibility
 - Yards and courts
- Verify the roof's load capacity to support the equipment load, home's exterior elements, and determine their conditions. Home external elements may include (but are not limited to):
 - Roof weatherproofing and covering including asphalt shingles, wood shingles or shakes, metal roofing, cement shingles, built-up roofing, single-ply membranes, and roll roofing, among others;
 - Skylights
 - Gutters and downspouts
 - Parapets and gables
 - Lightning protection
 - Electrical service entry including overhead wires, electric meter, service entry conductor

 **4.2. Design Service:**

Selected bidder must design the Water Storage System for single-family homes following the requirements stated in Section 4.6 of this Scope of Work (Technical Specifications for the Water Storage System).

4.3. Award Visit:

Refer to Section 5 Other Tasks applicable for services of PV System and Water Storage System, for additional information.

4.4. Water Storage System Installation Services

- Selected Bidder shall be responsible for acquiring all equipment and be responsible for its installation.
- Selected Bidder shall be responsible for all permits and endorsements for system installation (as required).
- Installation of Water Storage System- Selected Bidder shall install the Water Storage System. Installation costs shall be standardized to accommodate installation across various types of single-family homes.
- Install materials following the manufacturer's requirements. The Selected Bidder must coordinate with PV system installers to make sure the water pump is connected to a PV standalone electrical system circuit (as required).
- The water pump shall not shade or otherwise obstruct to the photovoltaic modules.
- Provide all labor, materials, tools, equipment, and services required to complete the project as specified.
- Responsible for the cost of all items required for a complete and operating system.
- No materials shall be installed if:
 - Materials are not compatible with existing conditions.
 - Installation of materials violates equipment warranty.
 - Installation is not to code or industry standard.
 - Materials are not in compliance with the conditions established by the program, federal or state regulation or this IFB.

4.5. Inspection:

Refer to Section 5 Other Tasks applicable for services of PV System and Water Storage System, for additional information.

4.6. Technical Specifications for Water Storage System: The selected Bidder shall obtain all necessary equipment, materials, design, and testing services for the installation of the WSS. The system shall:

- Provide domestic water to the home from the water storage tank using an electric water pump, controls and a diaphragm type pressurized tank to provide back-up water supply to the domestic water line. Tank should be sized to meet water needs of the home by providing an adequate level of pressure without damaging water fixtures. The WSS shall supply each household at least two days of potable water supply during a disaster scenario.
- If the roof structure allows, the water storage tank shall store a maximum capacity of 500 Gallons per household, complete with all its necessary accessories and instrumentation for full functionality of water storage and distribution within the home during a disaster scenario. The capacity of the tank should be defined by the designer according to the household needs. The water storage tank shall be connected to the utility's main water line with a water level control valve and backflow preventer designed to prevent backflow from the water storage tank to the utility main water line. The water storage tank shall have instrumentation to monitor and control pressure and water level.
- The water storage tank shall be located on the rooftop of the home. If the structural integrity of the house does not support the load of any of the applicable water tank size options, then, the applicant will immediately be ineligible for the WSS installation.
- In case the house loses power, the electric pump should be able to work off-grid from the main electrical utility supported by the PV and battery system granted to the applicant from the CEWRI program, when applicable.
- The water storage tank shall be constructed of ultraviolet (UV) and corrosion resistant material, approved for potable water, and have the Food and Drug Administration (FDA) and the National Safety Foundation (NSF) approval.
- Other related material for complete installation should include but is not limited to:
 - Pump: ½ horsepower with pressurized tank
 - Diaphragm type pressurized tank should be sized to provide adequate pressure to meet the water demands of the home.
 - Piping: Only copper piping is authorized. Sediment filter: Should be able to filtrate 10 microns particles.
 - Sensor level: Recommended use whenever possible.
 - Install a Buoy
 - Backflow prevention system to prevent cross-connection between household water system and water main.
 - The water storage tank must be watertight and intended for potable water use.

760

W

- All water storage tanks must be specifically manufactured for potable water use in accordance with FDA food-grade specifications, NSF standards, or other nationally recognized standards for potable water. Documentation from the manufacturer stating that tanks are approved for potable water must be available for inspection. Water Storage tanks must be installed according to the manufacturers' specific instructions.
- All water storage tanks must be vented to allow the free flow of air into and out of the tank as the water level inside the cistern changes. The vent opening must be turned down and must be screened with a 24-mesh screen cloth to prevent the entry of insects, birds, and other animals.
- Connect to water utility main to provide continuous flow of water through the water storage tank.
- Before filling and using, the water storage tank and pressure tank must first be cleaned and disinfected.
- Disinfection of the water storage tank and pressure tank after installation is mandatory, and the selected Bidder must follow the manufacturer's recommendation for potable water systems.

7W

5. Other tasks applicable for services of PV System and Water Storage System:

5.1. Pre-Installation Assessment Visit, Report, and Case Work Orders

- Perform a Pre-Installation Assessment visit to each dwelling units and develop the Pre-Installation Assessment report for each case project. Submit report to the PMs for approval.
- Develop case Scope of Work for each project. Submit scope of work to the PMs for approval.

5.2. Award Visit:

The Selected Bidder will perform the following tasks during the award visit including but not limited to:

- Perform award visit with the PMs to each applicant's property to complete the Project Grant Agreement.
- Perform orientation to Applicants of the measures that are being offered and that may be installed in the unit.
- Ensure that the applicant is informed on the process, the works to be performed, and the conditions of the award prior to any work being performed.
- Assist the PMs during the applicant award process. The Bidder will be responsible for clarifying the owner any design-related clarification that might be needed.

MM

5.3. Inspection

The Selected Bidder will visit the project site along with the PRDOH Program Manager and inspect works for overall quality standards. Upon completion of the installation, PM's Inspector will perform an inspection of the physical installation, as well as all paperwork submitted by the selected Bidder. Once on-site, the PM's Inspector shall ensure that all contractually agreed upon work was completed and confirm:

- That the equipment installation is in accordance with the design and installation drawings and specifications.
- That the model of the equipment installed is in accordance with the designer's specifications.
- Quality workmanship of installation.
- A brief review of findings as compared to the initial description of the site, scope of work, any change order(s) and final invoice.
- All warranties are included and active.

7W
During the post-install site inspection, the Inspector will record any corrections to the installation that need to be made by the selected Bidder. If, during the post-installation inspection, the Program finds discrepancies between the work performed and the scope of work, installation standards and/or equipment specifications, the selected Bidder will be responsible, at the selected Bidder's expense, for bringing the installation into conformance before the selected Bidder is paid. Installation corrections, as noted during final acceptance or the post-installation inspection, shall be performed within ten (10) business days. If the selected Bidder cannot undertake corrective actions within ten (10) business days, the Selected Bidder shall deliver to the PM, in writing, reasons for the delay. PM shall determine validity and allow for a delay no longer than twenty (20) calendar days after validity is determined. Any discrepancies or disagreements between PM and selected Bidder shall be escalated to the adjudicating official within PRDOH.

5.4. Orientation and Training to Applicants

- The Selected Bidder shall perform orientation and training to the Applicants regarding operation and maintenance of the installed systems and equipment.
- Selected Bidder must deliver all applicable Operation and Maintenance Manuals of the installed systems to each Applicant receiving a system along with any other required documents.

5.5. Health and Safety:

UM
The Selected Bidder shall observe and comply with all applicable laws, ordinances, codes, and regulations of governmental agencies, including federal, state, municipal, and local governing bodies having jurisdiction over any or all of

the scope of services, including all provisions of the Occupational Safety and Health Act of 1979 as amended, and all other applicable federal, state, municipal and local safety regulations. All services performed by the Selected Bidder must be in accordance with these laws, ordinances, codes, and regulations. The Selected Bidder shall release, defend, indemnify and hold harmless the PRDOH, its officers, agents, volunteers, and employees from all damages, liability, fines, penalties, and consequences from any non-compliance or violation of any laws, ordinances, codes, or regulations. Additionally, the following requirements must be met:

- The Selected Bidder must develop and submit to the PMs a safety plan for approval.
- Provide a statement of how your firm will be prepared to work within the project timeline and on time, ensure conformance with quality control standards, and respond to quality control issues during and after completing the project.
- Develop, monitor, and implement health and safety policies as to ensure that projects follow health and safety laws and regulations, in order to reduce or prevent hazards, dangers, and accidents.
- All roof access points shall be securely locked at the end of each day.
- Suppose a release of hazardous materials or hazardous waste that cannot be controlled occurs connected with this contract's performance. In that case, the Selected Bidder shall immediately notify the appropriate public safety service (police, fire rescue, or emergency medical services), PRDOH Program Director, and project designees. The Selected Bidder shall not store hazardous materials or hazardous waste without proper permits.

5.6. Damage and Disposal:

The Selected Bidder shall proceed with work in a manner that does not damage existing materials/infrastructure unless otherwise directed by Organization:

- The Selected Bidder shall document pre-existing damage to the materials/infrastructure and report any such damage to the PMs.
- The Selected Bidder shall repair at its expense damage to buildings and equipment caused by this project's work.
- The Selected Bidder shall remove all materials, equipment, and debris immediately upon completion of the project or at the end of each workday (unless the dwelling unit owner agrees to provide storage space).
- The Selected Bidder shall keep access to all areas of the dwelling unit clear.
- The Selected Bidder shall not use on-premise refuse containers for disposal of any material whatsoever without prior approval of CEWRI PMs.
- The Selected Bidder shall protect people and property from damage and debris at all times during the construction process.

5.7. Hazardous Material Clean-Up:

All surfaces and articles contaminated by hazardous materials during this work shall be cleaned in accordance with all applicable laws, codes, and ordinances and be transported safely to the appropriate destruction/servicing facilities. The Selected Bidder shall comply with the regulations to manage hazardous waste as specified in the [applicable state code].

5.8. Reporting

The selected Bidder should be responsible for the creation and submission of the following reports to the CEWRI Program Manager:

- Pre-Installation Assessment Report
- Systems Installation Report
- Project Commissioning Report
- Pre-Inspection Package documentation in support to the requested CEWRI Inspection to ensure that current works performed merit the Final Inspection. If documentation submitted to the Program Manager does not merit a Final Inspection, the Program Manager shall deny the Final Inspection request to the PRDOH PV system and water storage system contractor and state the reasons as to why the CEWRI Inspection was denied.

6. Warranty: Selected Bidder shall warrant all its products for the following period:

- **Ten (10) years** guarantee for the Solar Photovoltaic System Panels.
- **Twenty-five (25) years** of Linear Performance Guarantee for the Solar PV modules.
- **Ten (10) years** guarantee on Battery Bank and inverter.
- **Five (5) years** for the WSS.

Warranties shall include:

- Parts, labor, faulty material, manufacturing defects, defective items, emergency works of the systems and installation costs related to the failure of equipment under warranty (when due to equipment failure during the warranty period during the ten years of operation for PV system and five years of operation for the WSS).
- Repair or replacement of all system components for both systems, including but not limited to faulty material, manufacturing defects, during the warranty period.
- All unscheduled or emergency warranty works must be completed within (7) seven days of notification to Selected Bidder from the homeowner at no

additional cost to PRDOH or the homeowner during the warranty period. If the 7-day period is not enough due to equipment shortage, the selected Bidder must provide a written explanation and a copy of the equipment's delivery documents.

- Full warranty documents for all installation shall be submitted to the Applicants and in duplicate to the CEWRI PMs firm.

After full payment for the installation, no further costs will be paid by PRDOH

7. **Deliverables:** The key deliverables to be provided include, but are not limited to, the following:

- Selected Bidder must submit monthly reports to CEWRI Program Manager and PRDOH. Monthly reports shall be due the fifth (5th) day of each month and shall include:
 - Copies of all notifications from CEWRI PMs
 - Inspection orders placed within previous calendar month and inspection reports, as applicable.
 - Notices to begin the design phase within the previous calendar month
 - Notices of accepted/rejected designs within previous calendar month
 - Locations of all pending and completed tasks within the previous calendar month.
 - Explanation of pending and completed design tasks within the previous calendar month.
 - Explanation of pending and completed installation tasks within the previous calendar month.
 - Copies of all payment requests sent to PM within the previous month.
 - Payment receipt notifications with the date payment was received.
- Selected Bidder must develop and submit to the PMs the following but not limited to:
 - Pre-Installation Assessment Visit and Report for each project
 - Case Scope of work for each project.
 - System Designs for each Projects
 - Systems Installation Report
 - Commissioning Report
 - All technical documentation, including Components data sheets and listing
 - Warranties
 - Installation and operation manuals
 - As-built version of system drawings, cable lists and routing, wirings, grounding system,
 - Any other documentation required or requested by PRDOH.

7W

W

8. Delivery Schedule

- Coordinate with Applicant and CEWRI Program Manager for any pre-installation assessment visits, installation, and closeout inspections.
- Upon notice from the CEWRI PM firm, the selected Bidder shall, within three (3) working days, perform the pre-installation assessment and report.
- Upon notice from the CEWRI PM firm, the selected Bidder shall, within six (6) working days, perform the design of the project and submission of the Interconnection Package to PREPA.
- Upon notice from the CEWRI PM firm, the selected Bidder shall, within seven (7) working days, install the system(s), perform the commissioning of the project, and submission of the Pre-Inspection Package. If the 7-day period is not enough due to equipment shortage, the selected Bidder must provide a written explanation and a copy of the equipment's delivery documents.
- Upon completion of installation, Selected Bidder shall submit the official payment request to CEWRI PM with all applicable documentation, including warranty. Warranty documentation shall be submitted in duplicate (one for PM/PRDOH and one for the homeowner/applicant) Selected Bidder is responsible for delivering warranty information to the homeowner/applicant.

7W

9. Terms and Conditions

The following terms and conditions are designed to state expectations relating to the project and the selected Bidder's work performed. Should the Selected Bidder deviate from these standards and guidelines, all costs and liability associated with the observed deviation will be the Selected Bidder's sole responsibility.

9.1. Interpretation of Scope of Work:

The selected Bidder is responsible for reading and fully understanding the scope of work. The design-build approach allows for continual collaboration; however, any proposed changes to the original proposal must be approved in writing by the Selected Bidder and PM through the change order process before proceeding.

9.2. Existing Conditions:

The selected Bidder is responsible for verifying the installation site's existing conditions as reported in this Invitation for Bids before construction begins.

9.3. Installation Schedule:

The selected Bidder will complete the installation within the timeline described in **Section 9**. Once the installation has begun, the selected Bidder is required to be on-site every day during regular business hours (or at a time pre-arranged with PRDOH) for the full work period until the installation is complete.

W

- The selected Bidder shall have all required materials in stock prior to beginning installation.
- The selected Bidder shall give the PMs an estimate of the date the installation will be completed and shall inform the PMs if the installation appears to be taking longer than the original estimate.
- Corrections as identified during final acceptance or as a result of the quality control process shall be performed within ten (10) business days unless the problem interrupts PRDOH normal business operations or presents a health and safety threat, in which case the correction shall be made immediately. Exceptions to this rule shall be granted in circumstances beyond the control of the Selected Bidder (e.g., unforeseen existing conditions, material backorders, etc.). The selected Bidder shall notify PRDOH (verbally and in writing) that the correction will or may violate this provision.

7W

9.4. Communication:

The selected Bidder shall respond to information requests within two (2) business days. Response form will be determined by the request. The response may be in the following forms but not be limited to: E-mail, hardcopy, fax.

9.5. Change Orders and Scope of Work Modification:

The contract may be increased or decreased after the proposal is accepted. Under no circumstances shall the selected Bidder deviate from the work defined in the scope of work without advance written approval from PRDOH.

9.6. Final Acceptance:

A project will not be considered complete until all project steps are completed, including quality control inspection, training, and all project deliverables.

END SCOPE OF WORK

MM



**Exhibit O-1
COST FORM
Invitation for Bids
PV Systems, Water Cisterns Acquisition and Installation Services
Community Development Block Grant – Disaster Recovery
CDBG-DR-IFB-2021-01
(Revised for Addendum No. 6)**

Name of Proposer: Synerlution Energy, LLC (Synerlution, Inc.)

Cost Form 1. Unit Pricing

Equipment Description ⁽¹⁾	Price per Unit
Photovoltaic (PV) System with Battery Storage and related Services⁽⁵⁾⁽⁶⁾	
Cost per Watt (\$/W DC)	\$6.59
Water Storage System (WSS) and related Services⁽⁴⁾⁽⁵⁾⁽⁶⁾⁽⁷⁾	
300 gallons WSS	\$5,000.00
350 gallons WSS	\$5,300.00
400 gallons WSS	\$5,300.00
450 gallons WSS	\$5,400.00
500 gallons WSS	\$5,400.00

7W

Notes

- (1) All equipment to be submitted with the Bid to comply with the specifications for such included in the Scope of Work.
- (2) Bidder shall submit technical/specification documentation for all equipment offered as part of the bid.
- (3) All equipment offered as part of the bid is subject to the Warranty conditions set forth in the Scope of Work.
- (4) Bids which do not contain pricing for every item requested will be considered unresponsive by the PRDOH.
- (5) Pricing must include all services associated with the PV System and WSS included in the Scope of Work.
- (6) Pricing must include all expenses, including incidental, taxes, handling, and delivery costs, as well as any other administrative costs associated with the goods and services. The PRDOH will not consider any additional costs. Only the unit prices submitted will be taken into consideration. The PRDOH will not be responsible for reimbursement of expenses related to per-diem, tolls, parts, or labors for equipment under warranty.
- (7) Bidders shall provide the pricing for water storage systems inclusive of a 0.5 horsepower (hp) water pump with a pressurized tank and copper tubing/connections.

AK

Name of Proposer: Synerlution Energy, LLC (Synerlution, Inc.)

Cost Form 2. System Pricing

Equipment Description ⁽⁸⁾	Price per Unit	Qty. ⁽¹⁶⁾	Total
PV System with Battery Storage and related Services⁽¹¹⁾⁽¹²⁾⁽¹³⁾			
3 kW DC with 9kWh/day Battery Storage	\$20,300.00	1,075	\$21,822,500.00
4.3 kW DC with 12.8 kWh/day Battery Storage	\$25,500.00	72	\$ 1,836,000.00
[A] Sub-Total PV System			\$23,658,500.00
Water Storage System and related Services⁽¹¹⁾⁽¹²⁾⁽¹³⁾⁽¹⁴⁾⁽¹⁵⁾			
500 Gallons	\$5,400.00	772	\$4,168,800.00
[B] Sub-Total Water Storage System			\$4,168,800.00
Total (PV System + Water Storage System): [A]+[B]			\$27,827,300.00

Notes

- 7W
- (8) All equipment to be submitted with the Bid must comply with the specifications included in the Scope of Work.
 - (9) Bidder shall submit technical/specification documentation for all equipment offered as part of the bid.
 - (10) All equipment offered as part of the bid is subject to the Warranty conditions set forth in the Scope of Work.
 - (11) Bids which do not contain pricing for every item requested will be considered unresponsive by the PRDOH.
 - (12) Pricing must include all services associated with the PV System and WSS included in the Scope of Work.
 - (13) Pricing must include all expenses, including incidental, taxes, handling, and delivery costs, as well as any other administrative costs associated with the goods and services. The PRDOH will not consider any additional costs. Only the unit prices submitted will be taken into consideration. The PRDOH will not be responsible for reimbursement of expenses related to per-diem, tolls, parts, or labors for equipment under warranty.
 - (14) Bidders shall provide the pricing for water storage systems inclusive of a 0.5 horsepower (hp) water pump with a pressurized tank and copper tubing/connections.
 - (15) For quotation purposes, the Bidder will quote for the 500-gallon WSS. The PRDOH will determine, during the assessments of applications, which WSS will be installed at each project from those included in Cost Form 1.
 - (16) Maximum quantity of applications included in the Cost Form are the PRDOH's expectation for the current CEWRI allocation of the program at the moment. Therefore, the actual quantities of applications, and therefore units, to be included in the Selected Bidder's contract and that the Selected Proposer might be able to perform will be dependent on the final number of Selected Bidders that might be awarded through the IFB. For Level 1 Contractors, this does not limit the PRDOH in amending the contract of any Selected Bidder to include additional estimated quantities of applications based on performance metrics of the Selected Bidders and according to the Program funds availability. For Level 2 Contractors, PRDOH reserves the right to amend the contracts to include additional applications based on performance metrics up to 485 PV systems and WSS.
- AK

Name of Proposer: Synerlution Energy, LLC (Synerlution, Inc.)

Cost For 3. Allowance

Equipment Description ⁽¹⁷⁾⁽²⁰⁾	Price per Unit
Refrigerator Size (Cubic feet)⁽²¹⁾⁽²²⁾	
18 c/f Refrigerator	N/A
18 c/f w Ice Maker Refrigerator	N/A
21 c/f Refrigerator	N/A
21 c/f w Ice Maker Refrigerator	N/A
Lightbulb Replacement⁽²¹⁾⁽²³⁾	
LED A19 (500 lumen)	N/A
Environmental Review	
Section 106 Environmental Review	N/A
ACM Testing and Report	N/A
LBP Testing and Report	N/A

7W

Notes

- (17) All equipment to be submitted with the Bid to comply with the specifications for such included in the Scope of Work.
- (18) Bidder shall submit technical/specification documentation for all equipment being offered as part of the bid.
- (19) All equipment being offered as part of the bid is subject to the Warranty conditions set forth in the Scope of Work.
- (20) Bids which do not contain pricing for every item requested will be considered unresponsive by the PRDOH.
- (21) Pricing must include all expenses, including incidental, taxes, handling, and delivery costs, as well as any other administrative costs associated with the goods and services. The PRDOH will not consider any additional costs. Only the unit prices submitted will be taken into consideration. The PRDOH will not be responsible for reimbursement of expenses related to per-diem, tolls, parts, or labors for equipment under warranty.
- (22) Refrigerators pricing elements include purchase price, installation cost, and recycling costs of removed refrigerators.
- (23) Prices for bulbs quoted shall be consistent with specifications defined in Attachment 1 (Scope of Work). Bidders shall provide pricing, including costs for installation, and recycling of old bulbs.

W

Bidder's Initials: _____

Name of Proposer: Synerlution Energy, LLC (Synerlution, Inc.)

Cost Type	Total Amount
PV Systems- Acquisition and Installation	\$23,658,500.00
WSS – Acquisition and Installation	\$ 4,168,800.00
Allowance	N/A

TOTAL BID COST \$27,827,300.00

Sum of (a) PV Systems – Acquisition and Installation Cost; plus, (b) WSS – Acquisition and Installation Costs; plus (c) Allowance.

Notes on TOTAL PROPOSAL COST:

1. The TOTAL PROPOSAL COST represents the potential total cost for the equipment and services requested for all the PV Systems, Water Cisterns Acquisition and Installation Services. Allowance costs will be awarded on a case by case basis with approval from PRDOH.
2. The PRDOH aims to contract, at its discretion and in the best interest of the overall programs' implementation, one or more bidders(s).
3. Based on the number of Bidders finally awarded through this IFB, contracts may be signed to manage quantities of systems and/or allowances lower than those considered in this Cost Form.
4. PRDOH will reserve the discretion to amend contracts of awarded Bidders(s) to include additional amounts of systems and/or allowances based on performance metrics.
5. The Allowance of \$3,800,130.00 may be divided among all Selected Bidders in the instance PRDOH determines it's in the best interest of the implementation and administration of the CEWRI Program. Access to Allowance funds requires prior authorization of the PRDOH or its representative, as explained in the Scope of Work.
6. The Bid is to be awarded to the "Responsible Bidder" that submitted the "Responsive Bid" with the lowest cost, taking in consideration the Contractor Levels and Cost Forms. The Contractor Level must not be used as subterfuge to submit a lower Bid Bond.

Bidder's Signature _____

Date _____

Bidder's Printed Name _____



ATTACHMENT E

PERFORMANCE REQUIREMENTS

COMMUNITY ENERGY AND WATER RESILIENCE INSTALLATIONS PROGRAM (CEWRI)

The Installer/Contractor shall provide services in accordance with the Scope of Work of this contract.

Deliverables: The key deliverables to be provided include, but are not limited to, the following:

- Installer/Contractor must submit monthly reports to CEWRI Program Manager and PRDOH. Monthly reports shall be due the fifth (5th) day of each month and shall include:
 - o Copies of all notifications from CEWRI PMs
 - o Inspection orders placed within previous calendar month and inspection reports, as applicable.
 - o Notices to begin the design phase within the previous calendar month
 - o Notices of accepted/rejected designs within previous calendar month
 - o Locations of all pending and completed tasks within the previous calendar month.
 - o Explanation of pending and completed design tasks within the previous calendar month.
 - o Explanation of pending and completed installation tasks within the previous calendar month.
 - o Copies of all payment requests sent to PM within the previous month.
 - o Payment receipt notifications with the date payment was received.
- Installer/Contractor must develop and submit to the PMs the following but not limited to:
 - o Pre-Installation Assessment Visit and Report for each project
 - o Case Scope of work for each project.
 - o System Designs for each Projects
 - o Systems Installation Report
 - o Commissioning Report
 - o All technical documentation, including Components data sheets and listing
 - o Warranties
 - o Installation and operation manuals
 - o As-built version of system drawings, cable lists and routing, wirings, grounding system,
 - o Any other documentation required or requested by PRDOH.

7W

Delivery Schedule

- Coordinate with Applicant and CEWRI Program Manager for any pre-installation assessment visits, installation, and closeout inspections.
- Upon notice from the CEWRI PM firm, the Installer/Contractor shall, **within three (3) working days**, perform the pre-installation assessment and report.
- Upon notice from the CEWRI PM firm, the Installer/Contractor shall, **within six (6) working days**, perform the design of the project and submission of the Interconnection Package to PREPA.
- Upon notice from the CEWRI PM firm, the Installer/Contractor shall, **within seven (7) working days**, install the system(s), perform the commissioning of the project, and submission of the Pre-Inspection Package. If the 7-day period is not enough due to equipment shortage, the Installer/Contractor must provide a written explanation and a copy of the equipment's delivery documents.
- Upon completion of installation, Installer/Contractor shall submit the official payment request to CEWRI PM with all applicable documentation, including warranty. Warranty

ME

documentation shall be submitted in duplicate (one for PM/PRDOH and one for the homeowner/applicant) Installer/Contractor is responsible for delivering warranty information to the homeowner/applicant.

Tasks and Services	DESCRIPTION	TIMEFRAME DATES	DELIVERABLES
Pre-Installation Assessment and Scope of Work	<ul style="list-style-type: none"> - Perform a Pre-Installation Assessment visit to each dwelling units and develop the Pre-Installation Assessment report for each case project. Submit report to the PMs for approval. -Develop case Scope of Work for each project. Submit scope of work to the PMs for approval. 	Upon notice from the CEWRI PM firm, the Installer/Contractor shall, within three (3) working days , perform the pre-installation assessment and report.	For each Application, provide the Pre-Installation Report Form signed and sealed by the licensed professional, and provide any other document required by PRDOH.
Design Services & Permits	The Installer/Contractor must design a standard photovoltaic system with battery back-up and/or Water Storage System for single-family homes.	Upon notice from the CEWRI PM firm, the Installer/Contractor shall, within six (6) working days , perform the design of the project and submission of the Interconnection Package to PREPA.	For each assigned project, the Installer/Contractor must submit System Designs and any applicable permit for each Projects.
Installation Service & Commissioning	<ul style="list-style-type: none"> - For each assigned project, the Installer/Contractor shall install the system(s) and perform the commissioning of the project. - The Installer/Contractor shall perform orientation and training to the Applicants regarding operation and maintenance of the installed systems and equipment. - The Installer/Contractor must deliver all applicable Operation and Maintenance Manuals of the installed systems to each Applicant receiving a system along with any other required documents. 	Upon notice from the CEWRI PM firm, the Installer/Contractor shall, within seven (7) working days , install the system(s), perform the commissioning of the project, and submission of the Pre-Inspection Package. If the 7-day period is not enough due to equipment shortage, the Installer/Contractor must provide a written explanation and a copy of the equipment's delivery documents.	For each assigned project, the Installer/Contractor must submit the Pre-Inspection Package, including but not limited to Systems Installation Report, Commissioning Report, all technical documentation, including components data sheets and listing, warranties, installation and operation & maintenance manuals, as-built version of system drawings, cable lists and routing, wirings, grounding system, and any other document required by PRDOH.
Award Visit	<ul style="list-style-type: none"> -Perform award visit with the PMs to each applicant's property to complete the Project Grant Agreement. -Perform orientation to Applicants of the measures that are being offered and that may be installed in the unit. -Ensure that the applicant is informed on the process, the works to be performed, and the conditions of the award prior to any work being performed. - Assist the PMs during the applicant award process. 	- As per coordination with Applicant and CEWRI Program Manager for award visit.	For each assigned project, the Installer/Contractor must participate and assist in the Award Visit.

rw

JK

<p>Inspections</p>	<p>For each project the Installer/Contractor will visit the project site along with the PRDOH Program Manager and inspect works for overall quality standards.</p>	<p>- As per coordination with Applicant and CEWRI Program Manager for closeout inspections.</p> <p>- Installation corrections, as noted during final acceptance or the post-installation inspection, shall be performed within ten (10) business days. If the Installer/Contractor cannot undertake corrective actions within ten (10) business days, the Installer/Contractor shall deliver to the PM, in writing, reasons for the delay.</p>	<p>For each assigned project, the Installer/Contractor must participate and assist in the Inspection Visit.</p>
<p>Reporting</p>	<p>-Periodic Reporting is required to update the Program's implementation and development status, while providing visibility of the Program's actual status to stakeholders.</p>	<p>-Installer/Contractor must submit monthly reports to CEWRI Program Manager and PRDOH. Monthly reports shall be due the fifth (5th) day of each month</p>	<p>The Installer/Contractor shall submit the following:</p> <ul style="list-style-type: none"> - Copies of all notifications from CEWRI PMs - Inspection orders placed within previous calendar month and inspection reports, as applicable. - Notices to begin the design phase within the previous calendar month - Notices of accepted/rejected designs within previous calendar month - Locations of all pending and completed tasks within the previous calendar month. - Explanation of pending and completed design tasks within the previous calendar month. - Explanation of pending and completed installation tasks within the previous calendar month. - Copies of all payment requests sent to PM within the previous month. - Payment log. - Any other document required by PRDOH.

7/2

The Installer/Contractor shall develop workplans, schedules, reports and/or any other document as may be requested by PRDOH or Representative in connection to the above timelines and performance goals. The Installer/Contractor shall submit any of such documents for review and approval as requested by the PRDOH within the specified time frame provided for such request. PRDOH reserve the rights to request any information as part of the Grantee responsibilities. The Installer/Contractor is also responsible for providing and performing all the services stated in the Scope of Work.

1/1



**OSPA
PV Systems, Water Cisterns Acquisition and Installation Services
Community Development Block Grant – Disaster Recovery
Puerto Rico Department of Housing
Contract Division**

**SPECIAL INSURANCE AND BONDING SPECIFICATIONS
FOR PROFESSIONAL SERVICES**

LICITATION NUMBER - CDBG-DR-IFB-2021-XX

A. All bidders will submit a BID BOND

The bid will be accompanied of a bid bond of five percent (5%) of the amount of the bid and option of the bidder, which will be able to be my means of:

- a. Certified check, or
- b. Bank draft

764
The Bid Bond must be issued by a surety appearing in the latest US Department of Treasury's Listing of Approved Sureties (Circular Letter 570) and authorized to do business in Puerto Rico.

- B.** The successful bidder before commencing work or receiving a written notice to proceed with, or being allowed to start to work, must submit to the ***Puerto Rico Department of Housing (*PRDOH)***, the hereafter mentioned insurance policies and/or bonds, thus including all endorsements and agreements required under the special contractual conditions as per the following:

1. (X) State Insurance Fund Workmen's Compensation Insurance Policy

In accordance with the Workmen's Compensation Act No. 45, to facilitate its acquisition, the ****PRDOH*** shall provide a letter to the successful bidder addressed to the State Insurance Fund.

111

2. (X) Commercial General Liability (Broad Form) including the following insurance coverage

COVERAGE	LIMIT
I. Commercial General Liability:	
• Each Occurrence	\$2,000,000
• General Aggregate	\$2,000,000
• Products & Complete Operations	\$2,000,000
• Personal Injury & Advertising	\$2,000,000
• Fire Damage	\$100,000 (Any one Fire)
• Medical Expense	\$10,000 (Any one person)
II. Employer's Liability Stop Gap:	
• Bodily Injury by Accident Each Employee Each Accident	\$1,000,000 \$1,000,000
• Bodily Injury by Disease Each Employee Each Accident	\$1,000,000 \$1,000,000

7W

3. (X) Comprehensive Automobile Liability Form including the following insurance coverages

LIMIT
<ul style="list-style-type: none"> • Auto Liability - \$1,000,000 • Physical Damages - \$1,000,000 • Medical Payments - \$ 10,000
The Commercial Auto cover must be applied to the following symbols:
<ul style="list-style-type: none"> • Liability Coverage -1 • Physical Damages - 2 and 8 • Hired - Borrowed Auto - 8 • Non-Owned Auto Liability - 9

4. (X) Professional Liability

(X) A. Risk, interest, location and limits

W

(X) A.1 Description of work to be done

(X)A.2Limit:

- (X) each occurrence \$ 1,000,000
- (X) Aggregate \$ 2,000,000
- (X) Deductible \$ 5,000

(X) A.3 Certification that the insurance contract has been given as surplus lines coverage under the Commonwealth Insurance Code, when applicable.

5. (X) Employment Practices Liability

Limit - \$1,000,000

6. (X) Contractor's Pollution Liability

Limit - \$1,000,000

7. (X) Umbrella

Limit - \$10,000,000

8. (X) Builder's Risk – 100% of Finished Value

(x) a. Form for all risks including "DIC" and earthquake.

(x) b. 100% total finished cash value for all finished construction equipment and/or installation equipment provided by the "PRDOH".

(x) c. The "PRDOH" and the Government of Puerto Rico must be included as additional insured.

9. (X) Payment and Performance Bond, Wage Payment Bond, and Labor Materials Payment Bond:

(X) a. A document for the total cost of the project under contract.

(X) b. The surety must be issued by a surety appearing in the latest US Department of Treasury's Listing of Approved Sureties (Circular Letter 570) and authorized to do business in Puerto Rico.

(X) c. You must provide an endorsement on the Performance and Payment Bond to guarantee the payment of wages at the

7W

WU

Department of Labor of the Government of Puerto Rico as an Obligated Guarantor under Laws of Puerto Rico.

(X) d. Certificate of Authority, Power of Attorney and Power of Attorney License issued by the Commissioner of Insurance.

10. The policies to be obtained must contain the following endorsements including as additional insured the ***Puerto Rico Department of Housing (*PRDOH), U.S. Department of Housing and Urban Development (HUD), and the Government of Puerto Rico.***

(X) a. Breach of warranty

(X) b. Waiver and / or Release of Subrogation

(X) c. Additional Insured Clause

(X) d. Hold Harmless Agreement

(X) e. 30 Days Cancellation Clause

70
11. The insurance carrier or carriers, which will present said certificates of insurance must have at least a B+ Rating according to the Best Rating Guide.

C. TERMS AND CONDITIONS

1. All certified checks or bank drafts must be paid to the Order of the Bidding Agency.

2. All Bid Bonds must be issued by an Insurance Company authorized by the Insurance Commissioner of Puerto Rico and must be accompanied by the following documents:

3. Certificate of Authority in the name of the Insurer issued by the Insurance Commissioner.

4. Power of Attorney, issued by the Insurer, in the name of its attorney-in-fact.

5. Power of Attorney License, issued by the Commissioner of Insurance pursuant to the power of attorney issued by said Insurer.

ll
6. If, at the time the bidding, documents are opened, any of the documents referred to in paragraph a, band c above are missing,

this shall not constitute grounds for disqualifying the contractor, but the successful bidder shall submit such documents within two (2) working days from the date and time of the auction.

7. It is implicit that, by issuing the Bid Bond, the insurer undertakes to issue a Performance and Payment Bond in accordance with the conditions of the auction.

8. In any bidding or protest, the interested party shall be obliged to write down each risk with its individual cost of premium and shall then reflect the total sum of all insurance premiums as project costs.

D. IMPORTANT NOTICE TO INSURANCE AND SURETY COMPANIES AND THEIR REPRESENTATIVES

All insurance companies and all guarantors who issue policies or bonds under our special contractual conditions are subject to:

1. Be authorized to do business within the Commonwealth of Puerto Rico and have the corresponding license issued by the Commissioner of Insurance.
2. To be enjoying a good economic situation and to be classified under the Category of B+ Rating according to the "Best Rating Guide".
3. Submit to the ***PRDOH** a written certification as evidence of full payment of premiums by the Contractor. Mention each risk coverage premium separately.
4. Avoid sub-contractual obligations of premium financing or any other kind, which may be detrimental to the public interest.
5. Avoid any request for cancellation by the contractor prior to the expiration date of the policy, without the consent of the Contract Division of the ***PRDOH**: Discuss any refund of unearned premium.
6. Follow all Federal Bail and Acceptance Insurance Regulations, when applicable.

7W

W

7. Indicate in the appropriate place of all insurance policies and/or bonds, the full description of the project, work or service to be rendered.
8. Not to make any amendments to insurance policies and bonds issued under the special conditions mentioned above, unless approved by the Insurance Section of the ***PRDOH**.
9. To ensure that all insurance policies or bonds are issued to comply with all of our special insurance conditions with respect to the period of coverage, type of risk coverage, as well as all limits, as specified, and also to eliminate those exclusions in accordance with our request.
10. Clarify any questions regarding insurance requirements by any means of communication with the Insurance Section of the ***PRDOH** under the Secretary for Legal Affairs.

E. EVIDENCE OF INSURANCE COVERAGE OF EACH SUBCONTRACTOR TO BE SUBMITTED BY THE SUCCESSFUL BIDDER AS THE PRIME CONTRACTOR:

The successful bidder, as the prime contractor, has the duty to require each of the subcontractors or subcontractors to maintain in force all insurance policies and/or bonds necessary to cover their individual participation in the risk or risks related to the subcontracted work or service to be rendered.

Therefore, we emphasize that prior to commencing work or receiving written notice to proceed with such work or being authorized to commence work, the successful prime contractor has the responsibility to provide the ***PRDOH** with evidence to the effect that all insurance and/or bonds required under the special conditions or required under the sub-contract to each of the sub-contractors or sub-sub-contractors are current and duly approved by the Contract Division of the ***PRDOH**.

All insurance policies shall remain in effect for the entire contractual period, so that with any order of change and/or amendment resulting in alteration of the original project completion date or total original cost, the prime contractor shall take the necessary steps to request the insurer to include such changes in all related insurance policies and/or bonds and to submit evidence by appropriate

7W

MM

endorsements with effective dates. Cancellations without consent are not accepted.

The ***PRDOH** reserves the right to stop any work or service under contract until the breach of these requirements has been remedied, so that any delay in the performance of the contract based on any breach of the insurance coverage requirements shall be deemed the sole responsibility of the Main Contractor.

F. CONFLICT OR DIFFERENCE BETWEEN THE SPECIFICATIONS OF THE TENDERING, PROCEDURE AND SPECIAL INSURANCE CONDITIONS AND BONDS, FORM DV-OSPA-78-5

In the event of any conflict or difference in the description of coverage or in amounts or limits, etc., with respect to insurance requirements, the "*Special Conditions of Insurance and Bonds*" as set forth in this **Form (DV-OSPA-78-5)** shall prevail over any other insurance specifications.

7W

G. CERTIFICATE OF CONTRACT DIVISION

We hereby certify, to our best knowledge and understanding, that we have prepared the aforementioned "*Insurance and Bonds Special Conditions*" after a proper evaluation of the related risks, based on the information of the nature of the project and description submitted to us, as requested by the Contracting Program through a written application.

DESCRIPTION OF THE SERVICES:

PV Systems, Water Cisterns Acquisition and Installation Services

W

April 9, 2021
Date

Candice M. Noriega Morales
Candice M. Noriega Morales
Insurance Specialist
CDBG-DR Program

ATTACHMENT G

CDBG-DR Program
HUD General Provisions
Page 1 / 18

HUD GENERAL PROVISIONS

Given that the Contract involves funds for which the U.S. Department of Housing and Urban Development (**HUD**) is the oversight agency, the following terms and conditions may apply to this Contract. In addition, Contractor shall comply with the Federal Labor Standards Provisions set forth in Form HUD-4010, available at <https://www.hudexchange.info/resource/2490/hud-form-4010-federal-labor-standards-provisions/>

The CONTRACTOR shall include these terms and conditions in all subcontracts or purchase orders directly servicing the Contract.

These general provisions may be updated from time to time. It is the sole responsibility of the CONTRACTOR to be aware of any changes hereto, to amend and implement such changes and to ensure subcontracts terms and conditions are modified as necessary, if any.

General Provisions:

7W

1. PROVISIONS REQUIRED BY LAW DEEMED INSERTED

Each and every provision of law and clause required by law to be inserted in this Contract shall be deemed to be inserted herein and the Contract shall be read and enforced as though it were included herein, and if through mistake or otherwise any such provision is not inserted, or is not correctly inserted, then upon the application of either party, the Contract shall forthwith be physically amended to make such insertion or correction.

2. STATUTORY AND REGULATORY COMPLIANCE

CONTRACTOR shall comply with all laws and regulations applicable to the Community Development Block Grant-Disaster Recovery funds appropriated by: the Continuing Appropriations Act, 2018, and Supplemental Appropriations for Disaster Relief Requirements, 2017 (**Pub. L. 115-56**) approved on September 8, 2017, as amended; the Bipartisan Budget Act of 2018 (**Pub. L. 115-123**) approved on February 9, 2018, as amended; the Additional Supplemental Appropriations for Disaster Relief Act, 2019, (**Pub. L. 116-20**) approved on June 6, 2019, as amended; as well as including, but not limited to the applicable Office of Management and Budget Circulars, which may impact the administration of funds and/or set forth certain cost principles, including if certain expenses are allowed.

UU

3. BREACH OF CONTRACT TERMS

The Puerto Rico Department of Housing (**PRDOH**) reserves its right to all administrative, contractual, or legal remedies, including but not limited to suspension or termination of

this Contract, in instances where the CONTRACTOR or any of its subcontractors violate or breach any Contract term. If the CONTRACTOR or any of its subcontractors violate or breach any Contract term, they shall be subject to such sanctions and penalties as may be appropriate. The duties and obligations imposed by the Contract documents, and the rights and remedies available thereunder shall be in addition to and not a limitation of any duties, obligations, rights and remedies otherwise imposed or available by law.

4. REPORTING REQUIREMENTS

The CONTRACTOR shall complete and submit all reports, in such form and according to such schedule, as may be required by PRDOH and/or the Government of Puerto Rico. The CONTRACTOR shall cooperate with all the PRDOH and/or the Government of Puerto Rico efforts to comply with HUD requirements and regulations pertaining to reporting, including but not limited to 24 C.F.R. §§ 85.40-41 (or 84.50-52, if applicable) and § 570.507, when applicable.

5. ACCESS TO RECORDS

7W The Government of Puerto Rico, the PRDOH, HUD, the Comptroller General of the United States, or any of their duly authorized representatives, shall have, at any time and from time to time during normal business hours, access to any work product, books, documents, papers, and records of the CONTRACTOR which are related to this Contract, for the purpose of inspection, audits, examinations, and making excerpts, copies and transcriptions.

6. MAINTENANCE/RETENTION OF RECORDS

All records (files, data, work product) connected with this Contract will be turned over to PRDOH following the Agreement termination to be maintained for the remainder of the grant and post grant closeout.

7. SMALL AND MINORITY FIRMS, WOMEN'S BUSINESS ENTERPRISES, AND LABOR SURPLUS AREA FIRMS

The CONTRACTOR will take necessary affirmative steps to assure that minority firms, women's business enterprises, and labor surplus area firms are used in subcontracting when possible. Steps include, but are not limited to:

- WU
- (i) Placing qualified small and minority businesses and women's business enterprises on solicitation lists;
 - (ii) Assuring that small and minority businesses, and women's business enterprises are solicited whenever they are potential sources;

- (iii) Dividing total requirements, when economically feasible, into smaller tasks or quantities to permit maximum participation by small and minority business, and women's business enterprises;
- (iv) Establishing delivery schedules, where the requirement permits, which encourage participation by small and minority business, and women's business enterprises; and
- (v) Using the services and assistance of the Small Business Administration, and the Minority Business Development Agency of the Department of Commerce.

Additionally, for contracts of **\$10,000 or more**, the CONTRACTOR shall file Form HUD 2516 (Contract and Subcontract Activity) with the PRDOH on a quarterly basis.

8. RIGHTS TO INVENTIONS MADE UNDER A CONTRACT OR AGREEMENT

7W
Contracts or agreements for the performance of experimental, developmental, or research work shall provide for the rights of the Federal Government and the recipient in any resulting invention in accordance with 37 C.F.R. Part 401, "Rights to Inventions Made by Nonprofit Organizations and Small Business Firms Under Government Grants, Contracts and Cooperative Agreements", and any implementing regulations issued by HUD.

9. TITLE VI OF THE CIVIL RIGHTS ACT OF 1964

The Proposer will comply with the provisions of Title VI of the Civil Rights Act of 1964, which prohibits discrimination on the basis of race, color, or national origin in any program or activity that receives Federal funds or other Federal financial assistance. Programs that receive Federal funds cannot distinguish among individuals on the basis of race, color or national origin, either directly or indirectly, in the types, quantity, quality or timelines of program services, aids or benefits that they provide or the manner in which they provide them. This prohibition applies to intentional discrimination as well as to procedures, criteria or methods of administration that appear neutral but have a discriminatory effect on individuals because of their race, color, or national origin. Policies and practices that have such an effect must be eliminated unless a recipient can show that they were necessary to achieve a legitimate nondiscriminatory objective.

10. SECTION 109 OF THE HOUSING AND COMMUNITY DEVELOPMENT ACT OF 1974

W
The CONTRACTOR shall comply with the provisions of Section 109 of the Housing and Community Development Act of 1974. No person in the United States shall on the grounds of race, color, national origin, religion or sex be excluded from participation in, be denied the benefits of, or be subjected to discrimination under any program or activity funded in whole or in part with funds made available under this title. Section 109 further provides that discrimination on the basis of age under the Age Discrimination Act of 1975 or with

respect to an otherwise qualified handicapped individual as provided in Section 504 of the Rehabilitation Act of 1973, as amended, is prohibited.

11. SECTION 504 OF THE REHABILITATION ACT OF 1973

The CONTRACTOR shall comply with Section 504 of the Rehabilitation Act of 1973 (29 U.S.C. § 794), as amended, and any applicable regulations.

The CONTRACTOR agrees that no qualified individual with handicaps shall, solely on the basis of handicap, be excluded from participation in, be denied the benefits of, or otherwise be subjected to discrimination under any program or activity that receives Federal financial assistance from HUD.

12. AGE DISCRIMINATION ACT OF 1975

76
The CONTRACTOR shall comply with the Age Discrimination Act of 1975 (42 U.S.C. § 6101 *et seq.*), as amended, and any applicable regulations. No person in the United States shall, on the basis of age, be excluded from participation in, be denied the benefits of, or be subjected to, discrimination under, any program or activity receiving Federal financial assistance.

13. DEBARMENT, SUSPENSION, AND INELIGIBILITY

The CONTRACTOR represents and warrants that it and its subcontractors are not debarred or suspended or otherwise excluded from or ineligible for participation in Federal assistance programs subject to 2 C.F.R. Part 2424.

14. CONFLICTS OF INTEREST

The CONTRACTOR shall notify the PRDOH as soon as possible if this Contract or any aspect related to the anticipated work under this Contract raises an actual or potential conflict of interest (as defined at 2 C.F.R. Part 215 and 24 C.F.R. § 85.36 or 84.42, if applicable). The CONTRACTOR shall explain the actual or potential conflict in writing in sufficient detail so that the PRDOH is able to assess such actual or potential conflict. The CONTRACTOR shall provide the PRDOH any additional information necessary to fully assess and address such actual or potential conflict of interest. The CONTRACTOR shall accept any reasonable conflict mitigation strategy employed by the PRDOH, including but not limited to the use of an independent subcontractor(s) to perform the portion of work that gives rise to the actual or potential conflict.

111
15. SUBCONTRACTING

When subcontracting, the CONTRACTOR shall solicit for and contract with such subcontractors in a manner providing for fair competition. Some of the situations considered to be restrictive of competition include, but are not limited to:

- (i) Placing unreasonable requirements on firms in order for them to qualify to do business;
- (ii) Requiring unnecessary experience and excessive bonding;
- (iii) Noncompetitive pricing practices between firms or between affiliated Companies;
- (iv) Noncompetitive awards to consultants that are on retainer contracts,
- (v) Organizational conflicts of interest;
- (vi) Specifying only a brand name product instead of allowing an equal product to be offered and describing the performance of other relevant requirements of the procurement; and
- (vii) Any arbitrary action in the procurement process.

The CONTRACTOR represents to the PRDOH that all work shall be performed by personnel experienced in the appropriate and applicable profession and areas of expertise, taking into account the nature of the work to be performed under this Contract.

The CONTRACTOR will include these HUD General Provisions in every subcontract issued by it, so that such provisions will be binding upon each of its subcontractors as well as the requirement to flow down such terms to all lower-tiered subcontractors.

7W

16. ASSIGNABILITY

The CONTRACTOR shall not assign any interest in this Agreement, and shall not transfer any interest in the same (whether by assignment or novation) without prior written approval of the PRDOH.

17. INDEMNIFICATION

The CONTRACTOR shall indemnify, defend, and hold harmless the Government of Puerto Rico and PRDOH, its agents and employees, from and against any and all claims, actions, suits, charges, and judgments arising from or related to the negligence or willful misconduct of the CONTRACTOR in the performance of the services called for in this Contract.

18. COPELAND "ANTI-KICKBACK" ACT

(Applicable to all construction or repair contracts)

UN

Salaries of personnel performing work under this Contract shall be paid unconditionally and not less often than once a month without payroll deduction or rebate on any account except only such payroll deductions as are mandatory by law or permitted by the applicable regulations issued by the Secretary of Labor pursuant to the Copeland "Anti-Kickback Act" of June 13, 1934 (48 Stat. 948; 62 Stat. 740; 63 Stat. 108; Title 18 U.S.C. § 874; and Title 40 U.S.C. § 276c). The CONTRACTOR shall comply with all applicable "Anti-Kickback" regulations and shall insert appropriate provisions in all subcontracts covering

work under this Agreement to ensure compliance by subcontractors with such regulations, and shall be responsible for the submission of affidavits required of subcontractors thereunder except as the Secretary of Labor may specifically provide for variations of or exemptions from the requirements thereof.

19. CONTRACT WORK HOURS AND SAFETY STANDARDS ACT

(Applicable to construction contracts exceeding \$2,000 and contracts exceeding \$2,500 that involve the employment of mechanics or laborers.)

The CONTRACTOR shall comply with Sections 103 and 107 of the Contract Work Hours and Safety Standards Act (40 U.S.C. §§ 3701-3708) as supplemented by Department of Labor regulations (29 C.F.R. Part 5).

All laborers and mechanics employed by CONTRACTORS or subcontractors shall receive overtime compensation in accordance with and subject to the provisions of the Contract Work Hours and Safety Standards Act, and the CONTRACTORS and subcontractors shall comply with all regulations issued pursuant to that act and with other applicable Federal laws and regulations pertaining to labor standards.

700
20. DAVIS-BACON ACT

(Applicable to construction contracts exceeding \$2,000 when required by Federal program legislation.)

The CONTRACTOR shall comply with the Davis Bacon Act (40 U.S.C. §§ 3141, *et seq.*) as supplemented by Department of Labor regulations (29 C.F.R. Part 5).

All laborers and mechanics employed by CONTRACTORS or subcontractors, including employees of other governments, on construction work assisted under this Contract, and subject to the provisions of the federal acts and regulations listed in this paragraph, shall be paid wages at rates not less than those prevailing on similar construction in the locality as determined by the Secretary of Labor in accordance with the Davis-Bacon Act.

On a semi-annual basis, the CONTRACTOR shall submit Form HUD 4710 (Semi-Annual labor Standards Enforcement Report) to PRDOH.

AM
21. TERMINATION FOR CAUSE

(Applicable to contracts exceeding \$10,000)

If, through any cause, the CONTRACTOR shall fail to fulfill in a timely and proper manner his or her obligations under this Contract, or if the CONTRACTOR shall violate any of the covenants, agreements, or stipulations of this Contract, the PRDOH shall thereupon have the right to terminate this Contract by giving written notice to the CONTRACTOR of such termination and specifying the effective date thereof, at least five (5) days before the

effective date of such termination. In such event, all finished or unfinished documents, data, studies, surveys, drawings, maps, models, photographs, and reports prepared by the CONTRACTOR under this Agreement shall, at the option of the PRDOH, become the PRDOH's property and the CONTRACTOR shall be entitled to receive just and equitable compensation for any work satisfactorily completed hereunder. Notwithstanding the above, the CONTRACTOR shall not be relieved of liability to the Government of Puerto Rico and PRDOH for damages sustained by the Government of Puerto Rico and/or PRDOH by virtue of any breach of the Agreement by the CONTRACTOR, and the Government of Puerto Rico and/or PRDOH may withhold any payments to the CONTRACTOR for the purpose of set-off until such time as the exact amount of damages due to the Government of Puerto Rico and/or PRDOH from the CONTRACTOR is determined.

22. TERMINATION FOR CONVENIENCE
(Applicable to contracts exceeding \$10,000)

7W
The PRDOH may terminate this Contract at any time by giving at least ten (10) days' notice in writing to the CONTRACTOR. If the Contract is terminated by the PRDOH as provided herein, the CONTRACTOR will be paid for the time provided and expenses incurred up to the termination date.

23. SECTION 503 OF THE REHABILITATION ACT OF 1973
(Applicable to contracts exceeding \$10,000)

The CONTRACTOR shall comply with Section 503 of the Rehabilitation Act of 1973 (29 U.S.C. § 793), as amended, and any applicable regulations.

Equal Opportunity for Workers with Disabilities:

1) The CONTRACTOR will not discriminate against any employee or applicant for employment because of physical or mental disability in regard to any position for which the employee or applicant for employment is qualified. The CONTRACTOR agrees to take affirmative action to employ, advance in employment and otherwise treat qualified individuals with disabilities without discrimination based on their physical or mental disability in all employment practices, including the following:

- 8W
- (i) Recruitment, advertising, and job application procedures;
 - (ii) Hiring, upgrading, promotion, award of tenure, demotion, transfer, layoff, termination, right of return from layoff and rehiring;
 - (iii) Rates of pay or any other form of compensation and changes in compensation;

- (iv) Job assignments, job classifications, organizational structures, position descriptions, lines of progression, and seniority lists;
 - (v) Leaves of absence, sick leave, or any other leave;
 - (vi) Fringe benefits available by virtue of employment, whether or not administered by the CONTRACTOR;
 - (vii) Selection and financial support for training, including apprenticeship, professional meetings, conferences, and other related activities, and selection for leaves of absence to pursue training;
 - (viii) Activities sponsored by the CONTRACTOR including social or recreational programs; and
 - (ix) Any other term, condition, or privilege of employment.
- 2) The CONTRACTOR agrees to comply with the rules, regulations, and relevant orders of the Secretary of Labor issued pursuant to the act.
- 3) In the event of the CONTRACTOR's noncompliance with the requirements of this clause, actions for noncompliance may be taken in accordance with the rules, regulations, and relevant orders of the Secretary of Labor issued pursuant to the act.
- 700
- 4) The CONTRACTOR agrees to post in conspicuous places, available to employees and applicants for employment, notices in a form to be prescribed by the Deputy Assistant Secretary for Federal Contract Compliance Programs, provided by or through the contracting officer. Such notices shall state the rights of applicants and employees as well as the CONTRACTOR'S obligation under the law to take affirmative action to employ and advance in employment qualified employees and applicants with disabilities. The CONTRACTOR must ensure that applicants and employees with disabilities are informed of the contents of the notice (e.g., the CONTRACTOR may have the notice read to a visually disabled individual, or may lower the posted notice so that it might be read by a person in a wheelchair).
- 5) The CONTRACTOR will notify each labor organization or representative of workers with which it has a collective bargaining agreement or other contract understanding, that the CONTRACTOR is bound by the terms of Section 503 of the Rehabilitation Act of 1973, as amended, and is committed to take affirmative action to employ and advance in employment individuals with physical or mental disabilities.
- 6) The CONTRACTOR will include the provisions of this clause in every subcontract or purchase order in excess of \$10,000, unless exempted by the rules, regulations, or orders of the Secretary issued pursuant to Section 503 of the act, as amended, so that such provisions will be binding upon each subcontractor or vendor. The
- MA

CONTRACTOR will take such action with respect to any subcontract or purchase order as the Deputy Assistant Secretary for Federal Contract Compliance Programs may direct to enforce such provisions, including action for noncompliance.

24. EQUAL EMPLOYMENT OPPORTUNITY

(Applicable to construction contracts and subcontracts exceeding \$10,000)

The CONTRACTOR shall comply with Executive Order 11246 of September 24, 1965, entitled "Equal Employment Opportunity," as amended by Executive Order 11375 of October 13, 1967, and as supplemented in Department of Labor regulations (41 C.F.R. chapter 60).

During the performance of this Agreement, the CONTRACTOR agrees as follows:

- 1) The CONTRACTOR shall not discriminate against any employee or applicant for employment because of race, color, religion, sex, or national origin. The CONTRACTOR shall take affirmative action to ensure that applicants for employment are employed, and that employees are treated during employment, without regard to their race, color, religion, sex, or national origin. Such action shall include, but not be limited to, the following: employment, upgrading, demotion, or transfer; recruitment or recruitment advertising; layoff or termination; rates of pay or other forms of compensation; and selection for training, including apprenticeship.
- 2) The CONTRACTOR shall post in conspicuous places, available to employees and applicants for employment, notices to be provided by Contracting Officer setting forth the provisions of this non-discrimination clause. The CONTRACTOR shall state that all qualified applicants will receive consideration for employment without regard to race, color, religion, sex, or national origin.
- 3) The CONTRACTOR will, in all solicitations or advertisements for employees placed by or on behalf of the CONTRACTOR, state that all qualified applicants will receive consideration for employment without regard to race, color, religion, sex or national origin.
- 4) The CONTRACTOR will send to each labor union or representative of workers with which he or she has a collective bargaining agreement or other contract or understanding, a notice, to be provided by the agency contracting officer, advising the labor union or workers representative of the CONTRACTOR's commitments under Section 202 of Executive Order 11246 of September 24, 1965, and shall post copies of the notice in conspicuous places available to employees and applicants for employment.

7W

W

- 5) The CONTRACTOR will comply with all provisions of Executive Order 11246 of September 24, 1965, and of the rules, regulations and relevant orders of the Secretary of Labor.
- 6) The CONTRACTOR will furnish all information and reports required by Executive Order 11246 of September 24, 1965, and by the rules, regulations and orders of the Secretary of Labor, or pursuant thereto, and will permit access to books, records and accounts by the contracting agency and the Secretary of Labor for purposes of investigation to ascertain compliance with such rules, regulations and orders.
- 7) In the event of the CONTRACTOR's non-compliance with the non-discrimination clause of this Agreement or with any of such rules, regulations or orders, this Agreement may be cancelled, terminated or suspended in whole or in part and the CONTRACTOR may be declared ineligible for further government contracts in accordance with procedures authorized in Executive Order 11246 and such other sanctions as may be imposed and remedies invoked as provided in Executive Order 11246 of September 24, 1965, or by rule, regulation or order of the Secretary of Labor, or as otherwise provided by law.
- 8) CONTRACTOR shall incorporate the provisions of 1 through 7 above in every subcontract or purchase order unless exempted by rules, regulations or orders of the Secretary of Labor so that such provisions shall be binding on such subcontractor. The CONTRACTOR will take such action with respect to any subcontract or purchase order as the contracting agency may direct as a means of enforcing such provisions including sanctions for non-compliance, provided, however, that in the event the CONTRACTOR becomes involved in, or is threatened with, litigation with a subcontractor or vendor as a result of such direction by the contracting agency, the CONTRACTOR may request the United States to enter into such litigation to protect the interests of the United States.

25. CERTIFICATION OF NONSEGREGATED FACILITIES
(Applicable to construction contracts exceeding \$10,000)

The CONTRACTOR certifies that it does not maintain or provide for its establishments, and that it does not permit employees to perform their services at any location, under its control, where segregated facilities are maintained. It certifies further that it will not maintain or provide for employees any segregated facilities at any of its establishments, and it will not permit employees to perform their services at any location under its control

where segregated facilities are maintained. The CONTRACTOR agrees that a breach of this certification is a violation of the equal opportunity clause of this Agreement.

As used in this certification, the term "segregated facilities" means any waiting rooms, work areas, rest rooms and wash rooms, restaurants and other eating areas, time clocks, locker rooms, and other storage or dressing areas, parking lots, drinking fountains, recreation or entertainment areas, transportation and housing facilities provided for employees which are segregated by explicit directive or are, in fact, segregated on the basis of race, color, religion, or national origin because of habit, local custom, or any other reason.

The CONTRACTOR further agrees that (except where it has obtained for specific time periods) it will obtain identical certification from proposed subcontractors prior to the award of subcontracts exceeding \$10,000 which are not exempt from the provisions of the equal opportunity clause; that it will retain such certifications in its files; and that it will forward the preceding notice to such proposed subcontractors (except where proposed subcontractors have submitted identical certifications for specific time periods).

7W

**26. CERTIFICATION OF COMPLIANCE WITH CLEAN AIR AND WATER ACTS
(Applicable to contracts exceeding \$100,000)**

The CONTRACTOR and all subcontractors shall comply with the requirements of the Clean Air Act, as amended, 42 U.S.C. § 7401 *et seq.*, the Federal Water Pollution Control Act, as amended, 33 U.S.C. § 1251 *et seq.*, and the regulations of the Environmental Protection Agency with respect thereto, at 40 C.F.R. Part 15 and 32, as amended, Section 508 of the Clean Water Act (33 U.S.C. § 1368) and Executive Order 11738.

In addition to the foregoing requirements, all nonexempt contractors and subcontractors shall furnish to the owner, the following:

- 1) A stipulation by the CONTRACTOR or subcontractors, that any facility to be utilized in the performance of any nonexempt contract or subcontract, is not listed on the Excluded Party Listing System pursuant to 40 C.F.R. Part 32 or on the List of Violating Facilities issued by the Environmental Protection Agency (**EPA**) pursuant to 40 C.F.R. Part 15, as amended.
 - 2) Agreement by the CONTRACTOR to comply with all the requirements of Section 114 of the Clean Air Act, as amended, (42 U.S.C. § 7414) and Section 308 of the Federal Water Pollution Control Act, as amended, (33 U.S.C. § 1318) relating to inspection, monitoring, entry, reports and information, as well as all other requirements specified
- AK

in said Section 114 and Section 308, and all regulations and guidelines issued thereunder.

- 3) A stipulation that as a condition for the award of the Agreement, prompt notice will be given of any notification received from the Director, Office of Federal Activities, EPA, indicating that a facility utilized, or to be utilized for the Agreement, is under consideration to be listed on the Excluded Party Listing System or the EPA List of Violating Facilities.
- 4) Agreement by the CONTRACTOR that he or she will include, or cause to be included, the criteria and requirements in paragraph (1) through (4) of this section in every nonexempt subcontract and requiring that the CONTRACTOR will take such action as the government may direct as a means of enforcing such provisions.

27. ANTI-LOBBYING

(Applicable to contracts exceeding \$100,000)

By the execution of this Contract, the CONTRACTOR certifies, to the best of his or her knowledge and belief, that:

- 7W
- 1) No Federal appropriated funds have been paid or will be paid, by or on behalf of the CONTRACTOR, to any person for influencing or attempting to influence an officer or employee of an agency, a Member of Congress, an officer or employee of Congress, or an employee of a Member of Congress in connection with the awarding of any Federal contract, the making of any Federal grant, the making of any Federal loan, the entering into of any cooperative agreement, and the extension, continuation, renewal, amendment, or modification of any Federal contract, grant, loan, or cooperative agreement.
 - 2) If any funds other than Federal appropriated funds have been paid or will be paid to any person for influencing or attempting to influence an officer or employee of any agency, a Member of Congress, an officer or employee of Congress, or an employee of a Member of Congress in connection with this Federal contract, grant, loan, or cooperative agreement, the CONTRACTOR shall complete and submit Standard Form-LLL, "Disclosure of Lobbying Activities", in accordance with its instructions.
 - 3) The CONTRACTOR shall require that the language of this certification be included in the award documents for all subawards at all tiers (including subcontracts, subgrants, and contracts under grants, loans, and cooperative agreements) and that all subrecipients shall certify and disclose accordingly.
- JK

This certification is a material representation of fact upon which reliance was placed when this transaction was made or entered into. Submission of this certification is a prerequisite for making or entering into this transaction imposed by Section 1352, Title 31, U.S. Code. Any person who fails to file the required certification shall be subject to a civil penalty of not less than \$10,000 and not more than \$100,000 for each such failure.

28. BONDING REQUIREMENTS

(Applicable to construction and facility improvement contracts exceeding \$100,000)

The CONTRACTOR shall comply with Puerto Rico bonding requirements, unless they have not been approved by HUD, in which case the CONTRACTOR shall comply with the following minimum bonding requirements:

- 7W
- 1) A bid guarantee from each bidder equivalent to five percent (5%) of the bid price. The "bid guarantee" shall consist of a firm commitment such as a bid bond, certified check, or other negotiable instrument accompanying a bid as assurance that the bidder will, upon acceptance of his or her bid, execute such contractual documents as may be required within the time specified.
 - 2) A performance bond on the part of the CONTRACTOR for one hundred percent (100%) of the Agreement price. A "performance bond" is one executed in connection with a contract to secure fulfillment of all the CONTRACTOR's obligations under such contract.
 - 3) A payment bond on the part of the CONTRACTOR for one hundred percent (100%) of the Agreement price. A "payment bond" is one executed in connection with a contract to assure payment as required by law of all persons supplying labor and material in the execution of the work provided for in the contract.

29. SECTION 3 OF THE HOUSING AND URBAN DEVELOPMENT ACT OF 1968

(As required by applicable thresholds)

- W
- 1) The work to be performed under this Agreement is subject to the requirements of Section 3 of the Housing and Urban Development Act of 1968, as amended, 12 U.S.C. § 1701u (**Section 3**). The purpose of Section 3 is to ensure that employment and other economic opportunities generated by HUD assistance or HUD-assisted projects covered by Section 3, shall, to the greatest extent feasible, be directed to low- and very low-income persons, particularly persons who are recipients of HUD assistance for housing.

- 2) The parties to this Agreement agree to comply with HUD's regulations in 24 C.F.R. Part 75 which implement Section 3. As evidenced by their execution of this Agreement, the parties to this Agreement certify that they are under no contractual or other impediment that would prevent them from complying with the Part 75 regulations.
- 3) The CONTRACTOR agrees to send to each labor organization or representative of workers with which the CONTRACTOR has a collective bargaining agreement or other understanding, if any, a notice advising the labor organization or workers' representative of the CONTRACTOR's commitments under this Section 3 clause, and will post copies of the notice in conspicuous places at the work site where both employees and applicants for training and employment positions can see the notice. The notice shall describe the Section 3 preference, shall set forth minimum number and job titles subject to hire, availability of apprenticeship and training positions, the qualifications for each; and the name and location of the person(s) taking applications for each of the positions; and the anticipated date the work shall begin.
- 7W 4) The CONTRACTOR agrees to include this Section 3 clause in every subcontract subject to compliance with regulations in 24 C.F.R. Part 75, and agrees to take appropriate action, as provided in an applicable provision of the subcontract or in this Section 3 clause, upon a finding that the subcontractor is in violation of the regulations in 24 C.F.R. Part 75. The CONTRACTOR will not subcontract with any subcontractor where the CONTRACTOR has notice or knowledge that the subcontractor has been found in violation of the regulations in 24 C.F.R. Part 75.
- 5) The CONTRACTOR will certify that any vacant employment positions, including training positions, that are filled: (1) after the CONTRACTOR is selected but before the contract is executed, and (2) with persons other than those to whom the regulations of 24 C.F.R. Part 75 require employment opportunities to be directed, were not filled to circumvent the CONTRACTOR's obligations under 24 C.F.R. Part 75.
- 6) Noncompliance with HUD's regulations in 24 C.F.R. Part 75 may result in sanctions, termination of this Agreement for default, and debarment or suspension from future HUD assisted contracts.
- 7) With respect to work performed in connection with Section 3 covered Indian housing assistance, Section 7(b) of the Indian Self-Determination and Education Assistance Act (46 U.S.C. § 5307) also applies to the work to be performed under this Agreement. Section 7(b) requires that to the greatest extent feasible: (i) preference and opportunities for training and employment shall be given to Indians, and (ii) preference in the award of contracts and subcontracts shall be given to Indian



organizations and Indian-owned Economic Enterprises. Parties to this Agreement that are subject to the provisions of Section 3 and Section 7(b) agree to comply with Section 3 to the maximum extent feasible, but not in derogation of compliance with Section 7(b).

- 8) For contracts exceeding \$100,000, the CONTRACTOR shall submit Form HUD 60002 (Section 3 Summary Report) to PRDOH on a quarterly basis, notwithstanding the annual reporting requirement set forth in that form's instructions.

30. FAIR HOUSING ACT

CONTRACTOR shall comply with the provisions of the Fair Housing Act of 1968, as amended. The act prohibits discrimination in the sale or rental of housing, the financing of housing or the provision of brokerage services against any person on the basis of race, color, religion, sex, national origin, handicap or familial status. The Equal Opportunity in Housing Act prohibits discrimination against individuals on the basis of race, color, religion, sex or national origin in the sale, rental, leasing or other disposition of residential property, or in the use or occupancy of housing assisted with Federal funds.

31. ENERGY POLICY AND CONSERVATION ACT

CONTRACTOR shall comply with mandatory standards and policies relating to energy efficiency as contained in the Government of Puerto Rico's energy conservation plan, issued in compliance with the Energy Policy and Conservation Act (42 U.S.C. 6201 et seq).

32. HATCH ACT

CONTRACTOR agrees to comply with mandatory standards and policies relating to Hatch Act, Public Law 76-252, as amended.

The Hatch Act applies to political activities of certain state and local employees. As a Puerto Rico Department of Housing CONTRACTOR, you may do any of the following activities: be a candidate in nonpartisan elections; attend political meetings and conventions; contribute money; campaign in partisan elections; and hold office in political parties.

The CONTRACTOR may not do the following activities: be a candidate in partisan elections; use official influence to interfere in elections; coerce political contributions from subordinates in support of political parties or candidates. The office of special counsel operates a website that provides guidance concerning hatch act issues.

33. HEALTH AND SAFETY STANDARDS

All parties participating in this project agree to comply with Sections 107 and 103 of the Contract Work Hours and Safety Standards Act. Section 107 of the Act is applicable to construction work and provides that no laborer or mechanic shall be required to work in surroundings or under working conditions, which are unsanitary, hazardous, or dangerous to his or her health and safety as determined under construction, safety, and health standards promulgated by the Secretary of Labor. These requirements do not apply to the purchase of supplies or materials or articles ordinarily available on the open market, or contracts for transportation.

34. PERSONNEL

7W
The CONTRACTOR represents that it has, or will secure at its own expense, all personnel required in performing the services under this Agreement. Such personnel shall not be employees of, or have any contractual relationship with, the contracting party. All the services required hereunder will be performed by the CONTRACTOR or under its supervision, and all personnel engaged in the work shall be fully qualified and shall be authorized or permitted under State and local law to perform such services. No person who is serving sentence in a penal or correctional institution shall be employed on work under this Contract.

35. WITHHOLDING OF WAGES

If in the performance of this Agreement, there is any underpayment of wages by the CONTRACTOR or by any subcontractor thereunder, the PRDOH may withhold from the CONTRACTOR out of payment due to him or her an amount sufficient to pay to employees underpaid the difference between the wages required thereby to be paid and the wages actually paid such employees for the total number of hours worked. The amounts withheld may be disbursed by the PRDOH for and on account of the CONTRACTOR or subcontractor to the respective employees to whom they are due.

36. CLAIMS AND DISPUTES PERTAINING TO WAGE RATES

Claims and disputes pertaining to wage rates or to classifications of professional staff or technicians performing work under this Contract shall be promptly reported in writing by the CONTRACTOR to the PRDOH for the latter's decision, which shall be final with respect thereto.

37. DISCRIMINATION BECAUSE OF CERTAIN LABOR MATTERS

W
No person employed on the services covered by this Agreement shall be discharged or in any way discriminated against because he or she has filed any complaint or instituted or caused to be instituted any proceeding or has testified or is about to testify in any proceeding under or relating to the labor standards applicable hereunder to his or her employer.

38. INTEREST OF MEMBERS OF LOCAL PUBLIC AGENCY AND OTHERS

The CONTRACTOR agrees to establish safeguards to prohibit employees from using positions for a purpose that is or gives the appearance of being motivated by a desire for private gain for themselves or others, particularly those with whom they have a family, business, or other tie. The CONTRACTOR will be aware of and avoid any violation of the laws of this State which prohibit municipal officers and employees from having or owning any interest or share, individually or as agent or employee of any person or corporation, either directly or indirectly, in any contract made or let by the governing authorities of such municipality for the construction or doing of any public work, or for the sale or purchase of any materials, supplies or property of any description, or for any other purpose whatsoever, or in any subcontract arising therefrom or connected therewith, or to receive, either directly or indirectly, any portion or share of any money or other thing paid for the construction or doing of any public work, or for the sale or purchase of any property, or upon any other contract made by the governing authorities of the municipality, or subcontract arising therefore or connected therewith.

7W
The CONTRACTOR will also be aware of and avoid any violation of the laws of this State which prescribe a criminal penalty for any public officer who has an interest in any contract passed by the board of which he or she is a member during the time he or she was a member and for one year thereafter.

39. INTEREST OF CERTAIN FEDERAL OFFICERS

No member of, or delegate to, the Congress of the United States and no Resident Commissioner shall be admitted any share or part of this Agreement or to any benefit to arise therefrom.

40. INTEREST OF CONTRACTOR

The CONTRACTOR agrees that it presently has no interest and shall not acquire any interest, direct or indirect, in the above described project or any parcels therein or any other interest which would conflict in any manner or degree with the performance of the Work hereunder. The CONTRACTOR further agrees that no person having any such interest shall be employed in the performance of this Agreement.

41. POLITICAL ACTIVITY

WM
The CONTRACTOR will comply with the provisions of the Hatch Act (5 U.S.C. § 1501 et seq.), which limits the political activity of employees.

42. RELIGIOUS ACTIVITY

The CONTRACTOR agrees to abstain from using any funds related to this Agreement for inherently religious activities prohibited by 24 C.F.R. § 570.200(j), such as worship, religious instruction, or proselytization.

43. FLOOD DISASTER PROTECTION ACT OF 1973

The CONTRACTOR will ensure that procedures and mechanisms are put into place to monitor compliance with all flood insurance requirements as found in the Flood Disaster Protection Act of 1973, 24 C.F.R. § 570.605.

44. LEAD BASED PAINT

The CONTRACTOR must comply with the regulations regarding lead-based paint found at 24 C.F.R. Part 35 on LEAD-BASED PAINT POISONING PREVENTION IN CERTAIN RESIDENTIAL STRUCTURES with regards to all housing units assisted using CDBG-DR funds.

45. VALUE ENGINEERING

(Applicable to construction contracts exceeding \$2,000 when required by Federal program legislation.)

The CONTRACTOR must comply with the regulations regarding systematic and organized approach to analyze functions of systems, equipment, facilities, services, and materials to ensure they achieve their essential functions at the lowest cost consistent to life cycle in execution, reliability, quality, and safety, in accordance with 24 C.F.R. § 200.318(g).

7W

WU

ATTACHMENT H

APPENDIX C CONTRACTOR CERTIFICATION FINANCIAL OVERSIGHT AND MANAGEMENT BOARD FOR PUERTO RICO CONTRACTS REVIEW POLICY

SYNERLUTION ENERGY, LLC.

The following is hereby certified to the Oversight Board regarding the request for authorization for **PV Systems, Water Cisterns Acquisition and Installation Services for the Community Energy and Water Resilience Installation Program** contract by and between the **Puerto Rico Department of Housing** and **Synerlution Energy, LLC.:**

1. The expected subcontractor(s) in connection with the proposed contract¹ is (are) the following:

N/A

2. Neither the contractor nor any of its owners², partners, directors, officials or employees, has agreed to share or give a percentage of the contractor's compensation under the contract to, or otherwise compensate, any third party, whether directly or indirectly, in connection with the procurement, negotiation, execution or performance of the contract, except as follows:

N/A

3. To the best knowledge of the signatory (after due investigation), no person has unduly intervened in the procurement, negotiation or execution of the contract, for its own benefit or that of a third person, in contravention of applicable law.

4. To the best knowledge of the signatory (after due investigation), no person has: (i) offered, paid, or promised to pay money to; (ii) offered, given, or promised to give anything of value to; or (iii) otherwise influenced any public official or employee with the purpose of securing any advantages, privileges or favors for the benefit of such person in connection with the contract (such as the execution of a subcontract with contractor, beneficial treatment under the contract, or the written or unwritten promise of a gift, favor, or other monetary or non-monetary benefit).

5. Neither the contractor, nor any of its owners, partners, directors, officials or employees or, to the best of its knowledge (after due investigation), its representatives or sub-contractors, has required, directly or indirectly, from third persons to take any action with

¹ As used herein, the term "contract" is inclusive of any amendments, modifications or extensions.

² For purposes of this certification, a contractor's "owner" shall mean any person or entity with more than a ten percent (10%) ownership interest in the contractor.

the purpose of influencing any public official or employee in connection with the procurement, negotiation or execution of the contract, in contravention of applicable law.

6. Any incorrect, incomplete or false statement made by the contractor's representative as part of this certification shall cause the nullity of the proposed contract and the contractor must reimburse immediately to the Commonwealth any amounts, payments or benefits received from the Commonwealth under the proposed contract.

"I hereby certify under penalty of perjury that the foregoing is complete, true and correct."

ZC

Signature

08/30/2021

Date

Irving Cruz Vadi

Printed Name

President
Position

700

WA



GOVERNMENT OF PUERTO RICO
DEPARTMENT OF HOUSING

ATTACHMENT I

GOVERNMENT OF PUERTO RICO

PROJECT LABOR AGREEMENT

BETWEEN

Puerto Rico Department of Housing (PRDOH)

AND

SYNERLUTION ENERGY, LLC

ARTICLE 1. —LEGAL BASIS

This Project Labor Agreement (hereinafter, "Agreement") is hereby adopted in accordance and in compliance with Section 3 of Administrative Bulletin No. OE-2018-033, titled "Executive Order of the Governor of Puerto Rico, Hon. Ricardo A. Rosselló Nevares, to increase minimum wage for construction workers, implement laws that require the use of cement produced in Puerto Rico, and require the use of labor agreements in construction projects paid using public funds", enacted on July 30, 2018 (hereinafter, "OE-2018-033").

ARTICLE 2. —PURPOSE

The Government of Puerto Rico wishes to contribute to the economic welfare of construction workers, increase peace in the workplace and employee safety, and promote efficient and punctual performance of the Construction Project, as defined in Article 4 of this Agreement, in such a way that complies with the public policy set forth in OE-2018-033. In accordance with Section 4 of OE-2018-033, this Agreement shall promote these objectives and it exclusively: binds all contractors and subcontractors who participate in the Construction Project; contains tools to avoid interruptions based on labor disputes; promotes harmony in the workplace; provides uniform mechanisms to solve labor conflicts, and increases cooperation between contractors and workers in matters related to productivity and occupational safety.

ARTICLE 3. —PARTIES TO THE AGREEMENT

This document is a Project Labor Agreement entered into by Puerto Rico Department of Housing (PRDOH), as agency of the Executive Branch of the Government of Puerto Rico (hereinafter, "Agency"), and GREEN ENERGY & FUELS, INC., as a contractor who employs construction workers for the Construction Project (hereinafter, "Contractor"). Project Labor Agreement (AGENCY AND CONTRACTOR)

ARTICLE 4. —CONSTRUCTION PROJECT

The Construction Project (hereinafter, "Construction Project") is described in the Agreement between PRDOH and the Contractor, to which this Project Labor Agreement is an attachment of.

ARTICLE 5. —RESPONSIBILITIES AND OBLIGATIONS OF THE PARTIES

This Agreement shall be binding on the Agency and on all Contractors at all levels who are part of the Construction Project, as defined in OE-2018-033 and Circular Letter No. 2018-01 of the Department of Labor and Human Resources (hereinafter, "DTRH" for its Spanish acronym). Contractors shall include a clause in any subcontract entered into during the term of this Agreement to the effect that their subcontractors, on all levels, shall be parties that are governed by this Agreement as to any work subcontracted within the scope of the Construction Project. Furthermore, all Contractors and subcontractors who are a part of the Construction Project, as defined in OE-2018-033 and DTRH Circular Letter No. 2018-01, shall include a clause in the contract in which they agree to comply with the provisions of this Agreement.

The Agency shall not be responsible for any violation of this Agreement. The Agency and any Contractor shall not be liable for violations to this Agreement committed by other Contractors. Liability of any Contractor under this Agreement shall be individual and shall not be joint liability ("mancomunada", in Spanish). The Agency and any Contractor shall not be liable for violations to this Agreement committed by another Contractor. It is further provided that the Contractor shall be responsible for compensating workers hired by subcontractors who did not comply with the minimum wage requirement.

7W
Nothing in this Article shall limit the exclusive discretion of the Agency to determine what Contractor to award contracts to for the Construction Project. The Agency retains the authority to totally or partially cancel, delay, or suspend the Construction Project.

In addition to the provisions of this Agreement, in the event that there is a collective bargaining agreement between the Contractor and an exclusive union representative of its employees, or a certification of a relevant forum establishing a labor union as the exclusive union representative of the workers or group of workers for the Contractor, the liability of the latter shall be governed as expressly agreed in the appropriate collective bargaining agreement and/or relevant case law of the National Labor Relations Board.

ARTICLE 6. —WAGES

UM
All workers covered by this Agreement shall be paid a wage of no less than fifteen dollars (\$15.00) per hour, in accordance with OE-2018-033, DTRH Circular Letter No. 2018-01 and Article 9 of this Agreement. In the event that the worker is entitled to earn a wage greater than what is contemplated under OE-2018-033, due to some federal or state law, the contractor and subcontractors shall be required to pay the higher wage. The Contractor shall put up the poster made by the DTRH as to minimum wage established under OE-2018-033 in a visible location in the Construction Project. It is further provided that the classification of a person as independent contractor shall not, in and of itself, be grounds to avoid the minimum wage provided under OE-2018-033.

As provided by Section 3 of Law No. 17 enacted on April 17, 1931, as amended, known as "Wage Payment Law", workers shall receive compensation either in cash, by check, direct deposit, transfer, or credit to a payroll card, in intervals that shall not exceed fifteen (15) days. When a worker is terminated or resigns from his or her

job during any day of the week, the Contractor shall pay the amount for the number of days worked, no later than the next official pay day in the manner agreed upon.

If the provisions of Law No. 379 enacted on May 15, 1948, as amended, known as the "Law to Establish Work Hours in Puerto Rico", is applicable because there is no collective bargaining agreement in effect negotiated by a labor organization, the Contractor shall provide each worker with a pay stub containing the following information: name and address of the Contractor, name of the employee, position, dates and period of work covered by the payment, total regular hours and overtime, salary earned for regular hours and overtime; additions and deductions, indicating the reasons therefor; and the net amount received by the worker. The employer shall provide, within five (5) calendar days subsequent to payment, a check stub through a method that guarantees delivery in accordance with Article XV of DTRH Regulation No. 9017 enacted on April 4, 2018, "Regulations to Administer Law No. 379 enacted on May 15, 1948, as amended, known as the 'Law to Establish Work Hours in Puerto Rico'".

The Parties reaffirm their policy of non-discrimination in the workplace based on any of the reasons prohibited by law, as well as public policy, intended to promote equal pay for equal work in accordance with Law 16-2017, "Puerto Rico Equal Salary Act," and Law 61-2017. Furthermore, the Contractor acknowledges that he or she has consulted the "Uniform Guidelines for Self-Study as to Equal Salary in the Workplace" of August 10, 2017, in order to make any internal assessment to corroborate that it does not engage in salary discrimination of its employees based on sex.

Every other aspect of the legislation and federal and state regulations regarding how minimum wage is paid and what is considered to be work hours or time shall be applicable.

ARTICLE 7. —PROCEEDINGS BEFORE THE LABOR AND HUMAN RESOURCES DEPARTMENT

Any worker covered by this Agreement, by the provisions of OE-2018-033 and by DTRH Circular Letter No. 2018-01, who alleges a violation of the wage provisions may contact the DTRH's Work Regulations Bureau to report the violation. The DTRH shall initiate an expedited process to hear these claims for prompt decision in accordance with the Secretary's Memorandum No. 2018-05.

The Contractor shall cooperate with the Investigators of the Work Regulations Bureau and with any other employee or officer granted authority by the Secretary of the DTRH to investigate these claims. Furthermore, the Contractor shall be required to deliver payroll documents, a copy of the contracts or any other documents requested by said employees and/or officers with delegated authority.

In accordance with Law 115-1991, as amended, the Contractor shall not be able to terminate, threaten, or discriminate against any worker in relation to the terms, conditions, compensation, location, benefits, or privileges of employment based on the worker offering or attempting to offer any verbal or written testimony, statement or information, related to the rights given by the OE-2018-033, before the DTRH or any other judicial, administrative, or legislative forum, if said statements are not defamatory or constitute a disclosure of privileged information established by law.

Nothing provided in this Article prevents workers from turning to the courts to enforce their rights, request any other legal remedies that are necessary to enforce the terms of the OE-2018-033, and compel compliance with the rules, orders, and determinations issued by the Secretary of the DTRH in the exercise of the powers given to the same under it.

ARTICLE 8. —DISPUTE RESOLUTION

The Contractor, as well as any other subcontractor, must take affirmative steps to solve labor controversies in order to avoid, but not prohibit, cessation of work, strikes, stoppages, or closures, which could put at risk the timely conclusion of the Construction Project. If, after attempting to solve the controversy internally, any of these conflicts materializes, both the Agency and the Contractor agree to notify the DTRH within a period of forty-eight (48) hours from conclusion of the internal resolution attempts. The DTRH shall send a DTRH mediator or arbitrator, within a period of two (2) business days from notice to the same, who shall attempt to solve the situation. The alternative conflict resolution process before the DTRH shall have priority and must be concluded within thirty (30) days from designation of the mediator or arbitrator.

7W Nothing provided in this Article prevents the parties from turning to any other judicial, administrative, or legislative forum to enforce their rights.

ARTICLE 9. —SAFETY AND PROTECTION REQUIREMENTS

At the Construction Project site, each Contractor must comply with and maintain the current safety requirements in accordance with the applicable state and federal rules and regulations, including the ones promulgated by the Puerto Rico Occupational Safety and Health Administration ("PR OSHA"), an entity under the DTRH.

Within sixty (60) days of signing the agreement, the Contractor must contact PR OSHA to request training regarding the occupational safety and health standards which must be implemented during the course of the Construction Project.

Furthermore, each Contractor must make sure that non-skillful workers ("obrerros no-diestros" in Spanish) participate in training programs regarding subjects that are relevant to the construction industry, related to construction codes, safety, permits, among others, in accordance with the procedures and guidelines issued by the Office of Management and Permits of the Government of Puerto Rico ("OGPe," for its acronym in Spanish) in this regard. Compliance with said training programs shall be an indispensable requirement for non-skillful workers to be able to continue earning the minimum salary of fifteen dollars (\$15.00) per hour provided in the OE-2018-033 and interpreted in DTRH Circular Letter No. 2018-01. It shall be the responsibility of each Contractor to comply with the duties and guidelines issued by the OGPe in this regard.

UM **ARTICLE 10. —UNIONS**

The implementation of the provisions of this Agreement shall not be considered as the recognition by the Contractor or the Agency of a labor union as the exclusive

union representative of any group of employees at the shop, in accordance with Section 9 of the OE-2018-033.

In the event that there is a collective bargaining agreement between the Contractor and an exclusive union representative of its employees, or a certification from a relevant forum establishing a labor union as the exclusive union representative of the workers or group of workers of the Contractor, it shall be the responsibility of the latter to negotiate work conditions and the controversy resolution process with the union representative. Therefore, the relationship between the Contractor and the workers shall be governed by the specific agreements in the corresponding collective bargaining agreement and/or relevant case law of the National Labor Relations Board, in all parts and sections that are not incompatible with the Agreement.

ARTICLE 11. —APPLICABILITY TO EMPLOYEES

The provisions of this agreement apply to all (skillful or non-skillful ("diestro o no diestro", in Spanish) construction workers who perform manual or physical duties in the Construction Project, as defined in the OE-2018-033 and the DTRH Circular Letter No. 2018-01. The following persons are not subject to the provisions of this Agreement, even if they perform Construction Project duties:

70

a. "Professionals", "executives", and "administrators", as defined by the Regulations of the DTRH No. 7082 dated January 18, 2006, known as "Regulation Number 13 — Fifth Revision (2005)."

b. Employees who do not directly perform manual or physical duties in the Construction Project, only performing duties in connection to public work, such as: security/surveillance area monitors, timekeepers, mailpersons, office works, secretaries, messengers, guards, accounting duties (payroll, bookkeeping), technicians, receptionists, switchboard operators, electronic data processing, record keepers, and other analogous duties, and all other employees who only perform administrative duties.

c. Employees of the Agency, or of any other state entity, even if they work at the Construction Project site while it is in progress.

ARTICLE 12. —APPLICABILITY TO ENTITIES

This Agreement shall be available and shall be fully applied to any winning bidder for the Construction Project who becomes the signer of the same, regardless of whether or not it performs work in other projects. This Agreement shall not apply to the work of any Contractor performed in other projects. Furthermore, it shall not apply to the headquarters, subsidiaries, or affiliates of any Contractor, which does not participate in the Construction Project directly.

AW

Work conditions under this Agreement shall not apply to the Agency, nor to any other public entity, and nothing contained in this document shall be interpreted to prohibit its employees from working in or outside of the Construction Project location.

ARTICLE 13. —SEVERABILITY

If any part of this Agreement is nullified, found to violate the law, or to potentially result in the loss of all or part of the Construction Project financing, it shall be considered temporarily or permanently null and void. However, the rest of the Agreement shall remain in full force and effect to the extent allowed by law. It is the express and unequivocal will of the Parties that the corresponding forums enforce the provisions and the application of this Agreement to the greatest extent possible, even if any part of it, or its application to any person or circumstance, is revoked, nullified, invalidated, affected, or declared unconstitutional.

ARTICLE 14. –EXCLUSIVITY OF AGREEMENTS

This document contains the only agreements of all signers in relation to the labor conditions governing the Construction Project and replace any other agreement between the parties regarding labor conditions which would otherwise completely or partially apply to the Construction Project. It shall not be required for any Contractor to execute another agreement regarding labor conditions as a requirement to carry out Construction Project.

ARTICLE 15. –EFFECTIVE PERIOD

rw
This Agreement shall come into effect immediately upon being approved and signed by (1) the Agency appointing authority and (2) the Contractor. It is understood that this Agreement, along with all of its provisions, shall remain in effect for the entire Construction Project until it is concluded, even if it is not completed before the agreement expiration date.

AND SINCE THEY ARE IN AGREEMENT AS TO THE FOREGOING, the parties sign this Agreement on December 15, 2021.

hr
DEPARTMENT OF HOUSING



William O. Rodríguez Rodríguez, Esq.,
Secretary

SYNERLUTION ENERGY, LLC



Irving Cruz Vadi
Managing Director

Federal Labor Standards Provisions

U.S. Department of Housing
and Urban Development
Office of Labor Relations

Applicability

The Project or Program to which the construction work covered by this contract pertains is being assisted by the United States of America and the following Federal Labor Standards Provisions are included in this Contract pursuant to the provisions applicable to such Federal assistance.

A. 1. (i) Minimum Wages. All laborers and mechanics employed or working upon the site of the work, will be paid unconditionally and not less often than once a week, and without subsequent deduction or rebate on any account (except such payroll deductions as are permitted by regulations issued by the Secretary of Labor under the Copeland Act (29 CFR Part 3), the full amount of wages and bona fide fringe benefits (or cash equivalents thereof) due at time of payment computed at rates not less than those contained in the wage determination of the Secretary of Labor which is attached hereto and made a part hereof, regardless of any contractual relationship which may be alleged to exist between the contractor and such laborers and mechanics. Contributions made or costs reasonably anticipated for bona fide fringe benefits under Section 1(b)(2) of the Davis-Bacon Act on behalf of laborers or mechanics are considered wages paid to such laborers or mechanics, subject to the provisions of 29 CFR 5.5(a)(1)(iv); also, regular contributions made or costs incurred for more than a weekly period (but not less often than quarterly) under plans, funds, or programs, which cover the particular weekly period, are deemed to be constructively made or incurred during such weekly period.

Such laborers and mechanics shall be paid the appropriate wage rate and fringe benefits on the wage determination for the classification of work actually performed, without regard to skill, except as provided in 29 CFR 5.5(a)(4). Laborers or mechanics performing work in more than one classification may be compensated at the rate specified for each classification for the time actually worked therein: Provided, That the employer's payroll records accurately set forth the time spent in each classification in which work is performed. The wage determination (including any additional classification and wage rates conformed under 29 CFR 5.5(a)(1)(ii) and the Davis-Bacon poster (WH-1321) shall be posted at all times by the contractor and its subcontractors at the site of the work in a prominent and accessible, place where it can be easily seen by the workers.

(ii) (a) Any class of laborers or mechanics which is not listed in the wage determination and which is to be employed under the contract shall be classified in conformance with the wage determination. HUD shall approve an additional classification and wage rate and fringe benefits therefor only when the following criteria have been met:

(1) The work to be performed by the classification requested is not performed by a classification in the wage determination; and

(2) The classification is utilized in the area by the construction industry; and

(3) The proposed wage rate, including any bona fide fringe benefits, bears a reasonable relationship to the wage rates contained in the wage determination.

(b) If the contractor and the laborers and mechanics to be employed in the classification (if known), or their representatives, and HUD or its designee agree on the classification and wage rate (including the amount designated for fringe benefits where appropriate), a report of the action taken shall be sent by HUD or its designee to the Administrator of the Wage and Hour Division, Employment Standards Administration, U.S. Department of Labor, Washington, D.C. 20210. The Administrator, or an authorized representative, will approve, modify, or disapprove every additional classification action within 30 days of receipt and so advise HUD or its designee or will notify HUD or its designee within the 30-day period that additional time is necessary. (Approved by the Office of Management and Budget under OMB control number 1215-0140.)

(c) In the event the contractor, the laborers or mechanics to be employed in the classification or their representatives, and HUD or its designee do not agree on the proposed classification and wage rate (including the amount designated for fringe benefits, where appropriate), HUD or its designee shall refer the questions, including the views of all interested parties and the recommendation of HUD or its designee, to the Administrator for determination. The Administrator, or an authorized representative, will issue a determination within 30 days of receipt and so advise HUD or its designee or will notify HUD or its designee within the 30-day period that additional time is necessary. (Approved by the Office of Management and Budget under OMB Control Number 1215-0140.)

(d) The wage rate (including fringe benefits where appropriate) determined pursuant to subparagraphs (1)(ii)(b) or (c) of this paragraph, shall be paid to all workers performing work in the classification under this contract from the first day on which work is performed in the classification.

(iii) Whenever the minimum wage rate prescribed in the contract for a class of laborers or mechanics includes a fringe benefit which is not expressed as an hourly rate, the contractor shall either pay the benefit as stated in the wage determination or shall pay another bona fide fringe benefit or an hourly cash equivalent thereof.

(iv) If the contractor does not make payments to a trustee or other third person, the contractor may consider as part

Handwritten initials

of the wages of any laborer or mechanic the amount of any costs reasonably anticipated in providing bona fide fringe benefits under a plan or program. Provided, That the Secretary of Labor has found, upon the written request of the contractor, that the applicable standards of the Davis-Bacon Act have been met. The Secretary of Labor may require the contractor to set aside in a separate account assets for the meeting of obligations under the plan or program. (Approved by the Office of Management and Budget under OMB Control Number 1215-0140.)

70

2. Withholding. HUD or its designee shall upon its own action or upon written request of an authorized representative of the Department of Labor withhold or cause to be withheld from the contractor under this contract or any other Federal contract with the same prime contractor, or any other Federally-assisted contract subject to Davis-Bacon prevailing wage requirements, which is held by the same prime contractor so much of the accrued payments or advances as may be considered necessary to pay laborers and mechanics, including apprentices, trainees and helpers, employed by the contractor or any subcontractor the full amount of wages required by the contract in the event of failure to pay any laborer or mechanic, including any apprentice, trainee or helper, employed or working on the site of the work, all or part of the wages required by the contract, HUD or its designee may, after written notice to the contractor, sponsor, applicant, or owner, take such action as may be necessary to cause the suspension of any further payment, advance, or guarantee of funds until such violations have ceased. HUD or its designee may, after written notice to the contractor, disburse such amounts withheld for and on account of the contractor or subcontractor to the respective employees to whom they are due. The Comptroller General shall make such disbursements in the case of direct Davis-Bacon Act contracts.

3. (i) Payrolls and basic records. Payrolls and basic records relating thereto shall be maintained by the contractor during the course of the work preserved for a period of three years thereafter for all laborers and mechanics working at the site of the work. Such records shall contain the name, address, and social security number of each such worker, his or her correct classification, hourly rates of wages paid (including rates of contributions or costs anticipated for bona fide fringe benefits or cash equivalents thereof of the types described in Section 1(b)(2)(B) of the Davis-bacon Act), daily and weekly number of hours worked, deductions made and actual wages paid. Whenever the Secretary of Labor has found under 29 CFR 5.5 (a)(1)(iv) that the wages of any laborer or mechanic include the amount of any costs reasonably anticipated in providing benefits under a plan or program described in Section 1(b)(2)(B) of the Davis-Bacon Act, the contractor shall maintain records which show that the commitment to provide such benefits is enforceable, that the plan or program is financially responsible, and that the plan or program has been

communicated in writing to the laborers or mechanics affected, and records which show the costs anticipated or the actual cost incurred in providing such benefits. Contractors employing apprentices or trainees under approved programs shall maintain written evidence of the registration of apprenticeship programs and certification of trainee programs, the registration of the apprentices and trainees, and the ratios and wage rates prescribed in the applicable programs. (Approved by the Office of Management and Budget under OMB Control Numbers 1215-0140 and 1215-0017.)

(ii) (a) The contractor shall submit weekly for each week in which any contract work is performed a copy of all payrolls to HUD or its designee if the agency is a party to the contract, but if the agency is not such a party, the contractor will submit the payrolls to the applicant sponsor, or owner, as the case may be, for transmission to HUD or its designee. The payrolls submitted shall set out accurately and completely all of the information required to be maintained under 29 CFR 5.5(a)(3)(i) except that full social security numbers and home addresses shall not be included on weekly transmittals. Instead the payrolls shall only need to include an individually identifying number for each employee (e.g., the last four digits of the employee's social security number). The required weekly payroll information may be submitted in any form desired. Optional Form WH-347 is available for this purpose from the Wage and Hour Division Web site at <http://www.dol.gov/esa/whd/forms/wh347instr.htm> or its successor site. The prime contractor is responsible for the submission of copies of payrolls by all subcontractors. Contractors and subcontractors shall maintain the full social security number and current address of each covered worker, and shall provide them upon request to HUD or its designee if the agency is a party to the contract, but if the agency is not such a party, the contractor will submit the payrolls to the applicant sponsor, or owner, as the case may be, for transmission to HUD or its designee, the contractor, or the Wage and Hour Division of the Department of Labor for purposes of an investigation or audit of compliance with prevailing wage requirements. It is not a violation of this subparagraph for a prime contractor to require a subcontractor to provide addresses and social security numbers to the prime contractor for its own records, without weekly submission to HUD or its designee. (Approved by the Office of Management and Budget under OMB Control Number 1215-0149.)

(b) Each payroll submitted shall be accompanied by a "Statement of Compliance," signed by the contractor or subcontractor or his or her agent who pays or supervises the payment of the persons employed under the contract and shall certify the following:

(1) That the payroll for the payroll period contains the information required to be provided under 29 CFR 5.5 (a)(3)(ii), the appropriate information is being maintained under 29 CFR 5.5(a)(3)(i), and that such information is correct and complete;

MS

(2) That each laborer or mechanic (including each helper, apprentice, and trainee) employed on the contract during the payroll period has been paid the full weekly wages earned, without rebate, either directly or indirectly, and that no deductions have been made either directly or indirectly from the full wages earned, other than permissible deductions as set forth in 29 CFR Part 3;

(3) That each laborer or mechanic has been paid not less than the applicable wage rates and fringe benefits or cash equivalents for the classification of work performed, as specified in the applicable wage determination incorporated into the contract.

(c) The weekly submission of a properly executed certification set forth on the reverse side of Optional Form WH-347 shall satisfy the requirement for submission of the "Statement of Compliance" required by subparagraph A.3.(ii)(b).

(d) The falsification of any of the above certifications may subject the contractor or subcontractor to civil or criminal prosecution under Section 1001 of Title 18 and Section 231 of Title 31 of the United States Code.

(iii) The contractor or subcontractor shall make the records required under subparagraph A.3.(i) available for inspection, copying, or transcription by authorized representatives of HUD or its designee or the Department of Labor, and shall permit such representatives to interview employees during working hours on the job. If the contractor or subcontractor fails to submit the required records or to make them available, HUD or its designee may, after written notice to the contractor, sponsor, applicant or owner, take such action as may be necessary to cause the suspension of any further payment, advance, or guarantee of funds. Furthermore, failure to submit the required records upon request or to make such records available may be grounds for debarment action pursuant to 29 CFR 5.12.

4. Apprentices and Trainees.

(i) **Apprentices.** Apprentices will be permitted to work at less than the predetermined rate for the work they performed when they are employed pursuant to and individually registered in a bona fide apprenticeship program registered with the U.S. Department of Labor, Employment and Training Administration, Office of Apprenticeship Training, Employer and Labor Services, or with a State Apprenticeship Agency recognized by the Office, or if a person is employed in his or her first 90 days of probationary employment as an apprentice in such an apprenticeship program, who is not individually registered in the program, but who has been certified by the Office of Apprenticeship Training, Employer and Labor Services or a State Apprenticeship Agency (where appropriate) to be eligible for probationary employment as an apprentice. The allowable ratio of apprentices to journeymen on the job site in any craft classification shall not be greater than the ratio permitted to the contractor as to the entire work force under the registered program. Any worker listed on a payroll at an apprentice wage rate, who

is not registered or otherwise employed as stated above, shall be paid not less than the applicable wage rate on the wage determination for the classification of work actually performed. In addition, any apprentice performing work on the job site in excess of the ratio permitted under the registered program shall be paid not less than the applicable wage rate on the wage determination for the work actually performed. Where a contractor is performing construction on a project in a locality other than that in which its program is registered, the ratios and wage rates (expressed in percentages of the journeyman's hourly rate) specified in the contractor's or subcontractor's registered program shall be observed. Every apprentice must be paid at not less than the rate specified in the registered program for the apprentice's level of progress, expressed as a percentage of the journeymen hourly rate specified in the applicable wage determination. Apprentices shall be paid fringe benefits in accordance with the provisions of the apprenticeship program. If the apprenticeship program does not specify fringe benefits, apprentices must be paid the full amount of fringe benefits listed on the wage determination for the applicable classification. If the Administrator determines that a different practice prevails for the applicable apprentice classification, fringes shall be paid in accordance with that determination. In the event the Office of Apprenticeship Training, Employer and Labor Services, or a State Apprenticeship Agency recognized by the Office, withdraws approval of an apprenticeship program, the contractor will no longer be permitted to utilize apprentices at less than the applicable predetermined rate for the work performed until an acceptable program is approved.

(ii) **Trainees.** Except as provided in 29 CFR 5.16, trainees will not be permitted to work at less than the predetermined rate for the work performed unless they are employed pursuant to and individually registered in a program which has received prior approval, evidenced by formal certification by the U.S. Department of Labor, Employment and Training Administration. The ratio of trainees to journeymen on the job site shall not be greater than permitted under the plan approved by the Employment and Training Administration. Every trainee must be paid at not less than the rate specified in the approved program for the trainee's level of progress, expressed as a percentage of the journeyman hourly rate specified in the applicable wage determination. Trainees shall be paid fringe benefits in accordance with the provisions of the trainee program. If the trainee program does not mention fringe benefits, trainees shall be paid the full amount of fringe benefits listed on the wage determination unless the Administrator of the Wage and Hour Division determines that there is an apprenticeship program associated with the corresponding journeyman wage rate on the wage determination which provides for less than full fringe benefits for apprentices. Any employee listed on the payroll at a trainee rate who is not registered and participating in a training plan approved by

the Employment and Training Administration shall be paid not less than the applicable wage rate on the wage determination for the work actually performed. In addition, any trainee performing work on the job site in excess of the ratio permitted under the registered program shall be paid not less than the applicable wage rate on the wage determination for the work actually performed. In the event the Employment and Training Administration withdraws approval of a training program, the contractor will no longer be permitted to utilize trainees at less than the applicable predetermined rate for the work performed until an acceptable program is approved.

(iii) **Equal employment opportunity.** The utilization of apprentices, trainees and journeymen under 29 CFR Part 5 shall be in conformity with the equal employment opportunity requirements of Executive Order 11246, as amended, and 29 CFR Part 30.

5. Compliance with Copeland Act requirements. The contractor shall comply with the requirements of 29 CFR Part 3 which are incorporated by reference in this contract

6. Subcontracts. The contractor or subcontractor will insert in any subcontracts the clauses contained in subparagraphs 1 through 11 in this paragraph A and such other clauses as HUD or its designee may by appropriate instructions require, and a copy of the applicable prevailing wage decision, and also a clause requiring the subcontractors to include these clauses in any lower tier subcontracts. The prime contractor shall be responsible for the compliance by any subcontractor or lower tier subcontractor with all the contract clauses in this paragraph.

7. Contract termination; debarment. A breach of the contract clauses in 29 CFR 5.5 may be grounds for termination of the contract and for debarment as a contractor and a subcontractor as provided in 29 CFR 5.12.

8. Compliance with Davis-Bacon and Related Act Requirements. All rulings and interpretations of the Davis-Bacon and Related Acts contained in 29 CFR Parts 1, 3, and 5 are herein incorporated by reference in this contract

9. Disputes concerning labor standards. Disputes arising out of the labor standards provisions of this contract shall not be subject to the general disputes clause of this contract. Such disputes shall be resolved in accordance with the procedures of the Department of Labor set forth in 29 CFR Parts 5, 6, and 7. Disputes within the meaning of this clause include disputes between the contractor (or any of its subcontractors) and HUD or its designee, the U.S. Department of Labor, or the employees or their representatives.

10. (i) Certification of Eligibility. By entering into this contract the contractor certifies that neither it (nor he or she) nor any person or firm who has an interest in the contractor's firm is a person or firm ineligible to be awarded Government contracts by virtue of Section 3(a) of the Davis-Bacon Act or 29 CFR 5.12(a)(1) or to be

awarded HUD contracts or participate in HUD programs pursuant to 24 CFR Part 24.

(ii) No part of this contract shall be subcontracted to any person or firm ineligible for award of a Government contract by virtue of Section 3(a) of the Davis-Bacon Act or 29 CFR 5.12(a)(1) or to be awarded HUD contracts or participate in HUD programs pursuant to 24 CFR Part 24.

(iii) The penalty for making false statements is prescribed in the U.S. Criminal Code, 18 U.S.C. 1001. Additionally, U.S. Criminal Code, Section 1 01 0, Title 18, U.S.C., "Federal Housing Administration transactions", provides in part: "Whoever, for the purpose of . . . influencing in any way the action of such Administration..... makes, utters or publishes any statement knowing the same to be false..... shall be fined not more than \$5,000 or imprisoned not more than two years, or both."

11. Complaints, Proceedings, or Testimony by Employees. No laborer or mechanic to whom the wage, salary, or other labor standards provisions of this Contract are applicable shall be discharged or in any other manner discriminated against by the Contractor or any subcontractor because such employee has filed any complaint or instituted or caused to be instituted any proceeding or has testified or is about to testify in any proceeding under or relating to the labor standards applicable under this Contract to his employer.

B. Contract Work Hours and Safety Standards Act. The provisions of this paragraph B are applicable where the amount of the prime contract exceeds \$100,000. As used in this paragraph, the terms "laborers" and "mechanics" include watchmen and guards.

(1) Overtime requirements. No contractor or subcontractor contracting for any part of the contract work which may require or involve the employment of laborers or mechanics shall require or permit any such laborer or mechanic in any workweek in which the individual is employed on such work to work in excess of 40 hours in such workweek unless such laborer or mechanic receives compensation at a rate not less than one and one-half times the basic rate of pay for all hours worked in excess of 40 hours in such workweek.

(2) Violation; liability for unpaid wages; liquidated damages. In the event of any violation of the clause set forth in subparagraph (1) of this paragraph, the contractor and any subcontractor responsible therefor shall be liable for the unpaid wages. In addition, such contractor and subcontractor shall be liable to the United States (in the case of work done under contract for the District of Columbia or a territory, to such District or to such territory), for liquidated damages. Such liquidated damages shall be computed with respect to each individual laborer or mechanic, including watchmen and guards, employed in violation of the clause set forth in subparagraph (1) of this paragraph, in the sum of \$10 for each calendar day on which such individual was required or permitted to work in excess of the standard workweek of 40 hours without payment of the overtime wages required by the clause set forth in subparagraph (1) of this paragraph.

(3) Withholding for unpaid wages and liquidated damages. HUD or its designee shall upon its own action or upon written request of an authorized representative of the Department of Labor withhold or cause to be withheld, from any moneys payable on account of work performed by the contractor or subcontractor under any such contract or any other Federal contract with the same prime contract, or any other Federally-assisted contract subject to the Contract Work Hours and Safety Standards Act which is held by the same prime contractor such sums as may be determined to be necessary to satisfy any liabilities of such contractor or subcontractor for unpaid wages and liquidated damages as provided in the clause set forth in subparagraph (2) of this paragraph.

(4) Subcontracts. The contractor or subcontractor shall insert in any subcontracts the clauses set forth in subparagraph (1) through (4) of this paragraph and also a clause requiring the subcontractors to include these clauses in any lower tier subcontracts. The prime contractor shall be responsible for compliance by any subcontractor or lower tier subcontractor with the clauses set forth in subparagraphs (1) through (4) of this paragraph.

C. Health and Safety. The provisions of this paragraph C are applicable where the amount of the prime contract exceeds \$100,000.

7W
(1) No laborer or mechanic shall be required to work in surroundings or under working conditions which are unsanitary, hazardous, or dangerous to his health and safety as determined under construction safety and health standards promulgated by the Secretary of Labor by regulation.

(2) The Contractor shall comply with all regulations issued by the Secretary of Labor pursuant to Title 29 Part 1926 and failure to comply may result in imposition of sanctions pursuant to the Contract Work Hours and Safety Standards Act, (Public Law 91-54, 83 Stat 96). 40 USC 3701 et seq.

(3) The contractor shall include the provisions of this paragraph in every subcontract so that such provisions will be binding on each subcontractor. The contractor shall take such action with respect to any subcontractor as the Secretary of Housing and Urban Development or the Secretary of Labor shall direct as a means of enforcing such provisions.

Aplicabilidad

El proyecto o programa al que pertenece la obra de construcción objeto de este contrato recibe la asistencial de los Estados Unidos de América y las siguientes Disposiciones Federales sobre Normas Laborales se incluyen en este contrato, de conformidad con las disposiciones que correspondan para dicha asistencia federal.

A. 1. (i) Salarios mínimos. Todos los obreros y mecánicos empleados o que trabajen en el sitio de la obra recibirán un pago incondicional y no menos de una vez por semana, y sin una deducción o reembolso posteriores de o a cuenta alguna (excepto las deducciones de nómina permitidas por normatividad que dicte el Secretario del Trabajo con apego a la ley Copeland [Parte 3 del 29 del Código de Regulaciones Federales o CFR, por sus siglas en inglés]), el monto total de los salarios y prestaciones laborales marginales (o sus equivalentes en efectivo) adeudados al momento del pago, calculados a tasas no inferiores a las que figuran en la determinación salarial del Secretario de Trabajo que se adjunta e integra al presente, independientemente de cualquier relación contractual que pudiera presumirse que existe entre el contratista y tales obreros y mecánicos. Las contribuciones hechas o los costos razonablemente anticipados para las prestaciones laborales marginales conforme a la Sección I (b)(2) de la ley de Davis-Bacon en favor de los obreros o los mecánicos, se consideran como salarios pagados a tales trabajadores o mecánicos, con apego a las disposiciones de la sección 5.5(a)(1)(iv) del 29 del CFR; además, las contribuciones corrientes hechas o los costos incurridos por más de un período semanal (pero no con menos frecuencia que trimestralmente) al amparo de planes, fondos o programas que comprendan el período semanal específico, implícitamente se consideran como hechas o incurridas durante dicho período semanal.

A tales obreros y mecánicos se les pagarán la tasa salarial y las prestaciones laborales marginales de la determinación salarial para la clasificación del trabajo de hecho realizado, independientemente de la destreza, excepto según lo dispuesto en la 5.5(a)(4) del 29 del CFR. Los obreros o mecánicos que realicen trabajo que corresponda a más de una clasificación pueden compensarse a la tasa especificada para cada clasificación por el tiempo de hecho trabajado en ellas: siempre y cuando los registros de nómina del empleador establezcan con precisión el tiempo dedicado a cada clasificación en la que el trabajo se realiza. En todo momento, el contratista y sus subcontratistas mantendrán colocada la determinación salarial (incluyendo cualquier clasificación y tasa salarial adicionales conformadas al amparo de la sección 5.5(a)(1)(ii) del 29 del CFR y el cartel de la ley Davis-Bacon, WH-1321) en el sitio de la obra, en un lugar prominente y accesible donde los trabajadores puedan verlo con facilidad.

(ii) (a) Toda clase de obreros o mecánicos que no esté indicada en la determinación salarial y que deba emplearse al amparo del contrato se clasificará de conformidad con la determinación salarial. El Departamento de Vivienda y Desarrollo Urbano (HUD, por sus siglas en inglés) aprobará una clasificación adicional, y la tasa salarial y las prestaciones laborales marginales de la misma, únicamente cuando se hayan satisfecho los siguientes criterios:

(1) El trabajo a realizarse en virtud de la clasificación solicitada no se realiza en virtud de una clasificación de la determinación salarial; y

(2) La industria de la construcción utiliza la clasificación en la zona; y

(3) La tasa salarial propuesta, incluyendo toda prestación laboral marginal, tiene una relación razonable con las tasas salariales contenidas en la determinación salarial.

(b) Si el contratista, los obreros y los mecánicos a emplearse dentro de la clasificación (si se conoce), o sus representantes, y el HUD o su delegado se ponen de acuerdo en cuanto a la clasificación y la tasa salarial (incluyendo el monto designado para prestaciones laborales marginales, cuando así corresponda), se enviará un informe sobre la medida tomada al HUD o a su delegado, a: Administrator of the Wage and Hour Division, Employment Standards Administration, U.S. Department of Labor, Washington, D.C. 20210. El Administrador, o un representante autorizado, aprobará, modificará o desaprobará cada medida de clasificación adicional en un plazo de 30 días a partir de su recibo, y así se lo hará saber al HUD o a su delegado, o les notificará dentro de ese período de 30 días que necesita tiempo adicional (aprobado por la Oficina de Administración y Presupuesto, con el número de control 1215-0140).

(c) En caso de que el contratista, los obreros o los mecánicos empleados dentro de la clasificación, o sus representantes, y el HUD o su delegado no se pongan de acuerdo en cuanto a la clasificación propuesta y la tasa salarial (incluyendo el monto designado para las prestaciones laborales marginales, cuando así corresponda), el HUD o su delegado remitirán al Administrador las preguntas, incluyendo su recomendación y las opiniones de todas las partes interesadas, para que tome una determinación. El Administrador, o un representante autorizado, dictará una determinación en un plazo de 30 días a partir de su recibo, y así se lo hará saber al HUD o a su delegado, o les notificará dentro de ese período de 30 días que necesita tiempo adicional (aprobado por la Oficina de Administración y Presupuesto, con el número de control 1215-0140).

(d) La tasa salarial (incluyendo las prestaciones laborales marginales, cuando así corresponda) determinada de conformidad con los subincisos (1)(ii)(b) o (c) de este apartado, se pagará a todos los trabajadores que desempeñen un trabajo dentro de la clasificación que contemple este contrato, desde el primer día en el que se realicen trabajos dentro de la clasificación.

(iii) Siempre que el salario mínimo prescrito en el contrato para una clase dada de obreros o mecánicos incluye una prestación laboral marginal que no se expresa en la forma de una tarifa por hora, el contratista pagará la prestación como se indica en la determinación salarial, o pagará otra prestación laboral marginal o su equivalente en efectivo por hora.

(iv) Si no realiza pagos a un fideicomisario u otro tercero, el contratista puede considerar como parte del salario de cualquier obrero o mecánico el importe de todo costo que razonablemente se anticipe en la prestación de prestaciones laborales marginales al amparo de un plan o programa, siempre y cuando el Secretario del Trabajo haya

determinado, a solicitud por escrito del contratista, que se cumplió con las normas correspondiente de la ley Davis-Bacon. El Secretario del Trabajo puede exigir que el contratista reserve en una cuenta aparte, recursos para satisfacción de la obligaciones conforme al plan o programa (aprobado por la Oficina de Administración y Presupuesto, con el número de control 1215-0140).

2. **Retención.** El HUD o su delegado, a su propio recurso o al solicitarlo por escrito un representante autorizado del Departamento del Trabajo, retendrán o verán que se le retenga al contratista, con apego a este o a cualquier otro contrato federal que se tenga con el mismo contratista principal, o a cualquier otro contrato que reciba asistencia federal en virtud de los requisitos salariales de la ley Davis-Bacon imperantes y que tenga el mismo contratista principal, tanto de los pagos o adelantos acumulados como se considere necesario para pagar a los obreros y mecánicos (incluidos los aprendices, trabajadores en capacitación y ayudantes) empleados por el contratista o por cualquier subcontratista el importe total de los salarios que exija el contrato, en caso de que no pague a alguno de ellos que esté empleado o trabajando en el sitio de la obra, nada o parte de los salarios que exija el contrato. El HUD o su delegado pueden, tras dar aviso por escrito al contratista, promotor, solicitante o propietario, actuar del modo que pudiera ser necesario para suscitar la suspensión de cualquier otro pago, adelanto o promesa de fondos adicionales, hasta que cesen tales contravenciones. El HUD o su delegado pueden, tras dar aviso por escrito al contratista, desembolsar dichos montos retenidos por y a cuenta del contratista o subcontratista a los empleados respectivos a quienes se los adeudan. La Contraloría General hará tales desembolsos en el caso de los contratos directos de la ley Davis-Bacon.

3. **(i) Nóminas y registros básicos.** Las nóminas y los registros básicos relacionados con ellas serán llevados por el contratista durante el transcurso de la obra y a conservarse por un período de tres años después para todos los obreros y mecánicos que trabajen en el sitio de la obra. Dichos registros contendrán el nombre, la dirección y el número de Seguro Social de cada trabajador tal, así como su clasificación correcta, salario pagado por hora (incluyendo las tasas de las contribuciones o costos anticipados para las prestaciones laborales marginales o sus equivalentes en efectivo, de los tipos descritos en la sección l(b)(2)(B) de la ley Davis-Bacon), el número diario y semanal de horas trabajadas, las deducciones hechas, y los salarios reales pagados. Siempre que el Secretario del Trabajo determine, conforme a la sección 5.5(a)(1)(iv) del 29 del CFR, que los salarios de un obrero o mecánico incluyen el monto de algún costo razonablemente anticipado en la prestación de prestaciones al amparo de un plan o programa que se describa en la Sección l(b)(2)(B) de la Ley Davis-Bacon, el contratista mantendrá registros que demuestren que la promesa de prestarlos es exigible, que el plan o programa es financieramente responsable, y que el plan o programase les ha comunicado por escrito a los obreros o mecánicos afectados, así como registros que indiquen los costos anticipados o el costo real incurrido en su prestación. Los contratistas que emplean aprendices o

trabajadores en capacitación al amparo de programas aprobados mantendrán pruebas escritas del registro de los programas para aprendices y la certificación de aquellos para trabajadores en capacitación, el registro de los aprendices y trabajadores en capacitación, y las proporciones y tasas salariales prescritas en los programas pertinentes (aprobado por la Oficina de Administración y Presupuesto, con los números de control 1215-0140 y 1215-0017).

(ii) **(a)** El contratista remitirá semanalmente, por cada semana en la que se realice algún trabajo del contrato, una copia de todas las nóminas al HUD, o a su delegado si la entidad es una de las partes del contrato; pero si no lo es, el contratista remitirá las nóminas al solicitante, promotor o propietario, según sea el caso, para su subsiguiente remisión al HUD o a su delegado. Las nóminas remitidas establecerán con precisión y a cabalidad toda la información que deba mantenerse conforme a la sección 5.5(a)(3)(i) del 29 del CFR, excepto que no se incluirán números de Seguro Social ni domicilios completos en las remisiones semanales. En cambio, las nóminas solo deberán incluir un número de identificación individual para cada empleado (por ejemplo, los últimos cuatro dígitos de su número de Seguro de Social). Los datos de nómina semanales necesarios pueden enviarse de cualquier forma que se desee. El formulario opcional WH-347 está disponible para este propósito en el sitio de internet de la Sección de Salarios y Horarios Laborales, en <http://www.dol.gov/esa/whd/forms/wh347instr.htm>, o en el sitio que le sigue. El contratista principal es responsable de presentar copias de las nóminas de todos los subcontratistas. Los contratistas y subcontratistas mantendrán el número de Seguro Social completo y la dirección actual de cada uno de los trabajadores contemplados, y deberán proporcionarlos al HUD o a su delegado cuando se le soliciten si la entidad es una de las partes del contrato, pero si no es una parte tal, el contratista remitirá las nóminas al solicitante, promotor o propietario, según sea el caso, para su remisión subsiguiente al HUD o su delegado, al contratista, o a la Sección de Salarios y Horarios Laborales del Departamento de Trabajo para fines de una investigación o auditoría sobre la observancia de los requisitos salariales vigentes. Que un contratista principal exija a un subcontratista que le proporcione las direcciones y números de Seguro Social para incluirlos en los registros propios, sin una remisión semanal al HUD o a su delegado, no constituye una contravención de este subinciso (aprobado por la Oficina de Administración y Presupuesto, con el número de control 1215-0149).

(b) Cada nómina remitida deberá ir acompañada de una "Declaración de Cumplimiento" firmada por el contratista o subcontratista (o su representante) que paga o supervisa el pago de las personas empleadas en virtud del contrato, y deberá certificar lo siguiente:

(1) que la nómina para el período de nómina contiene la información que debe proporcionarse conforme a la sección 5.5(a)(3)(ii) del 29 del CFR, que la información debida se mantiene conforme a la sección 5.5(a)(3)(i) del 29 del CFR, y que dicha información es correcta y completa;

(2) que a cada obrero o mecánico (incluyendo cada ayudante, aprendiz y trabajador en capacitación) empleados en el contrato durante el período de nómina se le ha pagado el salario semanal devengado completo, sin descuentos, ya sean directos o indirectos, y que no se ha realizado ninguna deducción directa ni indirecta de los salarios devengados completos, aparte de las permitidas según se establece en la Parte 3 del 29 del CFR; y

(3) que a cada obrero o mecánico se le ha pagado no menos de la tasa salarial y las prestaciones laborales marginales correspondientes, o su equivalente en efectivo para la clasificación que corresponde al trabajo realizado, como se especifica en la determinación salarial pertinente incorporada al contrato.

(c) La presentación semanal de una certificación debidamente firmada que se establece al reverso del formulario opcional WH-347 satisfará el requisito de remisión de la "Declaración de Cumplimiento" que exige el subinciso A.3.(ii)(b).

(d) La falsificación de cualquiera de las certificaciones anteriores puede hacer al contratista o subcontratista sujeto de un encausamiento civil o penal, conforme a la Sección 1001 del Título 18 y a la Sección 231 del Título 31 del Código de los Estados Unidos.

700
(iii) El contratista o el subcontratista pondrán los registros que exige el subinciso A.3.(i) a disposición de los representantes del HUD o de su delegado, o del Departamento del Trabajo, para su inspección, fotocopiado o transcripción, y permitirán que dichos representantes entrevisten a los empleados durante el horario hábil en el trabajo. Si el contratista o el subcontratista no entregan los registros necesarios o no los ponen a su disposición, el HUD o su delegado pueden, después de dar aviso por escrito al contratista, promotor, solicitante o propietario, tomar las medidas que sean necesarias para suscitar la suspensión de cualquier otro pago, adelanto o promesa de fondos adicionales. Además, no entregar los registros necesarios al solicitarseles o para ponerlos a su disposición puede ser motivo de inhabilitación, de conformidad con la sección 5.12 del 29 del CFR.

4. Aprendices y trabajadores en capacitación.

Um
(i) **Aprendices.** A los aprendices se les permitirá trabajar a menos de la tasa predeterminada para la labor que realizaron cuando se les emplee de conformidad con, y se les registre individualmente en, un programa de aprendices registrado ante la Oficina de Servicios Patronales, Laborales y de Capacitación para Aprendices de la Administración de Empleo y Capacitación del Departamento del Trabajo de los Estados Unidos, o ante una Agencia Estatal de Aprendizaje reconocida por la Oficina, o si una persona es empleada dentro de sus primeros 90 días de trabajo a prueba como aprendiz en un programa de aprendices tal y no está registrada de forma individual en el programa, pero recibió la certificación de la Oficina o de una Agencia de Aprendizaje Estatal (cuando corresponda) como admisible para trabajar a prueba en calidad de aprendiz. La relación permitida de aprendices a jornaleros en el sitio de la obra dentro de cualquier clasificación de oficios no deberá sobrepasar la permitida al contratista para toda la plantilla, conforme al programa registrado. Cualquier trabajador incluido en una nómina con una tasa salarial de aprendiz que no esté registrado o de otro modo empleado como se indicó anteriormente, recibirá como pago no menos que la tasa salarial correspondiente de la determinación salarial para la

clasificación del trabajo de hecho realizado. Además, a cualquier aprendiz que trabaje en el sitio de la obra excediendo la proporción permitida por el programa registrado se le pagará no menos que la tasa salarial correspondiente de la determinación salarial para el trabajo de hecho realizado. Cuando un contratista está construyendo para un proyecto en una localidad que no sea aquella en la que su programa esté registrado, habrán de observarse las proporciones y las tasas salariales (expresadas en porcentajes del salario por hora del jornalero) especificadas en el programa del contratista o subcontratista. A cada aprendiz deberá pagársele no menos que la tasa especificada en el programa registrado para su nivel de progreso, expresada como un porcentaje del salario por hora del jornalero especificada en la determinación salarial correspondiente. A los aprendices se les pagarán las prestaciones laborales marginales de acuerdo con las disposiciones del programa de aprendices. Si el programa de aprendices no especifica las prestaciones laborales marginales, a los aprendices se les debe pagar el monto total de los mismos que se indica en la determinación salarial para la clasificación correspondiente. Si el Administrador determina que impera una práctica diferente para la clasificación de aprendiz pertinente, las prestaciones se pagarán de acuerdo con dicha determinación. En caso de que la Oficina de Servicios Patronales, Laborales y de Capacitación para Aprendices o una Agencia Estatal de Aprendizaje reconocida por ella se retracte de la aprobación de un programa de aprendices, al contratista ya no se le permitirá utilizar aprendices a menos de la tasa predeterminada correspondiente para la labor realizada, hasta que se apruebe un programa aceptable

(ii) **Trabajadores en capacitación.** A excepción de lo dispuesto en la sección 5.16 del 29 del CFR, a los trabajadores en capacitación no se les permitirá laborar a menos que la tasa predeterminada para el trabajo realizado, a menos que se les emplee de conformidad con, y se les registre individualmente en, un programa que haya recibido una aprobación previa, según se demuestre mediante la certificación formal de la Administración de Empleo y Capacitación del Departamento del Trabajo de los Estados Unidos. La proporción de trabajadores en capacitación a jornaleros en el sitio de la obra no será mayor que la permitida por el plan aprobado por la Administración de Empleo y Capacitación. A cada trabajador en capacitación debe pagársele a no menos de la tasa especificada en el programa aprobado para su nivel de progreso, expresado como un porcentaje del salario por hora del jornalero especificada en la determinación salarial correspondiente. A los trabajadores en capacitación se les pagarán prestaciones laborales marginales de acuerdo con las disposiciones del programa de trabajadores en capacitación. Si el programa de trabajadores en capacitación no menciona prestaciones laborales marginales, a los trabajadores en capacitación se les pagará el monto total de los mismos que se indica en la determinación salarial, a menos que el administrador de la Sección de Salarios y Horarios Laborales determine que existe un programa de aprendices relacionado con el salario correspondiente para los jornaleros en la determinación salarial, que contemple menos que las prestaciones laborales marginales completas para los aprendices. A todo empleado listado en la nómina con un salario de aprendiz que no esté registrado y participando en un plan de capacitación aprobado por la Administración de Empleo y Capacitación se le pagará no menos que la tasa salarial correspondiente de la determinación salarial para el trabajo de hecho realizado. Además, a

excediendo la proporción permitida por el programa registrado se le pagará no menos que la tasa salarial correspondiente de la determinación salarial para el trabajo de hecho realizado. En caso de que la Administración de Empleo y Capacitación se retracte de la aprobación de un programa de capacitación, al contratista ya no se le permitirá utilizar trabajadores en capacitación a menos de la tasa predeterminada correspondiente para la labor realizada, hasta que se apruebe un programa aceptable.

(iii) **Igualdad de oportunidades en el empleo.** La utilización de aprendices, trabajadores en capacitación y jornaleros, según la Parte 5 del 29 del CFR, se conformará a los requisitos de igualdad de oportunidades en el empleo de la Orden Ejecutiva 11246 y sus enmiendas, y la Parte 30 del 29 del CFR.

5. Cumplimiento de los requisitos de la ley Copeland. El contratista deberá cumplir con los requisitos de la Parte 3 el 29 del CFR que se incorporan, por referencia, en este contrato.

6. Subcontratistas. El contratista o subcontratista insertará en todo subcontrato las cláusulas contenidas en los subincisos 1 al 11 de este inciso A y otras cláusulas tales que el HUD o su delegado pudieran exigir mediante las instrucciones debidas, así como una copia de la decisión sobre el salario vigente correspondiente, además de una cláusula exigiendo que los subcontratistas incluyan estas en cualquier subcontratos de nivel inferior. El contratista principal será responsable de que cualquier subcontratista o subcontratista de nivel inferior acate todas las cláusulas contractuales de este inciso.

7. Rescisión del contrato; inhabilitación. El incumplimiento de las cláusulas contractuales que constan en la sección 5.5 del 29 del CFR puede ser motivo de rescisión del contrato e inhabilitación como contratista y subcontratista, según lo dispuesto en la sección 5.12 del 29 del CFR.

8. Cumplimiento de los requisitos de la ley Davis-Bacon y otros relacionados. Todo fallo e interpretación de la ley Davis-Bacon y otras afines contenido en las Partes 1, 3 y 5 del 29 del CFR se incorporan aquí, por referencia, en este contrato.

9. Disputas sobre normas laborales. Las disputas que surjan de las disposiciones sobre normas laborales que establece este contrato no estarán sujetas a su cláusula sobre disputas generales. Tales disputas se resolverán de acuerdo con los procedimientos del Departamento del Trabajo que se establecen en las Partes 5, 6 y 7 del 29 del CFR. Las disputas, en el sentido de esta cláusula, incluyen aquellas surgidas entre el contratista (o cualquiera de sus subcontratistas) y el HUD o su delegado, el Departamento del Trabajo de los Estados Unidos, o los empleados o sus representantes.

10. (i) Certificación de la elegibilidad. Al suscribir este contrato, el contratista certifica que ni la suya (ni él o ella) ni ninguna persona o empresa que tenga un interés en su empresa es una persona o empresa inadmisibles para recibir contratos del gobierno en virtud de la Sección 3(a) de la ley Davis-Bacon o de la sección 5.12(a)(1) del 29 del CFR, o para recibir contratos del HUD o participar en sus programas, de conformidad con la Parte 24 del 24 del CFR.

(ii) Ninguna parte de este contrato se subcontratará a persona o firma inadmisibles alguna para recibir un contrato de gobierno en virtud de la Sección 3(a) de la ley de Davis-Bacon o de la sección 5.12(a)(1) del 29 del CFR, o para recibir contratos del HUD o participar en sus programas, de conformidad con la Parte 24 del 24 del CFR.

(iii) La sanción por hacer declaraciones falsas está prescrita en el Código Penal de los Estados Unidos, sección 1001 del 18 del Código de los Estados Unidos (U.S.C., por sus siglas en inglés). Además, el Código Penal de los Estados Unidos, en la Sección 1 01 0 del Título 18 del U.S.C., "Transacciones de la Administración Federal de Vivienda", establece, en parte, que: "Quienquiera que, con el propósito de... influir en modo alguno en la actuación de dicha administración... haga, profiera o publique una declaración sabiendo que es falsa... será multado por no más de \$5,000 o encarcelado por no más de dos años, o ambas cosas".

11. Reclamaciones, acciones judiciales o testimonios de los empleados. Ningún obrero o mecánico para quien corresponda el sueldo, salario u otras disposiciones laborales de este contrato será despedido ni de ningún otro modo discriminado por el contratista o por subcontratista alguno por haber presentado una queja, o entablado o hecho que se entable algún proceso judicial, ni por haber testificado, o estar por hacerlo, testificar en algún proceso judicial al amparo de, o en relación con las normas laborales correspondientes en virtud de este contrato para su empleador.

B. Ley de Horas de Trabajo y Normas de Seguridad Contractuales. Las disposiciones del presente inciso B corresponden cuando el monto del contrato principal pasa de \$100,000. Del modo que se usan en este inciso, los términos "obreros" y "mecánicos" incluyen a vigilantes y guardias de seguridad.

(1) **Requisitos de horas extra.** Ningún contratista o subcontratista contratado para realizar parte alguna del trabajo del contrato que pudiera necesitar o implicar el empleo de obreros o mecánicos exigirá ni permitirá que un trabajador o mecánico tal, en cualquier semana laboral en la que se emplee al individuo para realizar dicho trabajo, labore más de 40 horas en esa semana laboral, a menos que dicho trabajador o mecánico sea compensado a una tasa no menor que una y media veces el salario básico por todas las horas trabajadas después de las 40 horas en esa semana laboral.

(2) **Contravención; responsabilidad por salarios impagos; liquidación de daños y perjuicios.** En caso de cometerse alguna contravención a la cláusula establecida en el subinciso (1) de este apartado, el contratista y cualquier subcontratista responsable deberán responder por los salarios impagos. Además, dicho contratista y subcontratista serán responsables ante los Estados Unidos (en el caso de trabajo realizado en virtud de un contrato para el Distrito de Columbia o un territorio de dicho Distrito, o para dicho territorio) de la liquidación de daños y perjuicios. Tal liquidación de daños y perjuicios se calculará con respecto a cada obrero o mecánico individual, incluidos los vigilantes y guardias de seguridad, empleado en contravención de la cláusula establecida en el subinciso (1) de este apartado, por la suma de \$10 por cada día natural en el que dicho individuo se le haya exigido o permitido trabajar más de la semana laboral normal de 40 horas sin el pago de horas extra que exige la cláusula establecida en el subinciso (1) de este apartado.

(3) Retención de salarios impagos, y para la liquidación de daños y perjuicios. El HUD o su delegado, a su propio recurso o al solicitario por escrito un representante autorizado del Departamento del Trabajo, retendrán o verán que se retenga, de cualquier dinero pagadero por el trabajo realizado por el contratista o por el subcontratista en virtud de cualquier contrato tal o de cualquier otro de carácter federal que se tenga con el mismo contrato principal, o de cualquier otro contrato que reciba asistencia federal supeditada a la ley de Horas de Trabajo y Normas de Seguridad Contractuales y que tenga el mismo contratista principal, las sumas que se determinen como necesarias para saldar cualquier responsabilidad de dicho contratista o subcontratista por concepto de salarios impagos y liquidación de daños y perjuicios, según lo dispuesto en la cláusula establecida en el subinciso (2) de este apartado.

(4) Subcontratos. El contratista o subcontratista insertará en todo subcontrato las cláusulas establecidas en los subincisos (1) al (4) de este apartado, y también una cláusula exigiendo que los subcontratistas incluyan estas en cualquier subcontrato de nivel inferior. El contratista principal será responsable de que cualquier subcontratista o subcontratista de nivel inferior acate todas las cláusulas establecidas en los subincisos (1) al (4) de este apartado.

C. Salud y seguridad. Las disposiciones del presente inciso C corresponden cuando el monto del contrato principal pasa de \$100,000.

(1) Ningún obrero o mecánico tendrá que trabajar en los alrededores ni en condiciones laborales que sean insalubres, riesgosas o peligrosas para su salud y seguridad, según se determine conforme a las normas de seguridad y salud para la construcción promulgadas por el Secretario de Trabajo por reglamento.

(2) El Contratista acatará toda reglamentación dictada por el Secretario de Trabajo, de conformidad con la Parte 1926 del Título 29, y no hacerlo puede acarrear la imposición de sanciones, de conformidad con la ley de Horas de Trabajo y Normas de Seguridad Contractuales (ley pública 91-54, sección 96 del 83 de la Legislación Compilada de los Estados Unidos). Sección 3701 del 40 del U.S.C., y las siguientes.

(3) El contratista incluirá las disposiciones de este inciso en cada subcontrato, de modo que serán vinculantes para cada subcontratista. El contratista tomará tales medidas con respecto a cualquier subcontratista que el Secretario de Vivienda y Desarrollo Urbano o el Secretario del Trabajo ordenen como una forma de hacer cumplir tales disposiciones.

ATTACHMENT K

"General Decision Number: PR20210003 01/01/2021

Superseded General Decision Number: PR20200003

State: Puerto Rico

Construction Type: Residential

Counties: Puerto Rico Statewide.

RESIDENTIAL CONSTRUCTION PROJECTS (consisting of single family homes and apartments up to and including 4 stories)

Note: Under Executive Order (EO) 13658, an hourly minimum wage of \$10.95 for calendar year 2021 applies to all contracts subject to the Davis-Bacon Act for which the contract is awarded (and any solicitation was issued) on or after January 1, 2015. If this contract is covered by the EO, the contractor must pay all workers in any classification listed on this wage determination at least \$10.95 per hour (or the applicable wage rate listed on this wage determination, if it is higher) for all hours spent performing on the contract in calendar year 2021. If this contract is covered by the EO and a classification considered necessary for performance of work on the contract does not appear on this wage determination, the contractor must pay workers in that classification at least the wage rate determined through the conformance process set forth in 29 CFR 5.5(a)(1)(ii) (or the EO minimum wage rate, if it is higher than the conformed wage rate). The EO minimum wage rate will be adjusted annually. Please note that this EO applies to the above-mentioned types of contracts entered into by the federal government that are subject to the Davis-Bacon Act itself, but it does not apply to contracts subject only to the Davis-Bacon Related Acts, including those set forth at 29 CFR 5.1(a)(2)-(60). Additional information on contractor requirements and worker protections under the EO is available at www.dol.gov/whd/govcontracts.

76

W

Modification Number Publication Date
0 01/01/2021

* SUPR1993-002 10/29/1993

	Rates	Fringes
CARPENTER.....	\$ 7.25	.65
CEMENT MASON/CONCRETE FINISHER...	\$ 7.25	
ELECTRICIAN.....	\$ 7.25	.64
IRONWORKER.....	\$ 7.25	.63
Laborer, Unskilled.....	\$ 7.25	.36
PAINTER.....	\$ 7.25	

PLUMBER.....	\$ 7.25	.56
Power equipment operators:		
Cranes.....	\$ 7.25	1.14
Diggers.....	\$ 7.25	
TRUCK DRIVER.....	\$ 7.25	

WELDERS - Receive rate prescribed for craft performing operation to which welding is incidental.

Note: Executive Order (EO) 13706, Establishing Paid Sick Leave for Federal Contractors applies to all contracts subject to the Davis-Bacon Act for which the contract is awarded (and any solicitation was issued) on or after January 1, 2017. If this contract is covered by the EO, the contractor must provide employees with 1 hour of paid sick leave for every 30 hours they work, up to 56 hours of paid sick leave each year. Employees must be permitted to use paid sick leave for their own illness, injury or other health-related needs, including preventive care; to assist a family member (or person who is like family to the employee) who is ill, injured, or has other health-related needs, including preventive care; or for reasons resulting from, or to assist a family member (or person who is like family to the employee) who is a victim of, domestic violence, sexual assault, or stalking. Additional information on contractor requirements and worker protections under the EO is available at www.dol.gov/whd/govcontracts.

Unlisted classifications needed for work not included within the scope of the classifications listed may be added after award only as provided in the labor standards contract clauses (29CFR 5.5 (a) (1) (ii)).

The body of each wage determination lists the classification and wage rates that have been found to be prevailing for the cited type(s) of construction in the area covered by the wage determination. The classifications are listed in alphabetical order of "identifiers" that indicate whether the particular rate is a union rate (current union negotiated rate for local), a survey rate (weighted average rate) or a union average rate (weighted union average rate).

Union Rate Identifiers

A four letter classification abbreviation identifier enclosed in dotted lines beginning with characters other than "SU" or "UAVG" denotes that the union classification and rate were prevailing for that classification in the survey. Example: PLUM0198-005 07/01/2014. PLUM is an abbreviation identifier of the union which prevailed in the survey for this classification, which in this example would be Plumbers. 0198 indicates the local union number or district council number where applicable, i.e., Plumbers Local 0198. The next number, 005 in the example, is an internal number used in processing the wage determination. 07/01/2014 is the effective date of the most current negotiated rate, which in this example is July 1,

2014.

Union prevailing wage rates are updated to reflect all rate changes in the collective bargaining agreement (CBA) governing this classification and rate.

Survey Rate Identifiers

Classifications listed under the "SU" identifier indicate that no one rate prevailed for this classification in the survey and the published rate is derived by computing a weighted average rate based on all the rates reported in the survey for that classification. As this weighted average rate includes all rates reported in the survey, it may include both union and non-union rates. Example: SULA2012-007 5/13/2014. SU indicates the rates are survey rates based on a weighted average calculation of rates and are not majority rates. LA indicates the State of Louisiana. 2012 is the year of survey on which these classifications and rates are based. The next number, 007 in the example, is an internal number used in producing the wage determination. 5/13/2014 indicates the survey completion date for the classifications and rates under that identifier.

Survey wage rates are not updated and remain in effect until a new survey is conducted.

Union Average Rate Identifiers

700 Classification(s) listed under the UAVG identifier indicate that no single majority rate prevailed for those classifications; however, 100% of the data reported for the classifications was union data. EXAMPLE: UAVG-OH-0010 08/29/2014. UAVG indicates that the rate is a weighted union average rate. OH indicates the state. The next number, 0010 in the example, is an internal number used in producing the wage determination. 08/29/2014 indicates the survey completion date for the classifications and rates under that identifier.

A UAVG rate will be updated once a year, usually in January of each year, to reflect a weighted average of the current negotiated/CBA rate of the union locals from which the rate is based.

WAGE DETERMINATION APPEALS PROCESS

1.) Has there been an initial decision in the matter? This can be:

- * an existing published wage determination
- * a survey underlying a wage determination
- * a Wage and Hour Division letter setting forth a position on a wage determination matter
- * a conformance (additional classification and rate) ruling

On survey related matters, initial contact, including requests for summaries of surveys, should be with the Wage and Hour Regional Office for the area in which the survey was conducted because those Regional Offices have responsibility for the Davis-Bacon survey program. If the response from this initial contact is not satisfactory, then the process described in 2.) and 3.) should be followed.

With regard to any other matter not yet ripe for the formal process described here, initial contact should be with the Branch of Construction Wage Determinations. Write to:

Branch of Construction Wage Determinations
Wage and Hour Division
U.S. Department of Labor
200 Constitution Avenue, N.W.
Washington, DC 20210

2.) If the answer to the question in 1.) is yes, then an interested party (those affected by the action) can request review and reconsideration from the Wage and Hour Administrator (See 29 CFR Part 1.8 and 29 CFR Part 7). Write to:

Wage and Hour Administrator
U.S. Department of Labor
200 Constitution Avenue, N.W.
Washington, DC 20210

The request should be accompanied by a full statement of the interested party's position and by any information (wage payment data, project description, area practice material, etc.) that the requestor considers relevant to the issue.

76

3.) If the decision of the Administrator is not favorable, an interested party may appeal directly to the Administrative Review Board (formerly the Wage Appeals Board). Write to:

Administrative Review Board
U.S. Department of Labor
200 Constitution Avenue, N.W.
Washington, DC 20210

4.) All decisions by the Administrative Review Board are final.

=====

END OF GENERAL DECISION

"

W